

SYD4110

110cm "Symphony" Dual fuel 4 cavity Cooker
with 2 side opening oven doors & Gas hob, St/steel
Energy rating AA

EAN13: 8017709199227

MAIN OVEN - TOP RIGHT



- 7 functions Inc. Circulaire element with fan
- Oven capacity: gross - 68 litres, net - 61 litres

Side opening oven door

- Easy clean enamel interior
- Digital electronic clock/programmer
- Air cooling system
- Closed door grilling
- Triple glazed oven door

Vapor Clean function

AUXILIARY OVEN – LOWER LEFT



- 6 functions Inc. upper and lower element with fan
- Oven capacity: gross - 68 litres, net - 61 litres

Side opening oven door

- Easy clean enamel interior
- Air cooling system
- Closed door grilling

Vapor clean function

GRILL COMPARTMENT – TOP LEFT



- Oven capacity: gross - 41 litres, net - 36 litres
- Easy clean enamel interior
- Air cooling system
- Closed door grilling
- Fully variable grill – max grill power: 2.7kW
- Triple glazed removable door

STORAGE DRAWER- LOWER RIGHT:



GAS HOB

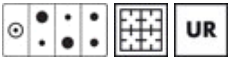

- 7 gas burners
- Front right: 1.80 kW
- Rear Right: 1.80 kW
- Front Center : 2.90 kW
- Rear Center : 1.00 kW
- Front Left: 1.00 kW
- Rear Left: 2.90 kW
- Left: Ultra rapid burner 4.20 kW
- Heavy duty cast iron pan stands & black burner caps
- Automatic electronic ignition
- Safety valves
- Adaptable for LPG

Nominal power: 8.4 kW

- Supply can vary depending on usage, please consult a qualified electrician for ampere requirement

STANDARD ACCESSORIES:

Main oven & Auxiliary oven:

- 2 x Sets of partial extractable telescopic guides
- 2 x Extra deep tray (40mm deep)
- 2 x Grill mesh
- 4 x Chrome shelves

Grill compartment :

- 1 x Extra deep tray (40mm deep)
- 1 x Chrome shelf

Hob:

- 1 x Wok support

NB: This model supersedes the SY4110-8

Functions

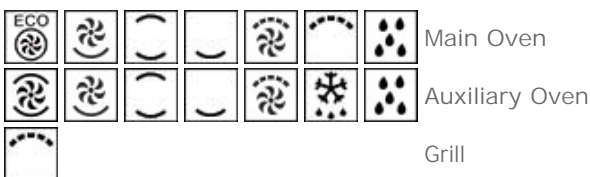

Versions

- **SYD4110** - 110cm Symphony 4 cavity range cooker with side opening doors, St Steel
- **SYD4110BL** - 110cm Symphony 4 cavity range cooker with side opening doors, Gloss Black

Smeg (UK) Ltd
The Magna Building, Wyndyke Furlong, Abingdon
OX14 1DZ
Tel. +44 (0)844 557 9907
Fax +44 (0)844 557 9337

Main Oven

Eco Circulaire:
 Some models have Eco Circulaire in place of Circulaire but the 2 functions work in the same way. This is the most energy efficient standard oven function for the cooker.



FAN WITH LOWER ELEMENT/ CIRCOGAS:

In electric ovens this combination completes cooking more quickly of foods that are ready on the surface, but that require more cooking inside, without further browning. In gas ovens the fan distributes the heat quickly and evenly throughout the oven cavity, avoiding flavour transfer when cooking a number of different dishes at the same time.



Upper and lower element only:

A traditional cooking method best suited for single items located in the centre of the oven. The top of the oven will always be hottest. Ideal for roast, fruit cakes, bread etc.



Lower heating element only:

Ideal for foods that require extra base temperature without browning, e.g. pastry dishes, pizza. Also suitable for slow cooking of stews and casseroles.



Fan with grill element:

The fan reduces the fierce heat from the grill, providing an excellent method of grilling various foods, chops, steaks, sausages etc. giving even browning and heat distribution, without drying out the food. The top two levels recommended for use, and the lower part of the oven can be used to keep items warm at the same time, an excellent facility when cooking a grilled breakfast. Half grill (centre portion only) is ideal for small quantities of food.



Grill element:

For rapid cooking and browning of foods. Best results can be obtained by using the top shelf for small items, the lower shelves for larger ones, such as chops or sausages. For half grill heat is generated only at the centre of the element, so is ideal for smaller quantities.

Vapor clean
 Vapor clean

Auxiliary Oven

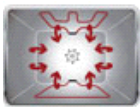

Fan with upper and lower elements:

The elements combined with the fan aim to provide more uniform heat, a similar method to conventional cooking, so pre-heat is required. Most suitable for items requiring slow cooking methods.



FAN WITH LOWER ELEMENT/ CIRCOGAS:

In electric ovens this combination completes cooking more quickly of foods that are ready on the surface, but that require more cooking inside, without further browning. In gas ovens the fan distributes the heat quickly and evenly throughout the oven cavity, avoiding flavour transfer when cooking a number of different dishes at the same time.

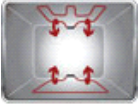
**Upper and lower element only:**

A traditional cooking method best suited for single items located in the centre of the oven. The top of the oven will always be hottest. Ideal for roast, fruit cakes, bread etc.

**Lower heating element only:**

Ideal for foods that require extra base temperature without browning, e.g. pastry dishes, pizza. Also suitable for slow cooking of stews and casseroles.

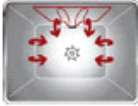
**Fan with grill element:**

The fan reduces the fierce heat from the grill, providing an excellent method of grilling various foods, chops, steaks, sausages etc. giving even browning and heat distribution, without drying out the food. The top two levels recommended for use, and the lower part of the oven can be used to keep items warm at the same time, an excellent facility when cooking a grilled breakfast. Half grill (centre portion only) is ideal for small quantities of food.

**Snowflake:**

With the switch on this symbol, no heating is possible even if the thermostat is turned.



Vapor clean
Vapor clean

Grill

**Grill element:**

For rapid cooking and browning of foods. Best results can be obtained by using the top shelf for small items, the lower shelves for larger ones, such as chops or sausages. For half grill heat is generated only at the centre of the element, so is ideal for smaller quantities.



SYD4110

Symphony
110 cm
stainless steel
hob type: cookers with gas hob
oven type: electric
energy rating A+A

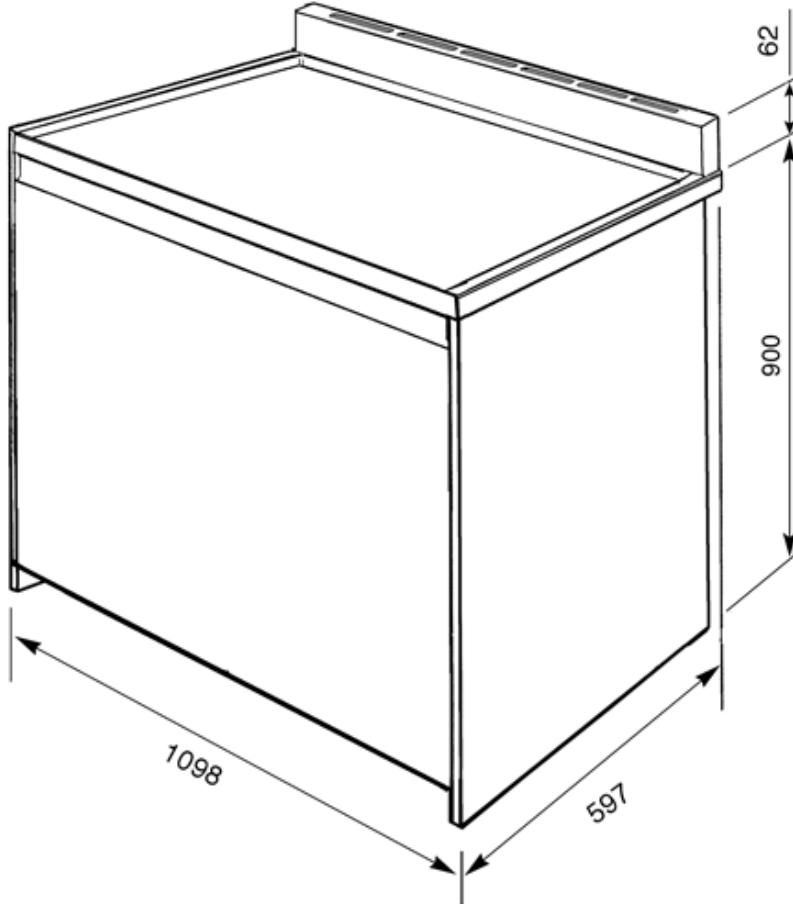

Smeg (UK) Ltd
The Magna Building, Wyndyke Furlong, Abingdon
OX14 1DZ
Tel. +44 (0)844 557 9907
Fax +44 (0)844 557 9337