



Operating and installation instructions



Ovens





To avoid the risk of accidents or damage to the appliance it is **essential** to read these instructions before it is installed and used for the first time.

Contents

Warning and Safety instructions	7
Caring for the environment	17
Oven overview	18
Oven controls	19
On/Off sensor ①	20
Function selector	20
Display.....	21
Rotary selector < >	21
Sensor controls	22
Features	24
Model numbers	24
Data plate	24
Items supplied	24
Accessories supplied and available to order.....	24
Side runners	25
Baking tray, universal tray and rack with non-tip notches	25
FlexiClip telescopic runners HFC 72	26
Oven controls	30
Safety features	30
System lock 	30
Cooling fan	30
Vented oven door	30
Door lock - Pyrolytic cleaning	30
PerfectClean treated surfaces	31
Pyrolytic accessories.....	31
Before using for the first time	32
Before using for the first time	32
Setting the time of day for the first time.....	32
Heating up the oven for the first time and rinsing the steam injection system	33
Settings	36
Altering the time of day	36
Changing factory default settings	37
System lock 	40
Minute minder 	42
To set the minute minder.....	42
To change the duration	43
To cancel the time set for the minute minder	43

Overview of functions	44
Tips on saving energy	46
Using the oven	48
Simple operation	48
Cooling fan	48
To alter the temperature	49
Temperature indicator light.....	49
Pre-heating the oven	50
Switching on and off automatically	51
Setting the cooking duration	51
Setting a cooking duration and finish time.....	52
At the end of the cooking duration.....	53
Changing the cooking duration	53
Deleting a cooking duration	54
Deleting a finish time	54
Moisture plus 	55
Moisture plus function 	56
Injecting bursts of steam	58
Automatic burst of steam.....	58
Injecting bursts of steam manually.....	58
Residual water evaporation.....	59
To start residual water evaporation immediately.....	60
To cancel the residual water evaporation process	61
Baking	62
Notes on using the baking charts	63
Baking charts	64
Creamed mixture.....	64
Rubbed in mixture	66
Yeast mixtures and quark dough.....	68
Sponge mix	70
Choux pastry, puff pastry, meringue.....	71
Roasting	72
Notes on using the roasting charts	73
Roasting charts	74
Beef, veal.....	74
Pork	75
Lamb, game	76
Poultry, fish.....	77

Contents

Low temperature cooking	78
Grilling	80
Notes on the grilling chart	82
Grilling chart	83
Special applications	84
Defrost	84
Drying food	85
Gentle bake	86
Frozen food/Ready meals	87
Heat crockery	88
Cleaning and care	89
Unsuitable cleaning agents	89
Tips	90
Normal soiling	90
Stubborn soiling (excluding the FlexiClip runners)	91
Pyrolytic cleaning  of the oven interior	92
Setting up for pyrolytic cleaning	92
Starting Pyrolytic cleaning	93
At the end of pyrolytic cleaning	94
If pyrolytic cleaning is cancelled	95
Removing the door	96
Dismantling the door	97
Refitting the door	101
Removing the side runners with FlexiClip runners	102
Lowering the top heat/grill element	103
Descaling the steam injection system 	104
Sequence of a descaling cycle	104
Preparation	105
Carrying out the descaling process	106
Problem solving guide	109
Service	114
Contact in case of malfunction	114
Warranty	114
Electrical connection	115
Oven	115
Electrical connection: Other countries	116

Building-in diagrams	117
Appliance and niche dimensions	117
Installation in a base unit.....	117
Installation in a tall unit.....	118
Front dimensions	119
Installing the oven	120
Recipes	121
Bake-off products	122
White bread	124
Flat bread	125
Herb bread	126
Olive bread	127
Sesame cheese rolls	128
Rye bread	129
Mixed grain bread.....	130
Multigrain bread	131
Yeast rolls	132
Seeded rolls.....	133
Italian Mozzarella bread.....	134
Sunday rolls.....	135
Buttermilk bread	136
Chocolate breakfast rolls.....	137
Onion flat bread.....	138
Quark rolls	139
Buttermilk loaf	140
Malted pumpkin seed rolls	141
Yeast dough men	142
Yeast pretzels	143
Bacon or herb baguettes.....	144
Ham and cheese rolls.....	145
Apricot loaf	146
Butter cake	147
Pine nut and almond cake.....	148
Plaited walnut loaf	149
Cinnamon and macadamia ring	150
Sea bream in a herb sauce.....	151
Savoy cabbage and salmon gratin.....	152
Stuffed salmon trout.....	153
Pollock, Viennese style.....	154
Salmon and spinach pasta bake.....	155
Salmon fillet in a Muscadet sauce	156

Contents

Pollock delicioso	157
Trout stuffed with mushrooms.....	158
Pikeperch with herbs.....	159
Sweet and sour chicken	160
Herby chicken fillets	161
Marinated chicken thighs	162
Turkey roulade with a spinach ricotta filling	163
Turkey thighs	164
Fillet of beef in a Port sauce	165
Braised beef roulades	166
Braised silverside of veal.....	168
Glazed gammon	169
Stuffed pork tenderloin.....	170
Pork casserole with apples	171
Spare ribs	172
Spanish garlic rabbit.....	173
Saddle of roebuck	174
Lamb in a thyme and mustard sauce	176
Potato dumplings	177
Cheese soufflés.....	178
Spring pie	179
Cheese pie	180
Tortellini, ham and rocket bake	181
Mushroom cannelloni	182
Potato cheese bake.....	183
Lasagne.....	184
Dumplings with plum compote	186
Sweet cherry soufflé.....	187
Note for test institutes	188
Test food acc. to EN 60350-1	188
Energy efficiency class	189
Data sheets for household ovens.....	189

Warning and Safety instructions

This appliance complies with statutory safety requirements. Inappropriate use can, however, lead to personal injury and damage to property.

To avoid the risk of accidents and damage to the appliance, please read these instructions carefully before using it for the first time. They contain important notes on installation, safety, use and maintenance.

Miele cannot be held liable for damage or injury caused by non-compliance with these instructions.

Keep these instructions in a safe place and ensure that new users are familiar with the contents. Pass them on to any future owner.

Warning and Safety instructions

Correct application

- ▶ This oven is intended for use in domestic households and similar working and residential environments.
- ▶ The oven is not intended for outdoor use.
- ▶ This oven is intended for domestic use only to cook food, and in particular to bake, roast, grill, cook, defrost and dry food. Any other use is not supported by the manufacturer and could be dangerous.
- ▶ People with reduced physical, sensory or mental capabilities, or lack of experience or knowledge who are not able to use the appliance safely on their own must be supervised whilst using it. They may only use it unsupervised if they have been shown how to use it safely and recognise and understand the consequences of incorrect operation.
- ▶ This oven is supplied with a special lamp to cope with particular conditions (e.g. temperature, moisture, chemical resistance, abrasion resistance and vibration). This special lamp must only be used for the purpose it is intended for. It is not suitable for room lighting.

Safety with children

- ▶ Children under 8 years of age must be kept away from the appliance unless they are constantly supervised.
- ▶ Children 8 years and older may only use the oven unsupervised if they have been shown how to use it safely and recognise and understand the consequences of incorrect operation.
- ▶ Children must not be allowed to clean or maintain the appliance unsupervised.
- ▶ Please supervise children in the vicinity of the oven and do not let them play with it.
- ▶ Danger of suffocation. Packaging, e.g. plastic wrappings, must be kept out of the reach of babies and children. Whilst playing, children could become entangled in packaging or pull it over their head and suffocate.
- ▶ Danger of burning. Children's skin is far more sensitive to high temperatures than that of adults. External parts of the oven such as the door glass, control panel and the vents become quite hot during use. Do not let children touch the oven whilst it is in use.
- ▶ Danger of burning.
Children's skin is far more sensitive to high temperatures than that of adults. The oven gets hotter during pyrolytic cleaning than it does in normal use. Do not let children touch the oven whilst the Pyrolytic cleaning programme is running.
- ▶ Danger of injury. The door can support a maximum weight of 15 kg.
Do not let children sit on the door, lean against it or swing on it. They could injure themselves.

Warning and Safety instructions

Technical safety

- ▶ Unauthorised installation, maintenance and repairs can cause considerable danger for the user. Installation, maintenance and repairs must only be carried out by a Miele authorised technician.
- ▶ Never use a damaged oven. It could be dangerous. Check it for visible signs of damage before using it.
- ▶ Reliable and safe operation of this oven can only be assured if it has been connected to the mains electricity supply.
- ▶ The electrical safety of this appliance can only be guaranteed when correctly earthed. It is essential that this standard safety requirement is met. If in any doubt please have the electrical installation tested by a qualified electrician.
- ▶ To avoid the risk of damage to the oven, make sure that the connection data on the data plate (voltage and frequency) match the mains electricity supply before connecting the oven to the mains. Consult a qualified electrician if in doubt.
- ▶ Do not connect the appliance to the mains electricity supply by a multi-socket unit or an extension lead. These do not guarantee the required safety of the appliance (fire hazard).
- ▶ For safety reasons, this appliance may only be used after it has been built in.
- ▶ The oven must not be used in a non-stationary location (e.g. on a ship).
- ▶ While the appliance is under warranty, repairs should only be undertaken by a Miele authorised service technician. Otherwise the warranty is invalidated.
- ▶ Tampering with electrical connections or components and mechanical parts is highly dangerous to the user and can cause operational faults.
Never open the casing of the appliance.

Warning and Safety instructions

- ▶ Miele can only guarantee the safety of the appliance when genuine original Miele replacement parts are used. Faulty components must only be replaced by Miele spare parts.
- ▶ If the connection cable is damaged or if the oven is supplied without a cable, it must be replaced or fitted with a special connection cable by a Miele authorised technician (see “Electrical connection”).
- ▶ During installation, maintenance and repair work, the appliance must be disconnected from the mains electricity supply, e.g. if the oven lighting is faulty (see “Problem solving guide” and “Electrical connection”).
- ▶ In order to function correctly, the oven requires an adequate supply of cool air. Ensure that the supply of cool air is not impaired (e.g. by heat insulation strips in the housing unit). Please also ensure that the cool air supply is not unduly heated by other heat sources such as a solid fuel stove.
- ▶ If the oven is installed behind a furniture panel (e.g. a door), ensure that the door is never closed whilst the oven is in use. Heat and moisture can build up behind a closed furniture panel and cause subsequent damage to the oven, the housing unit and the floor. Do not close the door until the oven has cooled down completely.

Warning and Safety instructions

Correct use



Danger of burning.

The oven becomes hot when in use.

You could burn yourself on the heating elements, oven interior, cooked food or oven accessories.

Wear oven gloves when placing food in the oven, turning or removing it and when adjusting oven shelves etc. in a hot oven.

▶ Due to the high temperatures radiated, objects left near the oven when it is in use could catch fire.

Do not use the oven to heat up the room.



▶ Oil and fat can ignite if overheated. Never leave the oven unattended when cooking with oil and fat.

If it does ignite do not put the flames out with water. Switch the oven off immediately and then suffocate the flames by keeping the oven door closed.

▶ Grilling food for an excessively long time can cause it to dry out with the risk of catching fire.

Do not exceed recommended grilling times.

▶ Some types of food dry out quickly and can self-ignite if high grill temperatures are used.

Never use the grill to finish baking part-cooked rolls or bread or to dry flowers or herbs. Use Fan plus  or Conventional heat  for this type of procedure.

▶ If using alcohol in your recipes, please be aware that high temperatures can cause the alcohol to vaporise. The vapour can catch fire on hot heating elements.

▶ Food which is stored in the oven or left in it to be kept warm can dry out and the moisture released can lead to corrosion damage in the oven.

Always cover food that is left in the oven to keep warm.



Warning and Safety instructions

▶ When using residual heat to keep food in the oven warm, the high moisture content and amount of condensation in the oven can cause corrosion damage. The control panel, the worktop or the housing unit can also suffer damage.

When using residual heat do not switch the oven off. Instead set the temperature to the lowest setting and leave the oven on the selected function. The fan will then remain on automatically and dissipate the moisture.

▶ A build-up of heat can cause the enamel on the floor of the oven to crack or shatter.

Do not line the floor of the oven with anything, e.g. aluminium foil or oven liners.

If you wish to place dishes on the floor of the oven during cooking, or place crockery on the floor of the oven to heat it up, you can do so, but only with the Fan plus  or Gentle bake  function.

▶ The enamelling on the oven floor can become damaged by items being pushed around on it.

If using the oven to store pots and pans, ensure that you avoid pushing them around on the oven floor.

▶ If cold liquid is poured onto a hot surface steam will occur, which can cause scalding. The sudden change in temperature can also damage enamel surfaces.

Do not pour cold liquid directly onto hot enamelled surfaces.

▶ During cooking processes using moisture and during the residual moisture evaporation process steam is produced which can cause serious injury by scalding. Do not open the door whilst a burst of steam is being released or during the evaporation process.

▶ It is important that the temperature in the food being cooked is evenly distributed and sufficiently high. Stir and / or turn it to ensure even heat distribution.

Warning and Safety instructions

- ▶ Plastic containers which are not suitable for use in an oven can melt at high temperatures and can even damage the oven or catch fire.
Only use plastic containers which are declared by the manufacturer as being suitable for use in an oven. Follow the manufacturer's instructions on use.
- ▶ Do not heat up food in closed containers e.g. tins or sealed jars in the oven, as pressure will build up in the container, causing it to explode.
- ▶ You could injure yourself on the open oven door or trip over it. Avoid leaving the door open unnecessarily.
- ▶ The door can support a maximum weight of 15 kg. Do not sit on or lean against an open door, and do not place heavy objects on it. Also make sure that nothing can get trapped between the door and the oven cavity. The oven could get damaged.

Stainless steel appliances

- ▶ Adhesives will damage the stainless steel surface and cause it to lose its dirt-repellent protective coating. Do not use sticky notes, transparent adhesive tape, masking tape or other types of adhesive on the stainless steel surface.
- ▶ The surface is susceptible to scratching. Even magnets can cause scratching.

Cleaning and care

- ▶ Do not use a steam cleaning appliance to clean this appliance. The steam could reach electrical components and cause a short circuit.
- ▶ Scratches on the door glass can result in the glass breaking. Do not use abrasive cleaners, hard sponges, brushes or sharp metal tools to clean the door glass.
- ▶ The side runners can be removed for cleaning (see “Cleaning and care”). Ensure that they are replaced correctly.
- ▶ Coarse soiling should be removed before running the Pyrolytic cleaning programme. If not removed, coarse soiling can smoke and cause the Pyrolytic cleaning programme to switch itself off.
- ▶ In areas which may be subject to infestation by cockroaches or other vermin, pay particular attention to keeping the appliance and its surroundings clean at all times. Any damage caused by cockroaches or other vermin will not be covered by the warranty.

Warning and Safety instructions

Accessories

- ▶ Only use genuine original Miele accessories and spare parts with this appliance. Using accessories or spare parts from other manufacturers will invalidate the warranty and Miele cannot accept liability.
- ▶ If you have a Miele HUB 5000-M, HUB 5001-M, HUB 5000-XL or a HUB 5001-XL oven dish, do not place it on Shelf level 1. This would damage the floor of the oven. The very small gap between the bottom of the dish and the oven floor would cause a build-up of heat and could cause the enamel to crack or chip. Never place a Miele oven dish on the top rail of Shelf level 1 as it will not be held securely in this position by the anti-tip notches on the runners. In general it is best to use Shelf level 2.
- ▶ The high temperatures used during pyrolytic cleaning will damage accessories that are not designed for cleaning in the Pyrolytic programme. Please remove these accessories from the oven interior before starting the Pyrolytic cleaning programme. This also applies to non-pyrolytic accessories purchased separately to the oven (see “Cleaning and care”).

Disposal of the packing material

The packaging is designed to protect the appliance from damage during transportation. The packaging materials used are selected from materials which are environmentally friendly for disposal and should be recycled.

Recycling the packaging reduces the use of raw materials in the manufacturing process and also reduces the amount of waste in landfill sites.

Disposing of your old appliance

Electrical and electronic appliances often contain valuable materials. They also contain specific materials, compounds and components, which were essential for their correct function and safety. These could be hazardous to human health and to the environment if disposed of with your domestic waste or if handled incorrectly. Please do not, therefore, dispose of your old appliance with your household waste.



Please dispose of it at your local community waste collection / recycling centre for electrical and electronic appliances, or contact your dealer or Miele for advice. You are also responsible (by law, depending on country) for deleting any personal data that may be stored on the appliance being disposed of. Please ensure that your old appliance poses no risk to children while being stored prior to disposal.

Oven overview

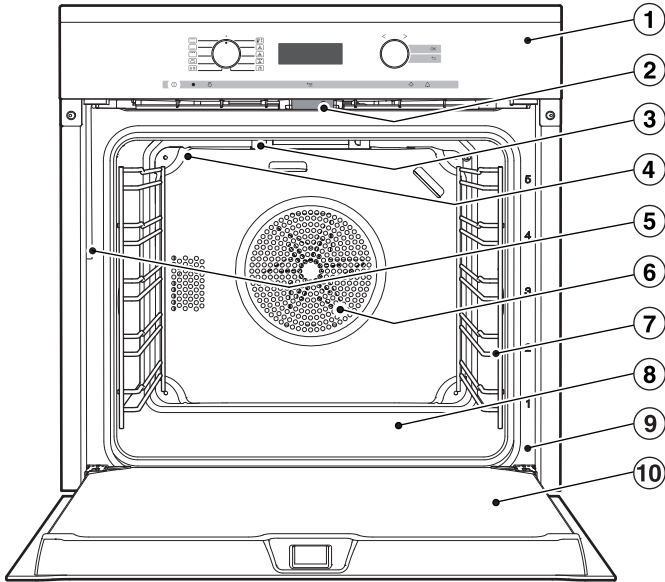

- ① Oven controls*
- ② Door lock - Pyrolytic cleaning
- ③ Top heat/grill element
- ④ Steam inlet openings
- ⑤ Water intake pipe for the steam injection system
- ⑥ Air inlet for the fan with ring heating element behind it
- ⑦ Side runners with 5 shelf levels
- ⑧ Oven floor with bottom heat element underneath it
- ⑨ Front frame with data plate
- ⑩ Door

* features will vary depending on model

Oven controls

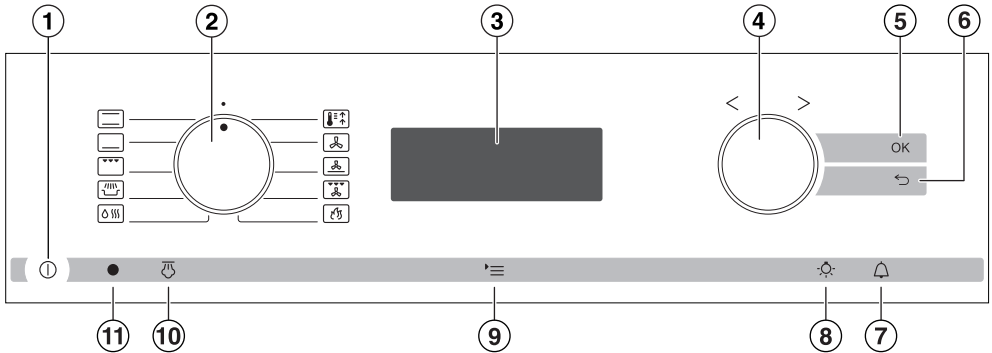

- ① Recessed On/Off sensor ①
For switching on and off
- ② Function selector
For selecting oven functions
- ③ Display
For displaying the time of day and settings
- ④ Rotary selector < >
For setting values
- ⑤ OK sensor
For confirming settings and instructions
- ⑥ ↶ sensor
For going back one step at a time
- ⑦ 🔔 sensor
For setting the minute minder
- ⑧ ⚡ sensor
For switching the oven interior lighting on and off
- ⑨ ≡ sensor
For calling up functions
- ⑩ 🌀 sensor
For injecting bursts of steam
- ⑪ Optical interface
(for Miele service technician use only)

Oven controls

On/Off sensor ①

The On/Off sensor ① is recessed and reacts to touch.











It is used for switching the oven on and off.

Function selector

For selecting oven functions.

It can be turned clockwise or anti-clockwise and in the • position, can be retracted by pressing it in.

Functions

-  *Conventional heat*
-  *Bottom heat*
-  *Grill*
-  *Gentle bake*
-  *Moisture plus*
-  *Rapid heat-up*
-  *Fan plus*
-  *Intensive bake*
-  *Fan grill*
-  *Pyrolytic cleaning*













Display

The display shows the time of day or your settings.



Symbols in the display

Depending on the position of the function selector  and/or whether a sensor has been pressed, the following symbols appear:

Symbol/function		
	Minute minder	Any
	Temperature indicator light	Function
	Temperature	
	Duration	
	End of cooking duration	
	Water intake process	
	Descaling	
	Bursts of steam	
	Settings <i>P</i>	•
	Time of day	
	System lock	

You can only set or change a function if the function selector is in the correct position.

Rotary selector < >

Use the rotary selector < > to enter temperatures and durations.

Turning it clockwise will increase the values, and turning it anti-clockwise will decrease them.

It can also be used to highlight a function by moving the triangle  in the display.

It can be turned clockwise or anti-clockwise. It can be retracted in any position by pressing it in.

















Oven controls

Sensor controls

The sensors react to touch. Each touch is confirmed with a keypad tone. This keypad tone can be switched off by changing setting *P 3* to Status *5 0* (see “Settings”).

Sensor	Function	Notes
OK	For selecting functions and saving settings	Functions marked with triangle ▲ can be selected by touching OK. The selected function can be changed whilst triangle ▲ is flashing. Touch OK to save changes.
↶	To go back a step	
🔔	For setting the minute minder	If the time of day is visible you can enter a minute minder duration at any time, e.g. when boiling eggs on the hob. If the display is dark, this sensor will not react until the oven is switched on.

Oven controls

Sensor	Function	Notes
	For switching the oven interior lighting on and off	<p>If the time of day display is visible, the oven interior lighting can be switched on and off by touching the  sensor.</p> <p>If the display is dark, this sensor will not react until the oven is switched on.</p> <p>The oven interior lighting switches off after 15 seconds during a cooking process or remains constantly switched on, depending on the setting selected.</p>
	To select a function	<p>If the time of day is visible in the display and the rotary selector is at the  position, the symbols for settings , time of day  and system lock  will appear when the  sensor is touched.</p> <p>If the display is dark, this sensor will not react until the oven is switched on.</p> <p>Whilst cooking you can set the temperature , the cooking duration  and the finish time  depending on how this sensor is set up.</p>
	For injecting the bursts of steam	<p>If manual bursts of steam are selected for the Moisture plus function , the bursts of steam are injected by touching the  sensor.</p> <p>The  sensor lights up when a burst of steam can be injected.</p> <p> appears in the display when a burst of steam is being injected.</p>

Features

Model numbers

A list of the models described in these operating instructions can be found on the back page.

Data plate

The data plate is located on the front frame, visible when the door is open.

The data plate states the model number of your oven, the serial number as well as connection data (voltage, frequency and maximum connected load).

Please have this information to hand, should you need to contact Miele regarding any questions or problems.

Items supplied

The oven is supplied with:

- the operating and installation instructions for using the oven,
- screws for securing your oven in the housing unit,
- descaling tablets and a plastic tube with suction cup for descaling,
- various accessories.

Accessories supplied and available to order

Accessories will vary depending on model.

Your oven will be supplied with side runners, a universal tray and a rack. Depending on model, your oven may also come supplied with some or several of the accessories listed here.

All the accessories listed as well as the cleaning and care products are designed for Miele ovens.

These are available to order via the Miele Webshop, the Miele Spare Parts Department (see end of this booklet for contact details) or from your Miele dealer.

When ordering, please quote the model number of your oven and the reference number of the accessories required.

Side runners

Side runners for trays, racks and Miele oven dishes are fitted on either side of the oven cavity for shelf levels .

The numbers for the shelf levels are marked on the front frame.

Each level consists of two rails, one above the other.

The accessories (e.g. the rack) are pushed into the oven between the two rails.

FlexiClip telescopic runners (depending on model) are fitted on the lower rail.

The side runners can be removed for cleaning (see “Cleaning and care”).

Baking tray, universal tray and rack with non-tip notches

Baking tray HBB 71:

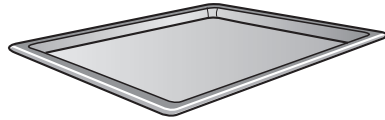

Universal tray HUBB 71:

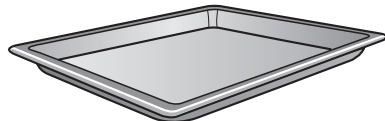

Rack HBBR 72:

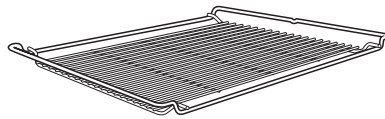

These accessories are inserted into the oven between the two rails of a side runner.

Always position the rack as illustrated.

The accessories have non-tip safety notches half way along the short edges which prevent them from being pulled right out when they only need to be pulled partially out.



If you are using the universal tray with the rack on top, insert the tray between the rails of the side runners and the rack will automatically slide in above them.

Features

FlexiClip telescopic runners HFC 72

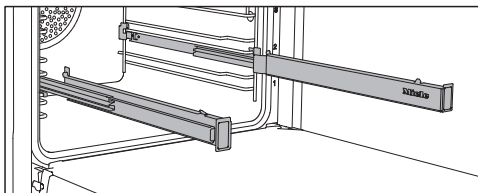

The FlexiClip telescopic runners can be used with any shelf level.

Push the FlexiClip telescopic runners right into the oven before placing accessories on them.

The accessories will then automatically sit securely in between the stoppers at either end of each runner and be prevented from sliding off.

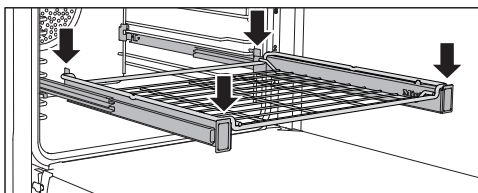
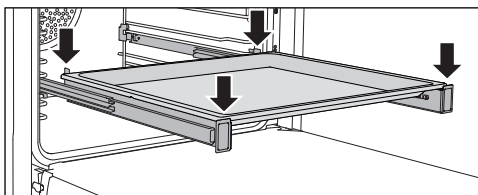

The FlexiClip runners can support a maximum load of 15 kg.

Fitting and removing FlexiClip telescopic runners

 **Danger of burning.**
Make sure the oven heating elements are switched off and cool.

The FlexiClip runners are fitted in between the two rails that make up a shelf level.

The FlexiClip runner with the Miele logo is fitted on the right.

When fitting the FlexiClip telescopic runners **do not** extend them.

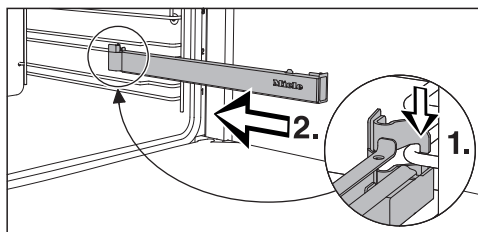

- Hook the FlexiClip runner onto the front of the lower rail of a side runner (1.) and then push it along the rail into the oven compartment (2.).

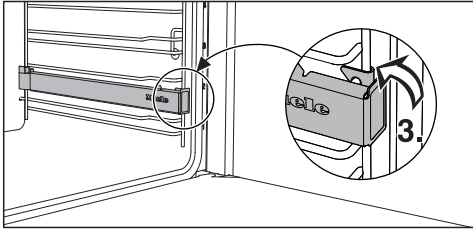

- Then secure the FlexiClip runner to the lower of the two rails as illustrated (3).

If the FlexiClip runners are difficult to pull out after fitting, you may need to pull firmly on them once to release them.

To remove a FlexiClip runner:

- Push the FlexiClip runner in all the way.

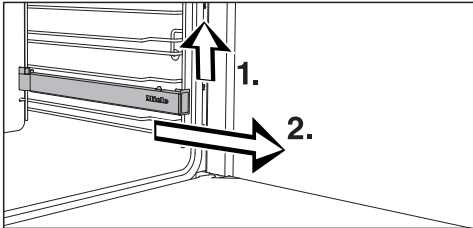

- Remove the FlexiClip runner by raising it at the front (1) then pulling it forwards along the rail and out (2).

Round baking tray HBF 27-1



The round baking tray is suitable for cooking pizza, shallow cakes made with yeast or whisked mixtures, sweet and savoury tarts, baked desserts, flat bread, and can also be used for frozen cakes and pizzas.

The enamelled surface has been treated with PerfectClean.

Perforated baking tray HBBL 71

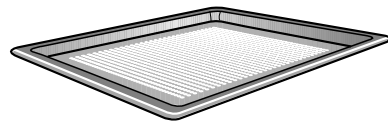

The perforated baking tray has been specially designed for baking fresh yeast and quark dough items, bread and rolls.

The fine perforations help to brown the underside of food.

The tray can also be used for drying fruit and vegetables.

The enamelled surface has been treated with PerfectClean.

The round perforated baking tray HBFP 27-1 can be used for the same things.

Features

Baking stone HBS 60

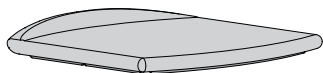

The baking stone is ideal for items which need a well baked base such as pizza, quiche, bread, bread rolls and savoury snacks.

The baking stone is made from heat retaining fire brick and is glazed. Place it directly on the rack.

A paddle made of untreated wood is supplied with it for placing food on the baking stone and taking it off.

Anti-splash insert HGBB 71

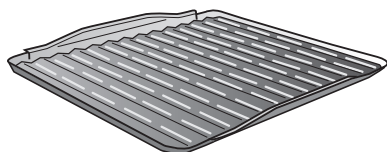

The anti-splash insert fits in the universal tray.

The juices from the food being grilled or roasted collect under the insert. This prevents them from spitting and making the oven dirty. The juices can then be used for making gravy and sauces.

The enamelled surface has been treated with PerfectClean.

HUB Gourmet oven dishes HBD Gourmet oven dish lids

The Miele gourmet oven dishes, unlike other oven dishes, slide into the oven on the side runners. They have non-tip safety notches like the rack to prevent them being pulled out too far. They also have a non-stick coating.

Gourmet oven dishes are available in two sizes. The width and the height are the same for both.

Suitable lids are available separately. Please quote the model number when ordering a lid.

Depth: 22 cm

HUB 5000-M
HUB 5001-M *

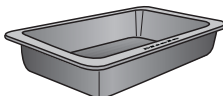

HBD 60-22

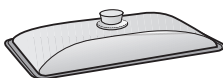

Depth: 35 cm

HUB 5001-XL *

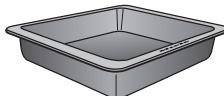

HBD 60-35



* suitable for use on induction hobs

Handle HEG

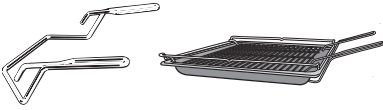

The handle makes it easier to take the universal tray, baking tray and rack out of the oven, or to put them into it.

Descaling tablets, plastic tube with suction cup

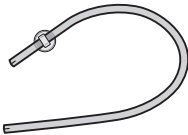

These are required for descaling the appliance.

Miele microfibre cloth

Light soiling and fingerprints can be easily removed with the microfibre cloth.

Miele oven cleaner

Miele oven cleaner is suitable for removing very stubborn soiling. It is not necessary to pre-heat the oven beforehand.

Features

Oven controls

The oven controls are used to operate the various cooking functions for baking, roasting and grilling.

They are also used for

- Time of day display
- Minute minder
- Switching cooking processes on and off automatically
- Moisture plus cooking
- Selecting settings

Safety features

System lock

The system lock prevents the oven from being used unintentionally (see “System lock ”).

The system lock will remain activated even after an interruption to the power supply.

Cooling fan

The cooling fan will come on automatically when a cooking programme is started. The cooling fan mixes hot air from the oven cavity with cool room air before venting it out into the kitchen through vents located between the appliance door and the control panel.

The cooling fan will continue to run for a while after the oven has been switched off to prevent any humidity building up in the oven, on the control panel or in the oven housing unit.

This cooling fan will switch itself off automatically after a certain period of time.

Vented oven door

The oven door glass panes have a heat-reflecting coating.

When the oven is operating, air is passed through the door to keep the outer pane cool.

The door can be removed and dismantled for cleaning (see “Cleaning and care”).

Door lock - Pyrolytic cleaning

For safety reasons the door is locked as soon as the Pyrolytic cleaning programme is started. After the Pyrolytic cleaning programme has finished, the door will remain locked until the temperature in the oven has fallen below 280 °C.

PerfectClean treated surfaces

PerfectClean surfaces have very good non-stick properties and are much easier to keep clean than conventional enamel surfaces, if cleaned regularly.

Food can be taken off these surfaces easily, and soiling from baking and roasting is simple to remove.

Food can be sliced or cut up on PerfectClean surfaces.

Do not use ceramic knives as these will scratch the PerfectClean surface.

Surfaces treated with PerfectClean enamel can be cleaned as you would clean glass.

Read the instructions in “Cleaning and care” so that the benefits of the non-stick properties and easy cleaning are retained.

The following have all been treated with PerfectClean:

- Universal tray
- Baking tray
- Anti-splash insert
- Perforated baking tray
- Round baking tray
- Round perforated baking tray

Pyrolytic accessories

The following accessories can be left in the oven during the Pyrolytic cleaning programme.

- Side runners
- FlexiClip telescopic runners
- Rack

See “Cleaning and care” for more information.

Before using for the first time

Before using for the first time

 The oven must not be operated until it has been correctly installed in its housing unit.

- Press and release the function and rotary selectors < > if they are retracted.

The time of day can only be changed when the function selector is at •.

- Set the time of day.

Setting the time of day for the first time

The time of day is shown in 24 hour clock format.

After connecting the oven to the electricity supply, *12:00* will appear in the display and the triangle ▲ will flash under :



- Use the rotary selector < > to enter the time of day.
- Confirm with OK.

The time of day is now saved.

The time of day can be displayed in 12 hour format by setting *P 4* in the settings menu to status *12h* (see “Settings”).

In the event of a power cut the time of day is saved for approx. 200 hours. If power is restored within this time the current time of day is displayed. After a longer power cut, the time of day needs to be re-entered.

The time of day display is switched off by default (see “Settings – *P 1*”). The display appears dark if the oven is switched off. The time of day continues to run unseen in the background.

Before using for the first time

Heating up the oven for the first time and rinsing the steam injection system

New ovens can give off an unpleasant smell on first use. Heating up the oven for at least 1 hour with nothing in it will get rid of this smell. It is a good idea to rinse the steam injection system at the same time.

Ensure that the kitchen is well ventilated during this operation. Close doors to other rooms to prevent the smell spreading throughout the house.

- Remove any stickers or protective foil from the oven and accessories.
- Before heating the oven up, wipe the interior with a damp cloth to remove any dust or bits of packaging that may have accumulated in the oven cavity during storage and unpacking.
- Fit the FlexiClip runners (available to order) to the side runners and insert all trays and the rack.

- Fill a container with approx. 100 ml of fresh tap water.
- Switch the oven on with the On/Off sensor ①.
- Select Moisture plus  with the rotary function selector.

The oven heating, lighting and cooling fan will switch on.

Auto appears in the display with the triangle ▲ flashing under .



- Confirm with OK.

The recommended temperature will appear in the display with the triangle ▲ flashing under :



- Use the rotary selector < > to set the maximum possible temperature (250 °C).
- Confirm with OK.

Before using for the first time

The prompt for water intake appears and the triangle ▲ flashes:



- Open the door.
- Pull the water intake pipe forwards (located below the control panel on the left).

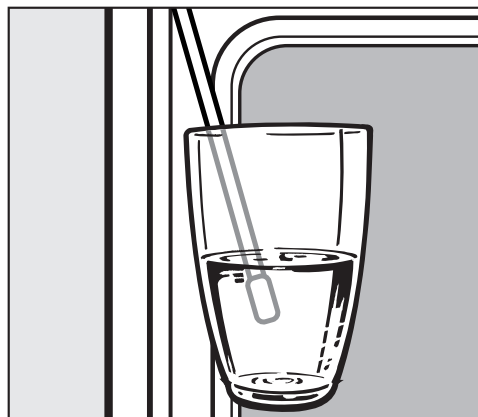

- Immerse the end of the water intake pipe in the container with the tap water.
- Confirm with *OK*.

The water intake process will begin.

The amount of water required will be drawn up into the oven. The quantity of water specified is higher than actually required, leaving a small amount in the container.

- Remove the water container after the water intake process.
- Close the door.

You will hear the pump briefly as the remaining water in the water intake pipe is drawn into the oven.

After a short time a burst of steam is injected automatically.

 Risk of injury!
Steam can cause scalding.
Do not open the door during a steam burst.



Heat the empty oven for at least an hour.

After at least an hour:

- Turn the function selector to ●.

After heating up for the first time

 Danger of burning. Allow the oven to cool down before cleaning by hand.

- Switch the oven on with the On/Off sensor .
- Switch the oven light on with the  sensor.
- Take all accessories out of the oven and clean them by hand (see “Cleaning and care”).
- Clean the oven interior with a clean sponge and a solution of hot water and washing-up liquid or a damp microfibre cloth.
- Dry all surfaces with a soft cloth.
- Switch the interior lighting and the oven off.

Leave the oven door open until the oven interior is completely dry.

Settings

Altering the time of day

The time of day can only be changed when the oven is switched on and the function selector is at •.

- Switch the oven on.
- Select '≡.
- Use the rotary selector < > to move the triangle ▲ until it lights up under ⌚.
- Confirm with OK.

The triangle ▲ will flash under ⌚.

- Use the rotary selector < > to enter the time of day.
- Confirm with OK.

The time of day is now saved.

In the event of a power cut the time of day is saved for approx. 200 hours. If power is restored within this time the current time of day is displayed.

After a longer power cut, the time of day needs to be re-entered.

Changing factory default settings

Your appliance is supplied with a number of standard default settings (see the “Settings overview” chart).

A setting is changed by altering its status.

Settings can only be changed when the oven is switched on and the rotary selector is at ●.

- Select '≡.
- If necessary use the rotary selector < > to move the triangle ▲ under '≡.



- Confirm with OK.

A setting will appear:



- If you wish to change another setting, use the rotary selector < > to select the appropriate number.
- Confirm with OK.



The setting is selected and the current status appears, e.g. 5 0.

To alter the status:

- Use the rotary selector < > to select the status you want.
- Confirm with OK.



The selected status is saved and the setting appears again.

- If you wish to alter more settings, proceed as described previously.
- Select ↶ if you have not changed one setting and wish to switch to another.
- Select '≡ if you do not want to change any more settings.

The settings remain in memory even after a power cut.

Settings

Settings overview

Setting	Status
<p><i>P 1</i> Time of day display</p>	<p><i>S 0</i> * The time of day display is switched off. The display is dark when the oven is switched off. The time of day continues to run unseen in the background. If you have selected status <i>S 0</i> you have to switch the oven on before you can use it. The same applies to setting a minute minder time  or switching the oven lighting  on. The oven also switches off automatically if no settings are selected within a certain period of time (approx. 30 minutes).</p> <p><i>S 1</i> The time of day display is switched on and is visible in the display.</p>
<p><i>P 2</i> Buzzer volume</p>	<p><i>S 0</i> The buzzer is switched off.</p> <p><i>S 1-</i> The buzzer is switched on.</p> <p><i>S 2!</i> The volume can be altered. When you select a status you will hear the corresponding buzzer.</p> <p><i>S 7</i> *</p>
<p><i>P 3</i> Keypad tone</p>	<p><i>S 0</i> Keypad tone deactivated.</p> <p><i>S 1</i> * Keypad tone activated.</p>
<p><i>P 4</i> Clock format</p>	<p><i>24h</i> * The time of day is shown in 24 hour format.</p> <p><i>12h</i> The time of day is shown in 12 hour format. If you change the clock after 13:00 from a 12 hour clock to a 24 hour clock you will need to update the hour accordingly.</p>

* Factory default setting

Setting	Status
<i>P 5</i> Temperature unit	<p>°C* The temperature is displayed in degrees Celsius.</p> <p>°F The temperature is displayed in degrees Fahrenheit.</p>
<i>P 6</i> Display brightness	<p>5 1– 5 7, 5 4* 5 1: minimum brightness 5 7: maximum brightness.</p>
<i>P 7</i> Lighting	<p>5 0* The oven interior light is switched on for 15 seconds and then switches off automatically.</p> <p>5 1 The oven interior light is switched on constantly.</p>
<i>P 8</i> Demo mode	<p>5 0* Select 5 0 and touch <i>OK</i> for approx. 4 seconds. As soon as - - - - appears briefly, demo mode is deactivated.</p> <p>5 1 Select 5 1 and touch <i>OK</i> for approx. 4 seconds. As soon as <i>DE5_</i> appears briefly, demo mode is activated. The oven can be operated, but the oven heating and the pump for the moisture evaporation system will not work. Do not use this setting for personal use.</p>

* Factory default setting

System lock

The system lock  prevents the oven from being used unintentionally, for example by children.





The oven is delivered with the system lock deactivated.

The setting for the system lock can be changed by altering status *S*:

- *S 0* = off
- *S 1* = on

The status of the system lock can only be altered when the oven is switched on and the rotary selector is at .

Activating the system lock

- Select .
- Use the rotary selector  to move the triangle  until it lights up under .

The currently set status *S 0* appears:



- Confirm with *OK*.
- Use the rotary selector  to set the status *S 1*.



- Confirm with *OK*.
- Select .

The current time of day will appear.

- Switch the oven off.



The system lock is activated.

When the oven is switched on again the  symbol will appear in the display to remind you that the system lock has been activated.

The system lock will remain activated even after an interruption to the power supply.

Deactivating the system lock for a cooking process

- Switch the oven on.



The  and  symbols and the current time of day will appear:



- Touch *OK* until  goes out.

The oven can now be used.

Deactivating the system lock

- Switch the oven on.
- Touch *OK* until  goes out.
- Select *≡*.
- Use the rotary selector *< >* to move the triangle  until it lights up under .
- Confirm with *OK*.

The currently set status *5 l* appears.

- Use the rotary selector *< >* to set the status *5 0*.
- Confirm with *OK*.
- Select *≡*.

The system lock is switched off.

The  symbol disappears.

Minute minder

The minute minder can be used to time other activities in the kitchen, e.g. boiling eggs.

The minute minder can also be used at the same time as a cooking programme in which the start and finish times have been set, e.g. as a reminder to stir a dish or add seasoning etc.

A maximum minute minder time of 99 minutes and 55 seconds can be set.



Tip: Use the Minute minder when using Moisture plus  to remind you to inject the bursts of steam at the desired time.

To set the minute minder

Example: You want to boil some eggs and set a minute minder duration of 6 minutes and 20 seconds.

If you have switched the clock display off (setting "P1 - 5 0"), you will need to switch the oven on before you can set a minute minder duration.

- Select .

00:00 will appear in the display with the triangle  under :



- Use the rotary selector < > to set the minute minder duration you require.





- Confirm with OK.

The minute minder is saved and will count down in seconds.



The  symbol indicates the minute minder has been set.

At the end of the minute minder duration

-  will flash.
 - The display will show the time counting upwards.
 - A buzzer will sound if the buzzer is switched on (see “Settings – P 2”).
- Select .

The buzzer will stop and the symbols in the display will go out.

To change the duration

- Select .

The minute minder duration selected appears.

- Use the rotary selector < > to set the minute minder duration.
- Confirm with OK.

The changed minute minder duration is saved and will count down in seconds.

To cancel the time set for the minute minder







- Select .

- Use the rotary selector < > to reduce the minute minder duration 00:00.
- Confirm with OK.







The minute minder duration is now cancelled.

Overview of functions

Your oven has a range of oven functions for preparing food.





Function	Recommended temperature	Temperature range
Fan plus  This function is used for baking and roasting on different levels at the same time. A lower temperature can be selected than when using Conventional heat  , as the fan distributes the heat around the oven compartment straight away.	160 °C	30–250 °C
Moisture plus  For baking and roasting with moisture injection. First <i>Auto</i> will appear in the display and the triangle ▲ will flash under the  symbol. The recommended temperature will only appear after the number of bursts of steam has been selected.	160 °C	130–250 °C
Intensive bake  For baking cakes with moist toppings. Intensive bake is not suitable for baking thin biscuits or for roasting as the juices will become too dark.	170 °C	50–250 °C
Conventional heat  For baking and roasting traditional recipes, cooking soufflés and cooking at low temperatures. If using an older recipe or cookbook, set the oven temperature for Conventional heat 10 °C lower than that recommended. This will not change cooking times.	180 °C	30–280 °C

Overview of functions

Function	Recommended temperature	Temperature range
Bottom heat  Use this setting towards the end of cooking to brown the base of a cake, quiche or pizza.	190 °C	100–250 °C
Grill  For grilling larger quantities of thin cuts (e.g. steak) and browning baked dishes. The whole of the grill glows red to create the required level of heat.	240 °C	200–300 °C
Fan grill  For grilling thicker cuts of meat (e.g. chicken). Lower temperatures can be used than when using the Grill  function, as the fan distributes the heat around the oven compartment straight away.	200 °C	100–260 °C
Gentle bake  For small amounts e.g. of frozen pizza, bake-off rolls, cookies and for meat dishes and roasts. You can save up to 30 % energy compared to cooking with a standard oven function as long as the door is kept shut during cooking.	190 °C	100–250 °C
Rapid heat-up  For pre-heating the oven quickly. The oven function required must then be selected.	160 °C	100–250 °C

Tips on saving energy

Cooking

- Remove any accessories from the oven that you do not require for cooking.
- Pre-heat the oven only if instructed to do so in the recipe or the cooking chart.
- Avoid opening the door during cooking.
- In general, if a range of temperatures is given, it is best to select the lower temperature and to check the food after the shortest given time.
- It is best to use dark baking tins and containers with a matt finish made from non-reflective materials (enamelled steel, oven-proof glassware, non-stick coated cast aluminium). Shiny materials such as stainless steel or aluminium reflect heat, preventing it reaching the food efficiently. Do not cover the oven floor or the rack with heat-reflective aluminium foil.
- Observe cooking durations to avoid energy wastage when cooking food.
- Wherever possible set the cooking duration, or use a food probe.
- Fan plus  can be used for cooking many types of food. Because the fan distributes the heat to food straight away, it allows you to use a lower temperature than you would with Conventional heat . It also enables you to cook on several shelf levels at the same time.
- Gentle bake  is an innovative function that makes optimum use of heat. You can save up to 30 % energy compared to cooking with a standard oven function as long as the door is kept shut during cooking.
- Fan grill  can be used for a wide variety of food. With Fan grill you can use lower temperatures than with other grill functions which use the maximum temperature setting.
- Whenever possible you should cook several dishes at the same time. Place them next to each other in the oven or on different shelf levels.
- Dishes which you are unable to cook at the same time should, if possible, be cooked one after the other in order to make use of existing heat in the oven.

Using residual heat

- The temperature in cooking programmes using temperatures above 140 °C which take longer than 30 minutes to cook can be turned down to the lowest possible temperature about 5 minutes before the end of cooking. The residual heat in the oven is sufficient for cooking the food. Do not switch the oven off (see “Warning and safety instructions”).
- If you wish to run the pyrolytic cleaning programme, it is best to start it immediately after a cooking programme. The residual heat in the oven will help reduce the amount of energy required to run the programme.

Settings

- Switch the clock display off if you wish to reduce energy usage (see “Settings”).
- Set the oven lighting so that it switches off automatically during a programme after 15 seconds. It can be switched on again at any time by touching .

Energy save mode

- The oven will switch itself off automatically to save energy if a programme is not being run and controls have not been operated. The time of day will appear in the display or the display will remain dark (see “Settings”).

Using the oven

Simple operation

- Switch the oven on.
- Place the food in the oven.
- Select the required oven function with the function selector.

The recommended temperature will appear:



The oven heating, lighting and cooling fan will switch on.

- Use the rotary selector < > to change the temperature if necessary.

The current temperature and temperature indicator light  will appear after a short time.



You can follow the temperature increasing. A buzzer will sound when the required oven temperature is first reached if this option is selected (see “Settings - P 2”).

After cooking:

- Turn the function selector to •.
- Take the food out of the oven.
- Switch the oven off.

Cooling fan

The cooling fan will continue to run for a while after the oven has been switched off to prevent any humidity building up in the oven, on the control panel or in the oven housing unit.

This cooling fan will switch itself off automatically after a certain period of time.

To alter the temperature

Example: You have selected Fan plus  and 170 °C and can see the temperature increasing.



You want to reduce the target temperature to 155 °C.

- Use the rotary selector < > to reduce the temperature.

The triangle ▲ will flash under  and the temperature is altered in 5 °C steps.





The altered target temperature is saved.
The actual temperature is displayed.

Use  to change between displaying the current and target temperatures.

Temperature indicator light

The temperature indicator light  lights up when the oven is heating.

The temperature indicator light  lights up during the heating-up phase.

When the required temperature is first reached a buzzer will sound if the buzzer is activated (see “Settings – P 2”). At the same time the oven heating will switch itself off and  will go out.

The temperature control unit ensures that the oven heating and the temperature indicator light  switch back on when the temperature in the oven temperature falls below the level set.

Using the oven

Pre-heating the oven

It is only necessary to pre-heat the oven in a few instances.

Most dishes can be placed in a cold oven. They will then make use of the heat produced during the heating-up phase.

Pre-heat the oven when cooking the following food with the following oven functions:

Fan plus

- dark bread dough
- beef sirloin joints and fillet



Conventional heat

- cakes and biscuits with a short baking time (up to 30 minutes)
- delicate mixtures (e.g. sponges)
- dark bread dough
- beef sirloin joints and fillet

Rapid heat-up

With Rapid heat-up  the heating up phase can be shortened.

Do not use Rapid heat-up  to pre-heat the oven when baking pizzas or biscuits and small cakes. They will brown too quickly on top.

- Select Rapid heat-up .
- Select a temperature.
- When the temperature indicator light  goes out for the first time, set the oven function you require for continued cooking.
- Place the food in the oven.

Switching on and off automatically

Cooking programmes can be switched off, or on and off automatically. To do this, set a duration or a duration and finish time after selecting an oven function and a temperature.

The maximum duration which can be set for a cooking programme is 12 hours.

We recommend switching on and off automatically when roasting. If using it for baking, do not delay the start for too long as the cake mixture or dough will dry out, and the raising agents will lose their effectiveness.

Setting the cooking duration



Example: to bake a cake for 1 hour 5 minutes



- Place the food in the oven.
- Select the required oven function and the temperature.

The oven heating, lighting and cooling fan will switch on.

- Select .



- If necessary use the rotary selector $< >$ to move the triangle  under .
- Confirm with OK.

00:00 will appear in the display with the triangle  flashing under .



- Use the rotary selector $< >$ to set the cooking duration (01:05).
- Confirm with OK.

The cooking duration is saved and then counts down in minutes, with the last minute counting down in seconds.

The  symbol indicates a cooking duration has been set.

Using the oven

Setting a cooking duration and finish time

Example: the time is now 11:15; you want a dish with a cooking duration of 90 minutes to be ready at 13:30.

- Place the food in the oven.
- Select the required oven function and the temperature.

The oven heating, lighting and cooling fan will switch on.

Set the cooking duration first:

- Select \equiv .
- If necessary use the rotary selector $< >$ to move the triangle \blacktriangle under ⌚ .
- Confirm with *OK*.

00:00 will appear in the display with the triangle \blacktriangle flashing under ⌚ .

- Use the rotary selector $< >$ to set the cooking duration (01:30).
- Confirm with *OK*.

The cooking duration is saved and then counts down in minutes:



Now set the finish time:

- Use the rotary selector $< >$ to move the triangle \blacktriangle until it lights up under ⌚ .

-- -- will appear:



- Confirm with *OK*.

As soon as you turn the rotary selector $< >$ clockwise 12:45 will appear (= current time of day + cooking duration = 11:15 + 1:30):



- Use the rotary selector $< >$ to enter the finish time (13:30).
- Confirm with *OK*.

The finish time ⌚ is now saved:

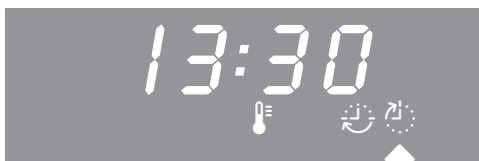

The oven heating, lighting and cooling fan will switch off.



As soon as the start time (13:30 - 1:30 = 12:00) is reached, the oven heating, lighting and cooling fan will switch on.

At the end of the cooking duration

- 0:00 will appear.
-  will flash.
- A buzzer will sound if the buzzer is switched on (see “Settings – P 2”).
- The oven heating and lighting will switch off automatically.
- The cooling fan continues to run.
- Turn the function selector to •.
- Take the food out of the oven.
- Switch the oven off.

If the dish is not cooked to your satisfaction you can prolong the cooking duration by entering a new duration.

Changing the cooking duration

- Select .
- If necessary use the rotary selector < > to move the triangle ▲ under .

The cooking duration remaining will appear in the display.

- Confirm with *OK*.
- Use the rotary selector < > to alter the cooking duration.
- Confirm with *OK*.

The altered cooking duration is now saved.

Using the oven

Deleting a cooking duration

- Select '≡.
- If necessary use the rotary selector < > to move the triangle ▲ under 🕒.
- Confirm with *OK*.

The triangle ▲ will flash under 🕒.

- Use the rotary selector < > to set the cooking duration to 00:00.
- Confirm with *OK*.

The cooking duration and any finish time will be deleted.

- Select '≡.

The current temperature will appear.
The oven heating remains switched on.

If you want to finish the cooking programme:

- Turn the function selector to •.
- Take the food out of the oven.
- Switch the oven off.

If you turn the function selector to • or switch the oven off, the settings for the cooking duration and the finish time will be deleted.

Deleting a finish time

- Select '≡.
- If necessary use the rotary selector < > to move the triangle ▲ under 🕒.
- Confirm with *OK*.

The triangle ▲ will flash under 🕒.

- Use the rotary selector < > to set the finish time to - :- -.
- Confirm with *OK*.

The finish time is now deleted.

Your oven is equipped with a steam injection system for cooking with moisture. Baking, roasting and cooking with Moisture plus  guarantees optimised steam and air conduction for excellent cooking and browning results.

After selecting Moisture plus  you need to set the number of bursts of steam.

The options are:

- Automatic burst of steam (*Auto*)
This requires enough water for one burst of steam. The burst of steam will be injected into the oven automatically after the heating-up phase.
- 1 burst of steam (1)
- 2 bursts of steam (2)
- 3 bursts of steam (3)
You need to add the appropriate amount of water for the number of bursts of steam. You have to release the bursts of steam yourself.

Finally set the temperature and start the process to draw in water.

Fresh tap water is taken into the steam system via the tube underneath the control panel on the left.

 Liquids, other than water, can cause damage to the oven.
Only use tap water when cooking with the “Moisture plus” function.

The water is then injected as bursts of steam into the oven compartment during the cooking programme. The steam inlets are located at the rear left corner of the roof of the oven.

One burst of steam takes approx. 5–8 minutes. The number of bursts of steam and when they are injected will depend on the type of food being cooked:

- **Yeast mixtures** will rise better if steam is injected at the beginning of the programme.
- **Bread and rolls** also rise better if exposed to steam at the start. Injecting a burst of steam at the end of the programme will give the bread and rolls a glistening crust.
- When **roasting meat with a high fat content** injecting steam at the beginning of roasting will help render the fat.

Additional moisture is not suitable for mixtures which already contain a lot of moisture, such as choux pastry and meringues, as the addition of steam does not allow them to dry out sufficiently.

Tip: Use the recipes as a guide.

Moisture plus

Moisture plus function

It is quite normal for condensation to form on the inside of the door during steam injection. This will dissipate during the course of the cooking programme.

- Prepare the food and place in the oven.
- Fill a suitable container with the amount of water required:
 - Auto* Approx. 100 ml
 - 1* Approx. 100 ml
 - 2* Approx. 200 ml
 - 3* Approx. 300 ml
- Select the Moisture plus  function.

Set the number of bursts of steam

Auto appears in the display with the triangle ▲ flashing under .



The other steam burst options (*1*, *2*, *3*) can be selected using the rotary selector < >.

After *3*, *E* appears in the display. This option starts the descaling process (see “Descaling the steam injection system ”).

Tip: Use the recipes as a guide.

- If you want the oven to release a burst of steam automatically after the heating-up phase, select *Auto* and confirm with *OK*.
- If you want to inject one or more bursts of steam manually at specific times, select *1*, *2* or *3* and confirm your choice with *OK*.

Set the temperature

The recommended temperature will appear in the display with the triangle ▲ flashing under :



- If necessary, set the temperature using the rotary selector < >.
- Confirm with *OK*.

Start the water intake process

The prompt for the water intake process will appear. Triangle ▲ will flash under :



- Open the door.
- Pull the water intake pipe forwards (located below the control panel on the left).

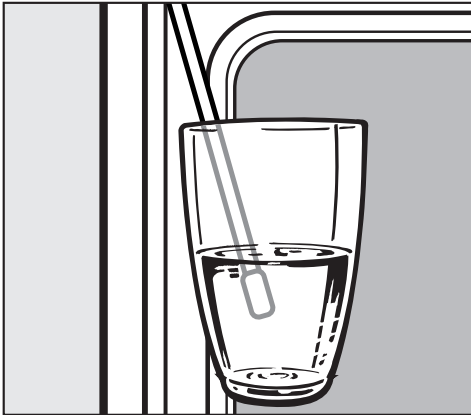

- Immerse the end of the water intake pipe in the container with the tap water.
- Confirm with OK.

The water intake process will begin.

The amount of water actually drawn up into the oven may be less than the amount specified as required, leaving a small amount in the container.

The water intake process can be interrupted and restarted at any time with OK.

- Remove the water container after the water intake process.
- Close the door.

You will hear the pump briefly as the remaining water in the water intake pipe is drawn into the oven.

The current temperature and the temperature indicator light  will appear.



You will see the temperature increasing. A buzzer will sound when the oven temperature is reached if this option is selected (see "Settings - P 2").

Injecting bursts of steam

 Steam can cause scalding. Do not open the door during bursts of steam. Also, condensation on the sensors will cause them to have a slow reaction time.

Automatic burst of steam

Once the heating-up phase has been completed, the automatic burst of steam is injected. The following will appear in the display:



The water will vaporise in the oven compartment.

After the burst of steam,  will go out and the temperature will be displayed.

- Continue cooking until the end of the cooking duration.

Injecting bursts of steam manually

The bursts of steam can be injected as soon as  lights up in the display.

Please wait until the heating-up phase is completed to allow the steam to be distributed evenly by the warm air in the oven.

Please refer to the recipes for the timing of the bursts of steam.

Tip: Set the minute minder  to remind you when to do so.

- Touch  to inject the burst of steam.

The sensor light goes out and the following appears in the display:



- Proceed as described to inject further bursts of steam.



After the last burst of steam  will go out and the temperature will be displayed.

- Continue cooking until the end of the cooking duration.

Residual water evaporation

When cooking using the Moisture plus  function, the water will be equally distributed between the number of bursts of steam and used up as long as the programme is not interrupted.

However, if a programme using the addition of moisture is interrupted before all the bursts of steam have been injected, the water for these unused bursts of steam will remain in the system.

The next time the Moisture plus  function is selected, a time will appear and triangle ▲ will flash under the  symbol to prompt you to evaporate the residual moisture.

The time shown in the display will depend on the amount of residual water in the system.

It is best to start the evaporation of residual water straight away so that only fresh water is used during a cooking programme.

The residual water evaporation process

The oven will heat up and the residual water in the oven cavity will evaporate.

Depending on the amount of water this can take up to 30 minutes.

Steam can cause scalding.
Do not open the door while the residual water is being evaporated.

During the evaporation process moisture will condense on the door and the oven interior. This condensation must be wiped off after the oven has cooled down.

Moisture plus

To start residual water evaporation immediately

- Select the Moisture plus  function.

A time, depending on the amount of residual water present, will appear and the triangle ▲ will flash under :



- Confirm with OK.

The evaporation process will begin. The duration will count down in the display.

During the evaporation process, the duration may be adjusted by the system according to the amount of water currently present.



The last minute counts down in seconds.

At the end of the residual water evaporation process *Auto* will appear:



A cooking process using the Moisture plus function  can now be carried out.

To cancel the residual water evaporation process

 Skipping the residual moisture evaporation process can, in certain cases, cause water to overflow into the oven cavity.

It is best not to cancel the evaporation process.

- Select the Moisture plus  function.

A time, depending on the amount of residual water present, will appear and the triangle ▲ will flash under 



- Turn the rotary selector < > anti-clockwise

The time will be set to 00:00 :



- Confirm with OK.

Auto will appear:







A cooking process using the Moisture plus function  can now be carried out.

Baking

Eating food which has been cooked correctly is important for good health.





Only bake cakes, pizza, chips etc. until they are golden. Do not overcook them.

Functions

Depending on how the food is prepared, you can use Fan plus , Intensive bake , Moisture plus  or Conventional heat .

Bakeware

The choice of bakeware depends on the oven function.

- Fan plus , Intensive bake , Moisture plus :
Baking tray, universal tray, bakeware of any ovenproof material.
- Conventional heat :
Dark baking tins with a matt finish. Avoid using bright, shiny metal tins as they give an uneven and poor browning result and in some cases cakes might not cook properly.
- Always place baking tins on the rack. Position rectangular tins with the longer side across the width of the rack for optimum heat distribution and even baking results.
- When baking cakes with fresh fruit toppings and deep sponge cakes place the tin in the universal tray to catch any spillages.

Baking paper, greasing the tin

Miele accessories, e.g. the universal tray are treated with PerfectClean enamel (see “Features”).

Surfaces treated with PerfectClean enamel generally do not need to be greased or covered with baking paper.

Baking paper should be used with:

- anything prepared using a lye containing sodium hydroxide (e.g. pretzels, bread sticks) because the lye can damage the PerfectClean surface,
- meringues or sponges with a high egg-white content because they are more likely to stick,
- frozen food cooked on the rack.

Notes on using the baking charts

The data for the recommended function is printed in bold.

Unless otherwise stated, the durations given are for an oven which has not been pre-heated. With a pre-heated oven, shorten durations by up to 10 minutes.

Temperature

As a general rule, select the lower temperature given in the chart.

Baking at temperatures higher than those recommended may reduce the cooking time, but will lead to uneven browning, and unsatisfactory cooking results.

Duration

Check if the food is cooked at the end of the shortest time quoted. To check if a cake is ready, insert a wooden skewer into the centre. It is ready if the skewer comes out clean, without dough or crumbs sticking to it.



Shelf level

The shelf level on which you place your food for baking depends on the oven function and number of trays being used.

- **Fan plus** 
1 tray: level 2
2 trays: levels 1+3/2+4
3 trays: levels 1+3+5

When using the universal tray and baking tray to bake on two or more levels at the same time, place the universal tray underneath the baking tray.

















Bake moist biscuits and cakes on a maximum of two levels at the same time.

- **Moisture Plus** 
1 tray: level 2
- **Intensive bake** 
1 tray: level 1 or 2
- **Conventional heat** 
1 tray: level 1 or 2



Baking

Baking charts

Creamed mixture

Cakes / biscuits		 [°C]	 5 1	 [min]
Muffins (1 tray)		140-150	2	35-45
		150-160	2	30-40
Muffins (2 trays)		140-150	2+4	35-45²⁾
Small cakes (1 tray) **		150	2	25-40
		160¹⁾	3	20-30
Small cakes (2 trays) **		150¹⁾	2+4	25-35
Small cakes/biscuits (1 tray)		140-150	2	25-35
		150-160 ¹⁾	3	15-25
Small cakes/biscuits (2 trays)		140-150	2+4	25-35²⁾
Sponge cake		150-160	2	60-70
		150-160¹⁾	2	60-70
Ring cake		150-160	2	50-60
		170-180	2	55-65

















 Function /  Fan plus /  Conventional heat



 Temperature /  Shelf level /  Duration



* The settings also apply for testing in accordance with EN 60350-1.

- 1) Pre-heat the oven. Do not use Rapid heat-up .
- 2) Take the baking trays out of the oven early if the food is sufficiently browned before the specified duration has elapsed.

Creamed mixture

Cakes / biscuits		 [°C]	 ⁵ ₁	 [min]
Foam cake (tray)		150-160	2	25-35
		150-160 ¹⁾	2	30-40
Marble, nut cake (tin)		150-160	2	55-75
		150-160	2	55-75
Fresh fruit cake, with meringue topping (tray)		150-160	2	40-50
		170-180	2	45-55
Fresh fruit cake (tray)		150-160	2	35-45
		160-170	2	35-55
Fresh fruit cake (tin)		150-160	2	55-65
		170-180 ¹⁾	2	35-45
Flan base		150-160	2	25-35
		170-180 ¹⁾	2	15-25

















 Function /  Fan plus /  Conventional heat

 Temperature / ⁵₁ Shelf level /  Duration



1) Pre-heat the oven. Do not use Rapid heat-up .

Baking

Rubbed in mixture

Cakes / biscuits		 [°C]	 ⁵ ₁	 [min]
Small cakes/biscuits (1 tray)		140-150	2	20-30
		160-170 ¹⁾	3	15-25
Small cakes/biscuits (2 trays)		140-150	1+3	20-30²⁾
Drop cookies (1 tray) *		140	2	30-40
		160¹⁾	3	20-30
Drop cookies (2 trays) *		140	1+3	35-45²⁾
Flan base		150-160	2	35-45
		170-180 ¹⁾	2	20-30
Streusel cake		150-160	2	45-55
		170-180	2	45-55
Cheese cake		150-160	2	80-95
		170-180	2	80-90
		150-160	2	80-90

 Function /  Fan plus /  Conventional heat /  Intensive bake















 Temperature / ⁵₁ Shelf level /  Duration

* The settings also apply for testing in accordance with EN 60350-1.



1) Pre-heat the oven. Do not use Rapid heat-up .

2) Take the baking trays out of the oven early if the food is sufficiently browned before the specified duration has elapsed.

Rubbed in mixture

Cakes / biscuits		 [°C]	 ⁵ 1	 [min]
Apple cake (Apple pie) (baking tin Ø 20 cm) *		160	2	90–100
		180	1	85–95
Apple pie		160–170	2	50–70
		170–180¹⁾	2	60–70
		160–170	2	50–70
Fresh fruit tart, glazed (tin)		150–160	2	55–75
		170–180	2	55–75
		150–160	2	55–65
Swiss apple pie (tray)		220–230¹⁾	1	30–50
		180–190	1	30–50

 Function /  Fan plus /  Conventional heat /  Intensive bake















 Temperature / ⁵ Shelf level /  Duration



* The settings also apply for testing in accordance with EN 60350-1.



1) Pre-heat the oven. Do not use Rapid heat-up .

Baking

Yeast mixtures and quark dough

















Cakes / biscuits		 [°C]	 ⁵ ₁	 [min]
Gugelhupf		150-160	2	50-60
		160-170	2	50-60
Stollen		150-160	2	45-65
		160-170	2	45-60
Streusel cake		150-160	2	35-45
		170-180	3	35-45
Fresh fruit cake (tray)		160-170	2	40-50
		170-180	3	50-60
Apple turnovers (1 tray)		150-160	2	25-30
		160-170	2¹⁾	25-30
Apple turnovers (2 trays)		150-160	1+3	25-30 ²⁾

 Function /  Fan plus /  Conventional heat



 Temperature /  ⁵₁ Shelf level /  Duration



- 1) For yeast dough. With quark dough use shelf level 3.
- 2) Take the baking trays out of the oven early if the food is sufficiently browned before the specified duration has elapsed.

Yeast mixtures and quark dough

Cakes / biscuits		 [°C]	 ⁵ ₁	 [min]
White bread		180-190	2	35-45
		190-200	2	30-40
Wholegrain bread		180-190	2	55-65
		200-210¹⁾	2	45-55
Pizza (tray)		170-180	2	30-45
		190-200¹⁾	2²⁾	30-45
		170-180	2²⁾	30-45
Onion tart		170-180	2	30-40
		180-190¹⁾	2	25-35
		170-180	2	30-40
Proving dough		35	³⁾	15-30
		35	³⁾	15-30













 Function /  Fan plus /  Conventional heat /  Intensive bake



 Temperature / ⁵₁ Shelf level /  Duration



- 1) Pre-heat the oven. Do not use Rapid heat-up .
- 2) For yeast dough. With quark dough use shelf level 3.
- 3) The dish can be placed on the oven floor. Depending on the size of the dish you may need to remove the shelf runners. If using Conventional heat  please also place the rack on on the oven floor.

Baking

Sponge mix

Cakes / biscuits		 [°C]	 ⁵ ₁	 [min]
Tart / flan base (2 eggs)		160-170	2	20-30
		160-170¹⁾	2	15-25
Sponge cake (4-6 eggs)		170-180	2	20-35
		150-160¹⁾	2	30-45
Whisked sponge *		180	2	20-30
		150-170¹⁾	2	20-45
Swiss roll		170-180 ¹⁾	2	15-20
		180-190¹⁾	2	15-20













 Function /  Fan plus /  Conventional heat



 Temperature / ⁵₁ Shelf level /  Duration



* The settings also apply for testing in accordance with EN 60350-1.

1) Pre-heat the oven. Do not use Rapid heat-up .

Choux pastry, puff pastry, meringue

Cakes / biscuits		 [°C]	 ⁵ ₁	 [min]
Choux buns (1 tray)		160–170	2	30–45
		180–190 ¹⁾	3	25–35
Choux buns (2 trays)		160–170	1+3	30–45²⁾
Puff pastry (1 tray)		170–180	2	20–30
		190–200	3	20–30
Puff pastry (2 trays)		170–180	1+3	20–30²⁾
Macaroons (1 tray)		120–130	2	25–50
		120–130 ¹⁾	3	25–45
Macaroons (2 trays)		120–130	1+3	25–50²⁾

 Function /  Fan plus /  Conventional heat



 Temperature / ⁵₁ Shelf level /  Duration

1) Pre-heat the oven. Do not use Rapid heat-up .

2) Take the baking trays out of the oven early if the food is sufficiently browned before the specified duration has elapsed.

Roasting

Functions

Depending on how the food is prepared, you can use Fan Plus , Moisture plus  or Conventional Heat .

Dishes

You can use any heat-resistant dishes:

Miele Gourmet oven dishes, roasting pans, ovenproof glass dishes, roasting bags, dishes made from earthenware or cast iron, the universal tray, rack and/or anti-splash insert (if available) on top of the universal tray.

We recommend roasting in oven dishes as this ensures that sufficient stock remains for making gravy. The oven also stays cleaner than when roasting on the rack.

Tips

- Browning: Browning only occurs towards the end of the roasting time. Remove the lid about halfway through the roasting time if a more intensive browning result is desired.
- Standing time: At the end of the programme, take the roast out of the oven, wrap in aluminium foil and leave to stand for about 10 minutes. This helps retain juices when the meat is carved.
- Roasting poultry: For a crisp skin, baste the poultry 10 minutes before the end of the cooking time with slightly salted water.



Notes on using the roasting charts

The data for the recommended function is printed in bold.

Unless otherwise stated, the durations given are for an oven which has not been pre-heated. With a pre-heated oven, shorten durations by up to 10 minutes.

Temperature

As a general rule, select the lower temperature given in the chart. If higher temperatures are used, the meat will brown on the outside, but will not be properly cooked through.

When cooking with Fan Plus  or Moisture plus , select a temperature 20 °C lower than for Conventional Heat .

For cuts which weigh more than 3 kg, select a temperature approx. 10 °C lower than that given in the roasting chart.

Roasting will take longer at the lower temperature, but will be more even.

When roasting on the rack, set a temperature approx. 10 °C lower than for roasting in an oven dish.

Pre-heating

Pre-heating is generally only required when roasting beef sirloin joints and fillet.

Roasting duration

The traditional British method for calculating the roasting time is to allow 15 to 20 minutes per lb/450 grammes, according to type of meat, plus approx. 20 minutes, adjusting the length of time as roasting proceeds to obtain the required result. The roasting time can also be determined by multiplying the thickness of the roast [cm] with the time per cm [min/cm], depending on the type of meat:

- Beef/venison: 15–18 min/cm
- Pork/veal/lamb: 12–15 min/cm
- Sirloin/fillet: 8–10 min/cm

Check if the meat is cooked after the shortest duration quoted.

















Shelf level ⁵₁









As a general rule, use shelf level 2.



Roasting

Roasting charts

















Beef, veal



Food		 [°C]	 ⁵ 1	 [min]	 ⁷⁾ [°C]
Topside of beef, approx. 1 kg		170–180	2	100–130 ⁵⁾	85–95
		190–200	2	110–140 ⁵⁾	
Fillet of beef approx. 1 kg ¹⁾		150–160 ⁴⁾	2	20–50	40–70 ⁸⁾
		150–160 ⁴⁾	2	20–50	
		180–190 ⁴⁾	2	20–50	
Sirloin joint, approx. 1 kg ¹⁾		150–160 ⁴⁾	2	30–60	40–70 ⁸⁾
		150–160 ⁴⁾	2	30–60	
		180–190 ⁴⁾	2	30–60	
Veal, approx. 1.5 kg		190–200	2	70–90 ⁵⁾	70–80
		190–200	2	70–90 ⁶⁾	
		200–210	2	70–90 ⁵⁾	

 Function /  Temperature /  ⁵ Shelf level /  Duration /  Core temperature
 Fan plus /  Moisture plus /  Conventional heat

- 1) Use the universal tray. First sear the meat all over on the hob to seal it.
- 2) If using Moisture plus , release a burst of steam at the beginning of the cooking programme.
- 3) If using Moisture plus , once the heating-up phase has finished, manually release the bursts of steam at intervals throughout the programme.
- 4) Pre-heat the oven. Do not use Rapid heat-up .
- 5) Roast with the lid on first, then remove the lid halfway through roasting and add approx. 0.5 l liquid.
- 6) Add approx. 0.5 l liquid halfway through roasting.
- 7) If you have a separate food probe you can use the core temperature shown.
- 8) Depending on required degree of doneness: rare: 40–45 °C, medium: 50–60 °C, well done: 60–70 °C

Pork

Food		 [°C]	 ⁵ ₁	 [min]	 ³⁾ [°C]
Pork joint, approx. 1 kg		160–170	2	100–120 ²⁾	80–90
	 ¹⁾	160–170	2	100–120 ²⁾	
		180–190	2	100–120²⁾	
Pork joint with crackling, approx. 2 kg		170–180	2	120–160 ²⁾	80–90
	 ¹⁾	180–190	2	120–160²⁾	
		190–200	2	130–160 ²⁾	
Gammon joint, approx. 1 kg		150–160	2	60–80 ²⁾	75–80
	 ¹⁾	150–160	2	60–80	
		170–180	2	80–100 ²⁾	
Meat loaf, approx. 1 kg		170–180	2	60–70 ²⁾	80–85
		200–210	2	70–80²⁾	













 Function /  Temperature / ⁵₁ Shelf level /  Duration /  Core temperature

 Fan plus /  Moisture plus /  Conventional heat

- 1) If using Moisture plus ¹⁾, once the heating-up phase has finished, manually release the bursts of steam at intervals throughout the programme.
- 2) Add approx. 0.5 l liquid halfway through roasting.
- 3) If you have a separate food probe you can use the core temperature shown.

Roasting

Lamb, game

















Food		 [°C]	 ⁵	 [min]	 ⁵⁾ [°C]
Leg of lamb, approx. 1.5 kg		170–180	2	90–110 ³⁾	75–80
	 ¹⁾	170–180	2	90–110 ⁴⁾	
		180–190	2	90–110³⁾	
Saddle of lamb, approx. 1.5 kg		220–230 ²⁾	2	40–60 ⁴⁾	70–75
	 ¹⁾	220–230 ²⁾	2	40–60	
		230–240²⁾	3	40–60⁴⁾	
Venison, approx. 1 kg		200–210	2	80–100³⁾	80–90
		200–210	2	80–100 ³⁾	

 Function /  Temperature / ⁵ Shelf level /  Duration /  Core temperature

 Fan plus /  Moisture plus /  Conventional heat

- 1) If using Moisture plus , once the heating-up phase has finished, manually release the bursts of steam at intervals throughout the programme.
- 2) Pre-heat the oven.
- 3) Roast with the lid on first, then remove the lid halfway through roasting and add approx. 0.5 l liquid.
- 4) Add approx. 0.5 l liquid halfway through roasting.
- 5) If you have a separate food probe you can use the core temperature shown.

Poultry, fish

Food		 [°C]	 ⁵ ₁	 [min]	 ³⁾ [°C]
Poultry, 0.8–1 kg		180–190	2	60–70	85–90
		190–200	2	60–70	
Poultry, approx. 2 kg		180–190	2	100–120	85–95
		190–200	3	100–120	
Poultry, stuffed, approx. 2 kg		180–190	2	110–130	85–95
		190–200	3	110–130	
Poultry, approx. 4 kg		160–170	2	120–160²⁾	85–90
		180–190	2	120–160 ²⁾	
Fish, whole, approx. 1.5 kg		160–170	2	45–55	75–80
	 ¹⁾	160–170	2	45–55	
		180–190	2	45–55	

 Function /  Temperature / ⁵₁ Shelf level /  Duration /  Core temperature

 Fan plus /  Moisture plus /  Conventional heat

- 1) If using Moisture plus , once the heating-up phase has finished, manually release the bursts of steam at intervals throughout the programme.
- 2) Add approx. 0.5 l liquid halfway through roasting.
- 3) If you have a separate food probe you can use the core temperature shown.

Low temperature cooking

This method is ideal for cooking beef, pork, veal or lamb when a tender result is required.

First sear the meat all over at a high temperature on the hob in order to seal it.

Then place the meat in the pre-heated oven where the low temperature and long cooking duration will cook it to perfection and ensure it is very tender.

The meat will relax and the juices inside will start to circulate evenly throughout the meat to reach the outer layers. This will give very tender and succulent results.

Tips

- Use lean meat which has been correctly hung and trimmed. Bones should be removed before cooking.
- For searing, use a suitable cooking oil or fat that can withstand high temperatures (e.g. clarified butter, vegetable oil).
- Do not cover meat during cooking.

Cooking takes between 2-4 hours depending on the size and weight of the meat and on how well cooked you want it as well as the level of browning required.

Procedure

Use the universal tray with the rack placed on top of it.

Do not use the Rapid Heat-up  function to pre-heat the oven.

- Place the rack together with the universal tray on shelf level 2.
- Select Conventional heat  and a temperature of 130 °C.
- Pre-heat the oven together with the universal tray and rack for approx. 15 minutes.
- Whilst the oven is pre-heating, sear the meat thoroughly on the hob.

 Danger of burning.

Wear oven gloves when placing hot food in the oven or removing it and when adjusting oven shelves etc. in a hot oven

- Place the seared meat on the rack.
- Reduce the temperature to 100 °C.
- Continue cooking until the end of the cooking duration.



You can set this procedure to finish automatically (see “Operation - entering a cooking duration”).

Low temperature cooking

After cooking

- Meat can be carved straight from the oven. It does not need to rest.
- The cooking result will not be affected if the meat is left in the oven after the programme has finished. It can be kept warm until you serve it.
- The meat is an ideal temperature to eat straight away. Serve on pre-heated plates with very hot sauce or gravy to prevent it cooling down too quickly.

Cooking duration / Core temperatures

Meat	 [min]	 [°C]
Fillet of beef	80–100	59
Sirloin joint		
– Rare	50–70	48
– Medium	100–130	57
– Well done	160–190	69
Pork fillet	80–100	63
Gammon *	140–170	68
Fillet of veal	80–100	60
Saddle of veal *	100–130	63
Saddle of lamb *	50–80	60

 Duration

 Core temperature

If you have a separate food probe, you can use the core temperature shown.

* Off the bone

Grilling



Danger of burning.

Grill with the oven door closed. If you grill with the door open, hot air will escape from the oven instead of being cooled by the cooling fan. The controls will get hot.

Functions

Grill

For grilling larger quantities of thin cuts (e.g. steaks) and browning baked dishes.

The whole of the top heating / grill element will get hot and glow red.

Fan grill

For grilling larger items, e.g. rolled meat, poultry.

The top heating / grill element and the fan switch on and off alternately.

Trays and racks

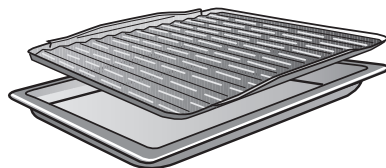
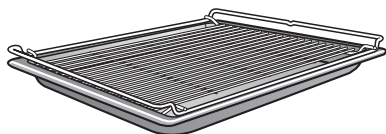

Use the universal tray with the rack or anti-splash insert (if available) on top. The juices from the food being cooked collect under the insert. This prevents them from spitting and making the oven dirty. The juices can then be used for making gravy and sauces.

Do not use the baking tray.

Preparing food for grilling

Trim the meat. Do not season meat with salt before grilling as this draws the juices out.

Add a little oil to lean meat if necessary. Do not use other types of fat as they can burn and cause smoke.

Clean fish in the normal way. To enhance the flavour, add a little salt or squeeze a little lemon juice over the fish.

Grilling

- Place the rack or the anti-splash insert (if available) in the universal tray.
- Place the food on top.
- Select the required oven function and the temperature.
- Pre-heat the grill for approx. 5 minutes with the door closed.



Danger of burning.

Wear oven gloves when placing hot food in the oven or removing it and when adjusting oven shelves etc. in a hot oven

- Place the food on the appropriate shelf level (see the Grilling chart).
- Close the door.
- Turn the food halfway through grilling.

Grilling

Notes on the grilling chart

The data for the recommended function is printed in bold.

Check the food after the shortest duration quoted.

Take note of the temperature range, the shelf levels and the durations. These take the size of the meat and cooking practices into account.

Temperature

As a general rule, select the lower temperature given in the chart. If higher temperatures are used, the meat will brown on the outside, but will not be properly cooked through.

Pre-heating

Pre-heating is essential for grilling. Always pre-heat the top heat/grill element for approx. 5 minutes with the door closed.

Shelf level

Select the shelf level according to the thickness of the food.

- Thin cuts: shelf level 3 or 4
- Thick cuts: shelf level 1 or 2

Grilling duration

- Thin pieces of fish and meat usually take 6–8 minutes per side. Thicker pieces require more time for each side. It is best to grill food of a similar thickness at the same time so that the grilling time for each item does not vary too greatly.
- Turn the food halfway through grilling.

Testing to see if cooked

One way of finding out how well a piece of meat has been cooked is to press down on it with a spoon:







- | | |
|------------|--|
| Rare: | If the meat gives easily to the pressure of the spoon, it will still be red on the inside. |
| Medium: | If there is some resistance, the inside will be pink. |
| Well-done: | If there is very little resistance, it is cooked through. |

Check if the meat is cooked after the shortest time quoted.

Tip: If the surface of thicker cuts of meat is cooked but the centre is not cooked, continue grilling at a lower temperature setting or use a lower shelf level to allow the food to cook through to the centre.

Grilling chart

Pre-heat the grill for approx. 5 minutes with the door closed.

Food to be grilled	 5 1				
		 [°C]	 [min]	 [°C]	 [min]
Thin cuts					
Steak	4/5	300	10–17	260	10–17
Burgers *	4	300	12–24	–	–
Kebabs	4	220	12–17	220	12–17
Chicken kebabs	4	220	12–17	220	12–17
Pork chops	4	275	16–24	240	13–22
Liver	3	220	8–12	220	8–12
Burgers	4	275	10–20	240	17–22
Bratwurst	3	220	8–15	220	10–17
Fish fillet	4	220	15–25	220	15–22
Trout	4	220	15–25	220	15–22
Toast *	3	300²⁾	5–8	–	–
Cheese toast	3	220	8–12	220	8–12
Tomatoes	3	220	6–10	220	8–12
Peaches	2/3	275	5–10	220	5–10
Thicker cuts					
Chicken, approx. 1.2 kg	1 ¹⁾	220	60–70	190	55–65
Pork, approx. 1 kg	2	–	–	180	80–90

 Grill /  Fan grill

 5 Shelf level /  Temperature /  Duration

* The settings also apply when using the Full grill  function for testing in accordance with EN 60350-1.

1) Use shelf level 2 for Fan grill .

2) Do not pre-heat the grill.

Special applications

Defrost

Use Fan plus  without setting the temperature for gently defrosting food.

The fan will switch on and circulate air at room temperature around the oven cavity.

 **Danger of salmonella poisoning.** It is particularly important to observe food hygiene rules when defrosting poultry. Do not use the liquid from the defrosted poultry. Pour it away, and wash the tray, the sink and your hands.

Tips

- Where possible, remove the packaging and put the food to be defrosted on the universal tray or into a suitable dish.
- When defrosting poultry, put it on the rack over the universal tray to catch the defrosted liquid so that the meat is not lying in this liquid.
- Fish does not need to be fully defrosted before cooking. Defrost so that the surface is sufficiently thawed to take herbs and seasoning.

Defrosting durations

The duration needed for defrosting depends on the type and weight of the food.

Frozen food	 [g]	 [min]
Chicken	800	90-120
Meat	500	60-90
	1000	90-120
Bratwurst	500	30-50
Fish	1000	60-90
Strawberries	300	30-40
Butter cake	500	20-30
Bread	500	30-50

 weight /  defrosting duration



Drying food





Drying is a traditional method of preserving fruit, certain vegetables and herbs.

It is important that fruit and vegetables are ripe and not bruised before they are dried.

- Prepare the food for drying
 - Peel and core apples, and cut into slices 0.5 cm thick.
 - Stone plums, if necessary.
 - Peel, core and cut pears into thick wedges.
 - Peel and slice bananas.
 - Clean mushrooms and cut them in half or slice them.
 - Remove parsley and dill from the stem.
- Distribute the food evenly over the universal tray.

Use the Gourmet perforated baking tray, if you have one.

- Select Fan plus  or Conventional heat .
- Select a temperature of 80–100 °C.
- Place the universal tray on shelf level 2.
With Fan plus  you can dry produce on levels 1+3 at the same time.

Food		 [min]
Fruit		120–480
Vegetables		180–480
Herbs		50–60

-  Function /  Drying time
 Fan plus /  Conventional heat

- Reduce the temperature if condensation begins to form in the oven.

 Danger of burning. Wear oven gloves when removing the dried food from the oven.

- Allow the dried fruit or vegetables to cool down after drying.

Dried fruit must be completely dry, but also soft and elastic.

- Store in sealed glass jars or tins.

Special applications

Gentle bake

Gentle bake is suitable for small amounts e.g. of frozen pizza, bake-off rolls, cookies and for meat dishes and roasts. The optimum use of heat enables savings of up to 30 % energy to be made compared to cooking with a standard oven function with comparably good cooking results.

The temperature can be set between 100 and 250 °C.

This function is not suitable for larger amounts of food such as sponge cakes and fresh fruit cake where the cake mix needs to be thoroughly baked throughout as no energy savings would be made.

For optimum results keep the door shut whilst cooking.

Examples of use:

Food	🌡️ [°C]	🕒 [min]
Biscuits	150	25–30
Ratatouille	180	40–60
Fish fillet in foil approx. 500 g	200	25–30
Frozen pizza, pre-cooked	200	20–25
Ham roast, approx. 1.5 kg	160	130–160
Braised beef, approx. 1.5 kg	180	160–180

🌡️ Temperature / 🕒 Duration

- Use shelf level 1 or 2 depending on the height of the food.
- The durations given are for an oven which has not been pre-heated.
- Roast with the lid on first, then remove the lid three-quarters of the way through roasting and add approx. 0.5 l liquid.
- Check the food after the shortest duration quoted.

Frozen food/Ready meals

Tips

Cakes, pizza, baguettes

- Large frozen items such as cakes, pizzas or baguettes cover an extensive area of the baking tray or universal tray.
The temperature difference if large frozen items are cooked in these trays can cause the tray to distort in such a way that it cannot be removed from the oven when it is hot. Further use will make the distortion worse. Place this type of food on baking parchment on the rack to prevent the risk of this happening.
- Use the lowest temperature recommended on the manufacturer's packaging.

Oven chips, croquettes or similar items

- Small items of frozen food such as oven chips can be cooked on the baking tray or universal tray.
Place baking parchment on the tray so that they cook gently.
- Use the lowest temperature recommended on the manufacturer's packaging.
- Turn several times during cooking.

Method

Eating food which has been cooked correctly is important for good health.

Only bake cakes, pizza, chips etc. until they are golden. Do not overcook them.

- Select the function and temperature recommended on the manufacturer's packaging.
- Pre-heat the oven.
- Place the food in the pre-heated oven on the shelf level recommended on the packaging.
- Check the food at the end of the shortest duration recommended on the packaging.

Special applications

Heat crockery

Use Fan plus  for pre-heating crockery.

Only pre-heat heat-resistant dishes.

- Place the rack on shelf level 2 and place the crockery on it. Depending on the size of the crockery you can also use the oven floor and also take the side runners out to make more room.
- Select Fan plus .
- Set the temperature to 50–80 °C.



Danger of burning.

Wear oven gloves when removing the dishes from the oven. Droplets of water may have accumulated underneath the dish.

- Remove the heated crockery from the oven.



Danger of burning.

Make sure the oven heating elements are switched off and that the oven cavity is cool.



Danger of injury.

The steam from a steam cleaning appliance could reach electrical components and cause a short circuit.

Do not use a steam cleaner to clean the oven.

All surfaces can become discoloured or damaged if unsuitable cleaning agents are used. The front of the oven, in particular, will be damaged by oven cleaners.

All surfaces are susceptible to scratching. Scratches on glass surfaces could cause a breakage in certain circumstances.

Remove any residual cleaning agent immediately.

Unsuitable cleaning agents

To avoid damaging the surfaces, do not use:

- cleaning agents containing soda, ammonia, acids or chlorides
- cleaning agents containing descaling agents on the oven front
- abrasive cleaning agents, e.g. powder cleaners and cream cleaners
- solvent-based cleaning agents
- stainless steel cleaning agents
- dishwasher cleaner
- glass cleaning agents
- cleaning agents for ceramic hobs
- hard, abrasive brushes or sponges, e.g. pot scourers, brushes or sponges which have been previously used with abrasive cleaning agents
- melamine eraser blocks
- sharp metal scrapers
- wire wool
- spot cleaning
- oven cleaner
- stainless steel spiral pads

Cleaning and care

If soiling is left on for any length of time, it may become impossible to remove. If items are used frequently without being cleaned, it may become very difficult to clean them.

Soiling is best removed after each use of the oven.

The accessories are not dishwasher-proof.

Tips

- Soiling caused by spilt juices and cake mixtures is best removed whilst the oven is still warm. Exercise caution and make sure the oven is not too hot - danger of burning.
- To make manual cleaning easier you can dismantle the oven door, remove the side runners and the FlexiClip runners (if present) and lower the top heating/grill element.

Normal soiling

The fibre glass seal around the front of the oven should be handled carefully. Do not rub and scour it. If possible you should avoid trying to clean it.

- It is best to remove normal soiling immediately using a clean sponge and a solution of hot water and washing-up liquid or with a clean, damp microfibre cloth.
- After cleaning make sure all residual cleaning agent is thoroughly removed with clean water. This is particularly important when cleaning PerfectClean surfaces as cleaning agent residues can impair the non-stick properties.
- After cleaning, wipe the surfaces dry using a soft cloth.

Stubborn soiling (excluding the FlexiClip runners)

Spilt fruit and roasting juices may cause lasting discolouration or matt patches on enamelled surfaces. This discolouration is permanent but will not affect the efficiency of the finish. Do not attempt to remove these marks. Clean these following the instructions given here.

- Baked on deposits can be removed with a glass scraper or with a non-abrasive stainless steel spiral pad, warm water and washing-up liquid.
- Very stubborn soiling on PerfectClean surfaces can be cleaned using Miele Oven Cleaner. This cleaner must only be applied to cold surfaces. Follow the instructions on the packaging

Non-Miele oven cleaner must only be used in a cold oven and for no longer than a maximum of 10 minutes.

- You can then also use the scouring pad on the back of a washing-up sponge to remove the soiling.
- After cleaning, remove all oven cleaning agent residues thoroughly with clean water, and dry with a soft cloth.

Cleaning and care

Pyrolytic cleaning of the oven interior

Instead of cleaning the oven manually you can run the Pyrolytic cleaning programme .

The Pyrolytic programme heats the oven cavity to over 400 °C. Any residual soiling is burnt off and turned to ash by the high temperatures.

This oven has three levels of pyrolytic cleaning, each with a different duration. Select:

- Level 1 for light soiling
- Level 2 for heavier soiling
- Level 3 for very heavy soiling

For safety reasons the oven door is automatically locked at the beginning of the pyrolytic cleaning process. It cannot be opened until after the programme has finished.

The timer can be used to delay the start time of the Pyrolytic cleaning programme, for instance to make use of cheaper electricity tariffs.

At the end of the Pyrolytic cleaning programme any residues such as ash from the pyrolytic process can be easily wiped away.

Setting up for pyrolytic cleaning

The high temperatures used during pyrolytic cleaning will damage accessories that are not designed for pyrolytic cleaning.

Please remove these accessories from the oven interior before starting pyrolytic cleaning. This also applies to non-pyrolytic accessories purchased separately to the oven.

The following accessories are suitable for pyrolytic cleaning and can be left in the oven:

- Side runners
- FlexiClip telescopic runners HFC 72
- Rack HBBR 72
- Take all non-pyrolytic accessories out of the oven.
- Place the rack on the top shelf level.

Coarse soiling in the oven compartment can cause an accumulation of smoke which can lead to the pyrolytic cleaning programme switching off. Burnt on residues can leave discolouration or matt areas on enamelled surfaces.

- Before running the pyrolytic cleaning programme, remove coarse soiling from the oven compartment and loosen any burnt on residues with a scraper suitable for use on glass.

Starting Pyrolytic cleaning



Danger of burning!

The oven door gets much hotter during pyrolytic operation than during normal use.

Prevent children from touching the oven during pyrolytic cleaning.

- Select Pyrolytic  cleaning.



PY 1 appears in the display. The number flashes.

Use the rotary selector < > to select between *PY 1*, *PY 2* and *PY 3*.

- Select the level required.
- Confirm with *OK*.

Pyrolytic cleaning will now start.

 will also appear in the display.





 will flash until the door is locked.

The oven heating and the cooling fan will then switch on automatically.

The oven lighting will not come on during the Pyrolytic cleaning programme.

If you want to see how the Pyrolytic cleaning programme is progressing you need to highlight the duration symbol  in the display.

- Select **≡*.
- If necessary use the rotary selector < > to move the triangle  under .

The time remaining for the Pyrolytic cleaning programme will appear in the display. You cannot alter the duration.

If you have set the timer a tone will sound when the duration has elapsed,  will flash and the time will start to count upwards. Once you press *OK*, the audible and visual signals will turn off. *PY* and the number of the pyrolytic cleaning level chosen will reappear.

Cleaning and care

To delay the start time of the Pyrolytic cleaning programme

Start the programme as described above and then set the required finish time within the first five minutes of starting the programme.

- Select '≡.
- Use the rotary selector < > to move triangle ▲ until it appears under ⌚.
- :- - will appear.
- Confirm with OK.

When you turn the rotary selector < > clockwise, the finish time will appear in the display. This is calculated from the actual time of day plus the duration of your selected pyrolytic cleaning programme.

- Use the rotary selector < > to select the required finish time.
- Confirm with OK.

The finish time is now set and has been saved to memory.



The oven heating will now switch off.



The finish time can be changed at any time up until the start time for the programme.

As soon as the start time is reached, the oven heating and the cooling fan will switch on. The duration will show in the display.



At the end of pyrolytic cleaning



0:00,  and  will appear in the display.

The door is locked as long as the  symbol is lit up. The  symbol will start flashing as soon as the door lock has been released.

When the door lock has been released:

-  will go out.
 -  will flash.
 - A buzzer will sound if the buzzer is switched on (see “Settings – P 2”).
- Turn the function selector to ●.

The visual and acoustic signals are switched off.

 Danger of burning.
Wait until the oven has cooled down before removing residual soiling left in the oven compartment from pyrolytic cleaning.

- Wipe any residues (e.g. ash) left behind after the Pyrolytic cleaning programme out of the oven compartment and wipe any residues off any pyrolytic accessories. The amount of ash will vary depending on how dirty the oven was.

Most soiling can be easily removed using a clean, damp microfibre cloth, or with hot water and a little washing-up liquid on a clean sponge.



Depending on how dirty the oven was there may be a visible layer of soiling across the inner glass pane on the door. This should be removed using the reverse of a non-scouring washing-up sponge or with a stainless steel spiral pad and a little washing-up liquid.

- Extend and retract the FlexiClip telescopic runners several times after running the Pyrolytic cleaning programme.







Please note:

- The fibre glass seal around the front of the oven should be handled carefully. Do not rub and scour it. If possible you should avoid trying to clean it.
- After pyrolytic cleaning the FlexiClip telescopic runners may appear discoloured or a lighter colour in some places. This will not affect the functioning of the runners in any way.
- Spilt fruit juices may cause lasting discolouration to enamelled surfaces. This discolouration is permanent but will not affect the efficiency of the enamel. Do not attempt to remove these marks.

If pyrolytic cleaning is cancelled

If the Pyrolytic cleaning programme is cancelled the oven door will remain locked until the temperature inside the oven drops to below 280 °C. The  symbol will light up until the temperature has dropped below this level. The door can be opened as soon as the  symbol starts flashing.

The following will cause the Pyrolytic cleaning programme to stop:

- Turning the function selector to •.
Once the door has been unlocked,  will go out and the time of day will reappear in the display. If necessary start the Pyrolytic cleaning programme again.
- Turning the function selector to a different function.
Py and  will appear in the display. Once the door has been unlocked,  will go out and *Py* will start to flash.
- A power cut.
Py and  will appear in the display. Once the door has been unlocked,  will go out and *Py* will start to flash.
When power is restored *Py* will light up until the temperature in the oven has dropped below 280 °C.  will then appear in the display. The door lock releases and the time of day reappears.

Cleaning and care

Removing the door

The door weighs approx. 10 kg.

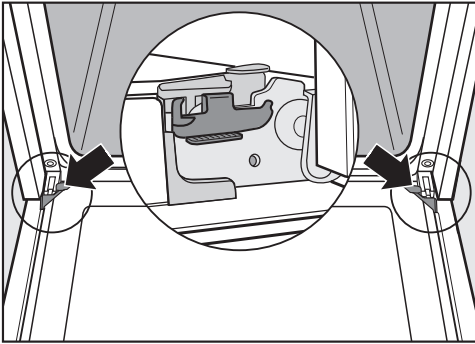

The door is connected to each door hinge by retainers. Before the door can be removed the locking clamps on both hinges must first be unlocked.

- Open the door fully.

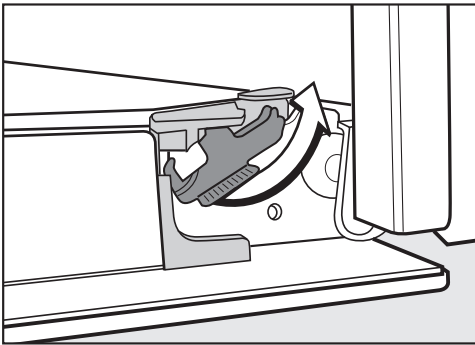

- Release the locking clamps by turning them as far as they will go.

Do not attempt to take the door off the retainers when it is in the horizontal position as the retainers will spring back against the oven.

Do not use the handle to pull the door off the retainers as the handle could break.

- Raise the door up till it rests open.



- Holding the door securely at both sides lift it upwards off the retainers. Make sure you take it off straight.

Dismantling the door

The oven door is an open system with 4 glass panes which have a heat-reflective coating on some of their surface.

When the oven is operating, air is directed through the door to keep the outer pane cool.

If soiling has worked its way in between the glass panes, the door can be dismantled in order to clean in between the panes.

Take particular care as scratches can damage the glass. When cleaning the glass panes do not use abrasive cleaning agents, hard sponges or brushes and do not use sharp metal tools or scrapers.

Please also read the general notes on cleaning the oven front before cleaning the glass panes.

The glass panes are coated in different ways with a heat-reflective coating on the sides facing into the oven cavity. The glass panes must be fitted the right way round after being cleaned.

Oven spray will damage the aluminium trims inside the door. These should only be cleaned using hot water and washing-up liquid applied with a clean sponge or a clean, damp microfibre cloth.

Be especially vigilant after dismantling the door that the glass panes do not break.

Cleaning and care

 **Danger of injury.**
Always remove the door before disassembling it.

- Place the door on a protective surface (e.g. on a tea towel) with the outside pane facing downwards to prevent it getting scratched. The door handle should line up with the edge of the table so that the glass lies flat and does not get broken during cleaning.

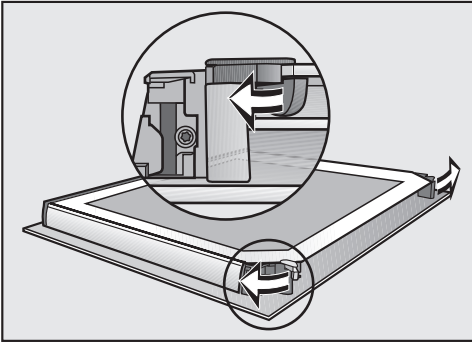

- Flip the two glass pane retainers outwards to open them.

You can now remove the inner panes and the two middle panes one after the other.

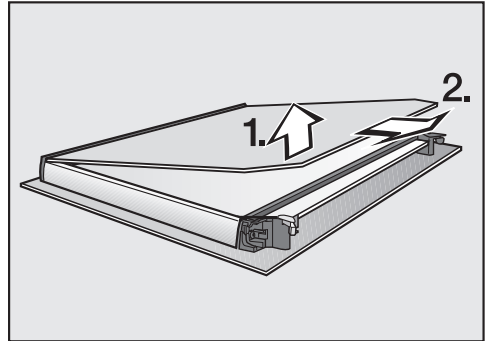

- **Carefully** lift the inner pane up and out of the plastic strip.

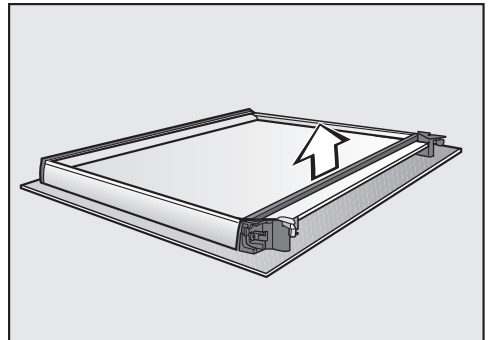

- Remove the seal.

Cleaning and care

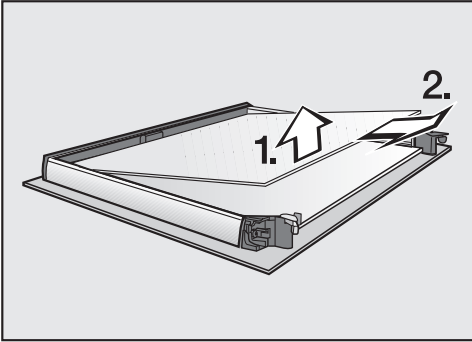

- Carefully lift the top of the two middle panes up and take it out.

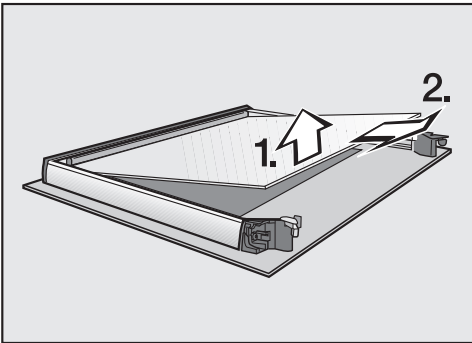

- Then lift the bottom of the two middle panes up carefully and take it out.
- Clean the door panes and other parts with a clean sponge and a solution of hot water and washing-up liquid or a clean damp microfibre cloth.
- Dry all parts with a soft cloth.

Then reassemble the door carefully:

The two middle panes are identical. To help you put them back in correctly the material number is printed on the panes.

- Refit the lower of the two middle panes in such a way that the material number is legible (not a mirror image).

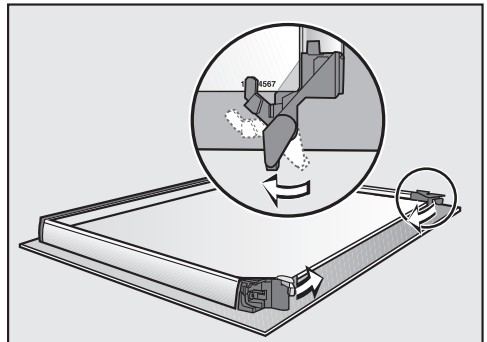

- Flip both the glass pane retainers inwards in such a way that they fit over the lower of the two middle panes.
- Then refit the upper of the middle two panes in such a way that the material number is legible (not a mirror image). The glass pane should lie on top of the retainers.

Cleaning and care

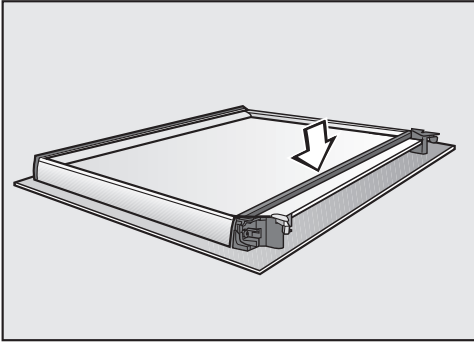

- Refit the seal.

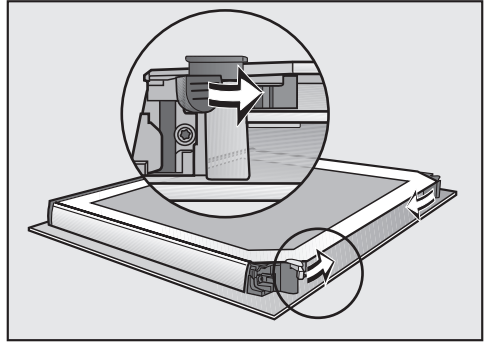

- Flip both the glass pane retainers inwards to close them.

The door is now reassembled and is ready to fit back on the oven.

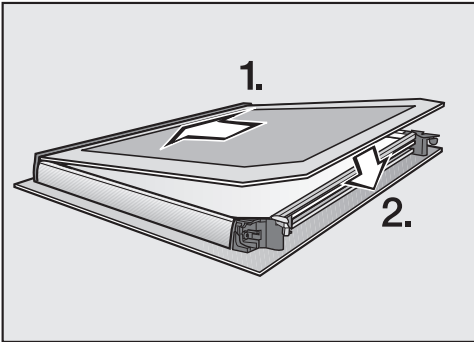

- Push the inner pane with the matt printed side facing downwards into the plastic strip and place it between the retainers.

Refitting the door

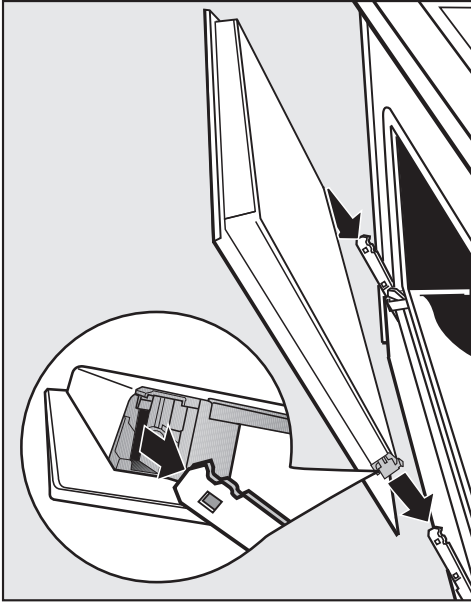

- Hold the door securely on both sides and carefully fit it back into the hinge retainers. Make sure that the door goes back on straight.

- Open the door fully.

If the locking clamps are not locked, the door could work loose resulting in damage.

Ensure that the locking clamps are locked after refitting the door.

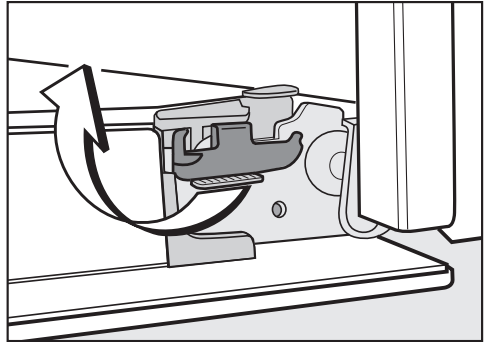

- Flip both locking clamps back up as far as they will go into a horizontal position.

Cleaning and care

Removing the side runners with FlexiClip runners

You can remove the side runners together with the FlexiClip runners (if present).

If you wish to remove the FlexiClip runners separately beforehand, please follow the instructions in “Features – Fitting and removing FlexiClip telescopic runners”.

 Danger of burning.
Make sure the oven heating elements are switched off and cool.

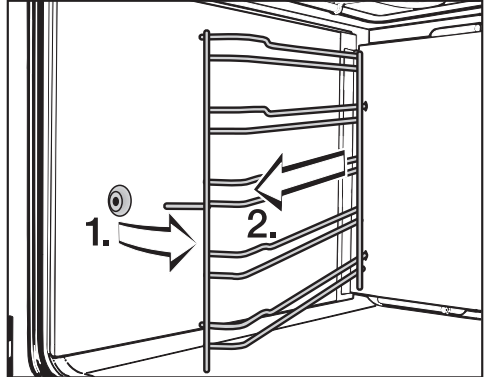

- Pull the side runners out of holder (1) at the front of the oven and then pull them out of the oven (2).

Refit in the reverse order.

- Take care and ensure that all parts are correctly fitted.

Lowering the top heat/grill element

 Danger of burning.

Make sure the oven heating elements are switched off and that the oven cavity is cool.

- Remove the side runners.

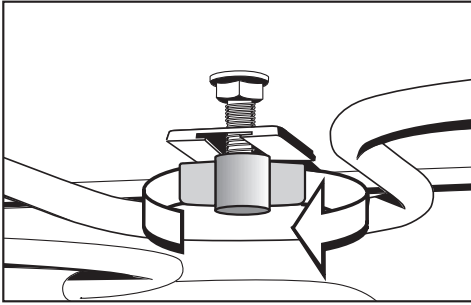

- Undo the wing nut.

Use caution not to damage the top heat/grill element.

Do not use force when lowering the top heat/grill element.

- Carefully lower the top heat/grill element.

You can now clean the roof of the oven.

- Raise the top heat/grill element and tighten the wing nut securely.
- Refit the side runners.

Cleaning and care

Descaling the steam injection system

When to run the descaling process

The frequency of descaling will depend on the water hardness level in your area.

The descaling process can be run at any time.

However, to ensure that the oven functions correctly you will be automatically prompted to run the descaling process after a certain number of programmes.



If Moisture plus  is selected, a prompt to run the descaling process will appear in the display.



You can use the Moisture plus  function 10 more times before descaling. After the 10th programme, the function will be locked and cannot be used until descaling is carried out.

The prompt will disappear after a few seconds. You can also dismiss it by touching *OK*.

All other modes can still be used.

The number of cooking processes available until the function locks out will count down in the display until  0 and  appear.



After that the Moisture plus function  is locked and can only be used again after the descaling process has been run.

Sequence of a descaling cycle

Once the descaling process has been started it must be completed through to the end. It cannot be cancelled.

The descaling cycle takes approx. 90 minutes and consists of several steps:

- E 0* Drawing in the descaling solution
- E 1* Activation phase
- E 2* Rinse 1
- E 3* Rinse 2
- E 4* Rinse 3
- E 5* Residual water evaporation

Preparation

You will need a container of approx. 1 litre capacity.

A plastic tube (with suction cup) is supplied with your oven so that you do not have to hold the container with the descaling agent underneath the water intake pipe.

We recommend using the descaling tablets supplied. They have been specially developed for Miele for optimum results.

Other descaling agents, which contain other acids besides citric acid and/or other undesirable substances, such as chlorides for example, could cause damage. Moreover, the descaling result required could not be guaranteed if the descaling solution was not of the appropriate concentration.

Tip: Miele descaling tablets are available to order from the Miele webshop, from Miele or from your Miele dealer.

- Fill the container with approx. 600 ml of cold tap water and thoroughly dissolve one descaling tablet in it.

Follow the instructions for the mixing ratio carefully. Otherwise the oven will be damaged.

- Place the end of the plastic tube in the bottom of the container and secure the tube with the suction cup.
- Place the universal tray on the top shelf level to collect the descaling solution after it has been used.

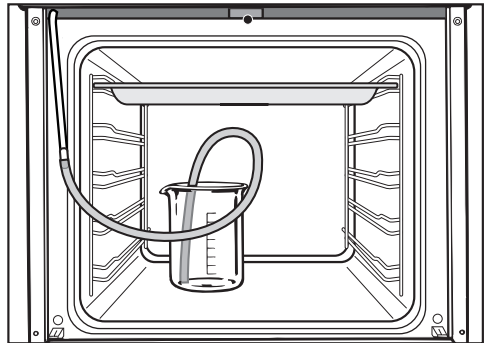

- Place the container with the descaling solution on the floor of the oven. Secure the other end of the plastic tube to the water intake pipe.

Cleaning and care

Carrying out the descaling process

As soon as the intake process $E \bar{D}$ has started the descaling process can no longer be cancelled.

- Select the Moisture plus $\Delta \bar{D}$ function.
- Use the rotary selector $< >$ to select E .
- Confirm with OK .

If Moisture plus $\Delta \bar{D}$ was already locked, the descaling process can be started immediately by touching OK .

The prompt for the **drawing in process** ($E \bar{D}$) will appear and the triangle \blacktriangle will flash under $\Delta \bar{D}$



- Confirm with OK .

The intake process will begin. You can hear the pump while this is happening.

The amount of solution specified can be more than the amount which is actually taken in. Some of the solution may therefore be left in the container at the end of descaling.

The **activation phase** ($E \bar{I}$) will begin. You can follow the duration as it counts down.



- Leave the container with the tube connected to the water intake pipe in the oven. Top the container up with approx. 300 ml of water, as the system will need to draw in some more liquid during the activation phase.

The system will take in more liquid at approximately 5 minute intervals. You will hear the noise of the pump for a moment or so.

The descaling step can be displayed:

- Select $\bar{\equiv}$.
- Use the rotary selector $< >$ to move the triangle \blacktriangle until it lights up under $\bar{\equiv}$.



- To display time remaining, use the rotary selector \blacktriangle to move the triangle $< >$ until it lights up under $\bar{\equiv}$.

At the end of the activation phase a buzzer will sound, if the buzzer is switched on (see "Settings - $P \bar{2}$ ").

At the end of the activation phase the steam injection system will need to be cleaned to remove all traces of descaling solution.

Cleaning is carried out by flushing approx. 1 litre of fresh tap water through the system. The water is collected in the universal tray. This process is repeated three times.

- Take the universal tray out of the oven and empty it. Place the tray back in the oven again on the top shelf level.
- Detach the plastic tube from the container.
- Rinse the container and fill with approx. 1 litre of fresh tap water.
- Place the container back in the oven, insert the plastic tube, secure it to the container and close the door.
- Confirm with *OK*.

The intake process for the **first rinse** (E 2) starts.

Water will be flushed through the steam injection system and will then collect in the universal tray.

- Take the universal tray out of the oven and empty it. Place the tray back in the oven again on the top shelf level.
- Detach the plastic tube from the container. Fill it with approx. 1 litre of fresh tap water.
- Place the container back in the oven, insert the plastic tube, secure it to the container and close the door.
- Confirm with *OK*.

The intake process for the **second rinse** (E 3) starts.

- Repeat the last four steps.

The intake for the **third rinse** (E 4) starts.

Leave the universal tray (with the water which has collected in it) on the top oven shelf whilst the evaporation process takes place.

- Remove the container and tube from the oven.

Cleaning and care

- Close the door.

Start the **Evaporate residual moisture** process (E 5).

 Steam can cause scalding.
Do not open the door while the residual water is being evaporated.



- Confirm with **OK**.

The oven heating will switch on and the duration will count down in the display.



During the evaporation process, the duration may be adjusted by the system according to how much water is currently present.

The last minute will count down in seconds.

At the end of the evaporation process:

- 0:00 will appear.
-  will flash.
- A buzzer will sound if the buzzer is switched on (see “Settings – P 2”).



- Turn the function selector to ●.

 **Danger of burning.**
Allow the oven interior and accessories to cool down before cleaning them.



- Remove the universal tray and empty it. Clean the oven interior to remove any condensation and descaling agent residue.

Leave the oven door open until the oven interior is completely dry.



Problem solving guide

Many malfunctions and faults that can occur in daily operation can be easily remedied. Time and money will be saved because a service call will not be needed.











The following guide may help you to find the reason for a malfunction or a fault, and to correct it.

Problem	Cause and remedy
<p>The display is dark.</p>	<p>The time of day display is deactivated, so when the appliance is switched off, the time of day display is switched off.</p> <ul style="list-style-type: none"> ■ As soon as the oven is switched on, the time of day will appear. If you want it to be displayed constantly, the setting to switch the time of day display back on must be changed (see “Settings – P 1”).
	<p>There is no power to the oven.</p> <ul style="list-style-type: none"> ■ Check whether the mains fuse has tripped. If it has, contact a qualified electrician or Miele.
<p>A function has been selected and the time of day and the  symbol are still in the display.</p>	<p>The system lock  has been activated.</p> <ul style="list-style-type: none"> ■ Switch off the system lock (see “System lock ”).
<p>The oven does not heat up.</p>	<p>Demo mode has been activated. <i>nE5_</i> appears in the display. The oven can be operated but does not heat up.</p> <ul style="list-style-type: none"> ■ Deactivate demo mode (see “Settings – P 8”).

Problem solving guide

Problem	Cause and remedy
A function has been selected but the oven is not working.	<p>There has been a power cut which has caused a current process to stop.</p> <ul style="list-style-type: none"> ■ Turn the function selector to the • position and switch the oven off. Start the cooking process again.
12:00 has appeared in the display with the triangle ▲ flashing under .	<p>The power supply was interrupted for longer than 200 hours.</p> <ul style="list-style-type: none"> ■ Reset the time of day (see “Using for the first time”).
0:00 has appeared unexpectedly in the display and  is flashing at the same time. The buzzer might also be sounding.	<p>The oven has been operating for an unusually long time and this has activated the safety switch-off function.</p> <ul style="list-style-type: none"> ■ Turn the function selector to • and switch the oven off. The oven is now ready to use again immediately.
F 32 appears in the display.	<p>The door has not locked for the Pyrolytic cleaning programme.</p> <ul style="list-style-type: none"> ■ Turn the function selector to the • position and select the Pyrolytic programme you want again. If the problem persists, contact Miele Service.
F 33 appears in the display.	<p>The door has not unlocked after the Pyrolytic cleaning programme.</p> <ul style="list-style-type: none"> ■ Turn the function selector to the • position and turn the oven off. If the problem persists, contact Miele Service.
F XX appears in the display,	<p>There is a problem that you cannot resolve.</p> <ul style="list-style-type: none"> ■ Call Miele Service.

Problem solving guide

Problem	Cause and remedy
No water is being taken in with the Moisture plus  function.	Demo mode is activated. The oven can be operated but the pump for the steam injection system does not work. <ul style="list-style-type: none"> ■ Deactivate demo mode (see “Settings – P 8”).
	The pump for the steam injection system is faulty. <ul style="list-style-type: none"> ■ Call Miele Service.
 10 appears in the display.	Moisture plus  can only be used another ten times. The number of times it can be used will count down in the display until  0 and  appear. The descaling programme must then be run (see “Descaling the steam injection system  ”). All other functions can be used as normal.
 0 and  appear in the display	Moisture plus  cannot be used. <ul style="list-style-type: none"> ■ Carry out the descaling process (see “Descaling the steam injection system ”). All other functions can be used as normal.
A noise can be heard after a cooking process.	The cooling fan will continue to run for a while after the oven has been switched off to prevent any humidity building up in the oven, on the control panel or in the oven housing unit. This cooling fan will switch itself off automatically after a certain period of time.
The oven has switched itself off.	The oven will switch itself off automatically to save energy if no other action is taken within a certain time frame after switching it on or after the end of a cooking programme. <ul style="list-style-type: none"> ■ Switch the oven back on.
Cakes and biscuits are not sufficiently baked in the times given in the chart	A different temperature from the one given in the recipe was used. <ul style="list-style-type: none"> ■ Select the temperature required for the recipe.
	The ingredient quantities are different from those given in the recipe. <ul style="list-style-type: none"> ■ Double check the recipe. The addition of more liquid or more eggs makes a moister mix which would take longer to cook.

Problem solving guide

Problem	Cause and remedy
Browning is uneven.	<p>The wrong temperature or shelf level was selected.</p> <ul style="list-style-type: none"> ■ There will always be a slight unevenness. If the unevenness is pronounced, check that the correct temperature and shelf level have been selected.
	<p>The material or colour of the baking tin is not suitable for the oven function.</p> <ul style="list-style-type: none"> ■ When using Conventional heat  use matt, dark coloured tins. Light coloured, shiny pans will not produce as desirable results.
There is soiling in the oven after the Pyrolytic cleaning programme.	<p>The Pyrolytic cleaning programme burns off soiling in the oven and leaves it as ash.</p> <ul style="list-style-type: none"> ■ Remove the ash using warm water with a little washing-up liquid with a soft sponge or a clean, damp microfibre cloth. If coarse soiling remains, run the pyrolytic cleaning programme again. Select a longer duration if necessary.
The rack and other accessories make a noise when being pushed into or pulled out of the oven.	<p>The pyrolytic resistant surface of the side runners creates friction when accessories are being pushed into or pulled out of the oven.</p> <ul style="list-style-type: none"> ■ To reduce the friction, add a few drops of heat resistant cooking oil to some kitchen paper and use this to lubricate the side runners. Do this after every pyrolytic cleaning programme.
The oven lighting switches off after a short time.	<p>The oven lighting is set to switch off after 15 seconds (default setting). You can change the default setting for this (see “Settings - P 7”).</p>

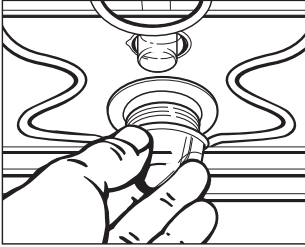
Problem	Cause and remedy
<p data-bbox="76 202 344 260">The top oven lighting does not turn on.</p> 	<p data-bbox="400 202 818 229">The halogen lamp needs replacing.</p> <div data-bbox="404 236 1046 363" style="border: 1px solid gray; padding: 5px;"><p data-bbox="418 248 687 284">⚠ Danger of burning. Make sure the oven heating elements are switched off and that the oven cavity is cool.</p></div> <ul data-bbox="400 387 1034 678" style="list-style-type: none"><li data-bbox="400 387 927 414">■ Disconnect the appliance from the mains.<li data-bbox="400 421 1016 512">■ Turn the lamp cover a quarter turn anti-clockwise to release it and then pull it together with its seal downwards to take it out.<li data-bbox="400 518 1034 579">■ Replace it with a new halogen lamp (Osram 66725 AM/A, 230 V, 25 W, G9).<li data-bbox="400 585 1034 646">■ Refit the lamp cover together with its seal and turn clockwise to secure.<li data-bbox="400 652 960 678">■ Reconnect the oven to the electricity supply.

Service

Contact in case of malfunction

In the event of any faults which you cannot remedy yourself, please contact your Miele Dealer or Miele Service.

Contact information for Miele Service can be found at the end of this document.

Please note that telephone calls may be monitored and recorded for training purposes and that a call-out charge will be applied to service visits where the problem could have been resolved as described in this booklet.

Please quote the model and serial number of your appliance when contacting Miele. This information can be found on the data plate.

This information is given on the data plate, visible on the front frame of the oven, with the door fully open.

Warranty

For information on the appliance warranty specific to your country please contact Miele. See back cover for address.

In the UK, your appliance warranty is valid for 2 years from the date of purchase. However, you must activate your cover by calling 0330 160 6640 or registering online at www.miele.co.uk.



Danger of injury!

Installation, repairs and other work by unqualified persons could be dangerous. Miele cannot be held liable for unauthorised work.

Connection to the electrical supply must be carried out by a suitably qualified and competent person in accordance with local and national safety regulations. Ensure power is not supplied to the appliance until after installation or repair work has been carried out.

Connection of this appliance to the electricity supply must be made in accordance with current safety regulations (BS 7671 in the UK).

Connection of this appliance should be made via a fused connection unit or a suitable isolator and the on/off switch should be easily accessible after the appliance has been built in.

If the switch is not accessible after installation (depending on country) an additional means of disconnection must be provided for all poles.

When switched off there must be an all-pole contact gap of 3 mm in the isolator switch (including switch, fuses and relays according to EN 60335).

Connection data

The required connection data are given on the data plate located on the oven trim visible when the door is open.

Ensure that these match the mains supply.

- When contacting Miele, please quote the following:
 - Model number
 - Serial number
 - Connection data (voltage/frequency/maximum connected load)

When replacing the cable supplied with another cable or changing the connection, only cable type H05VV-F with a suitable cross-sectional area (CSA) may be used.

Oven

This oven is supplied with an approx. 1.7 m long 3-core cable for connection to a 230 V, 50 Hz supply.

The wires in the mains lead are coloured as follows:

Green/yellow = earth

Blue = neutral

Brown = live



WARNING - THIS APPLIANCE MUST BE EARTHED

For extra safety it is advisable to protect the appliance with a suitable residual current device (RCD).

Maximum connected load: see data plate.

Electrical connection

Electrical connection: Other countries

All electrical work should be carried out by a suitably qualified and competent Miele approved service technician in strict accordance with local and national safety regulations.

The voltage and rated load are given on the data plate situated at the front of the oven interior. Please ensure that these match the household mains supply.

For extra safety it is advisable to install a suitable residual current device (RCD) / ground fault interrupter (GFI). Contact a qualified electrician for advice.

If the cord is damaged a new cord must be fitted by a Miele approved service technician.



**WARNING - THIS APPLIANCE
MUST BE EARTHED**

Appliance and niche dimensions

Dimensions are given in mm.

Installation in a base unit

When building the appliance into a base unit underneath a hob please also observe the installation instructions for the hob as well as the building-in depth required for the hob.

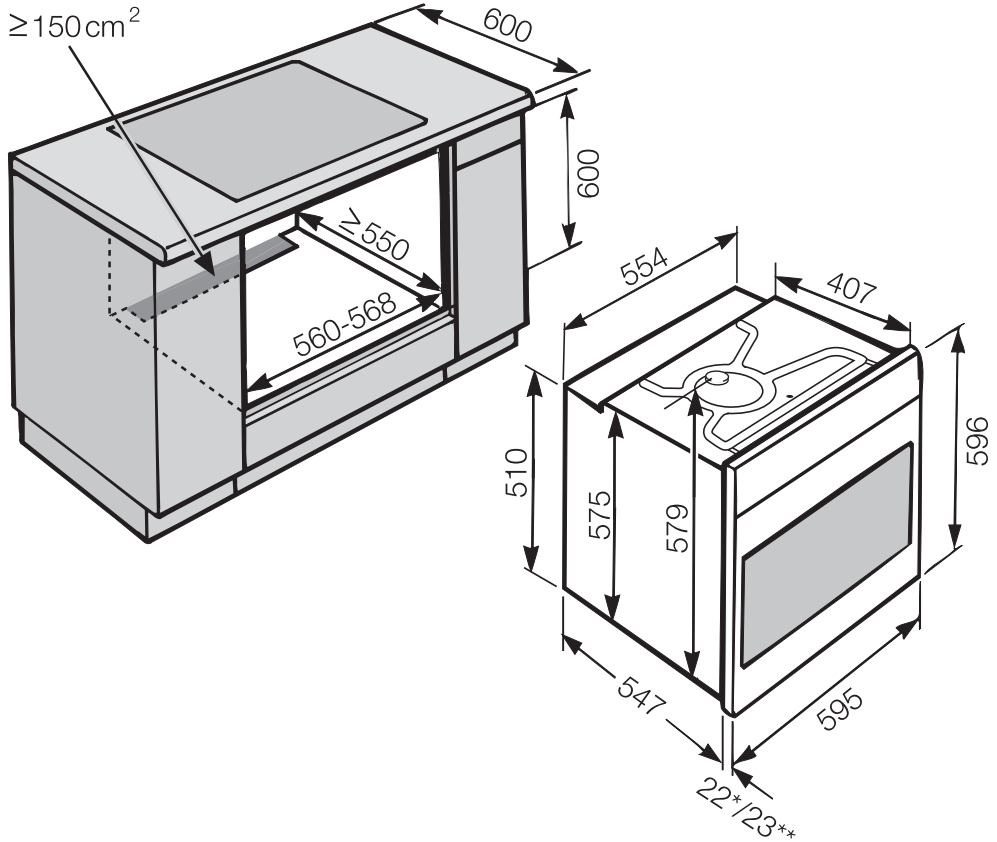

* Ovens with glass front

** Ovens with metal front

Building-in diagrams

Installation in a tall unit

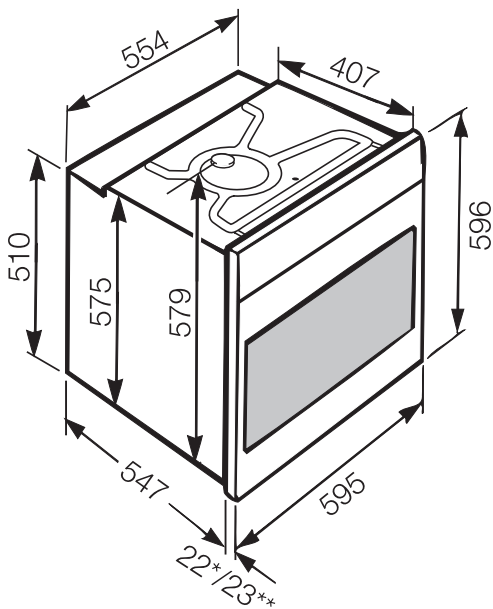
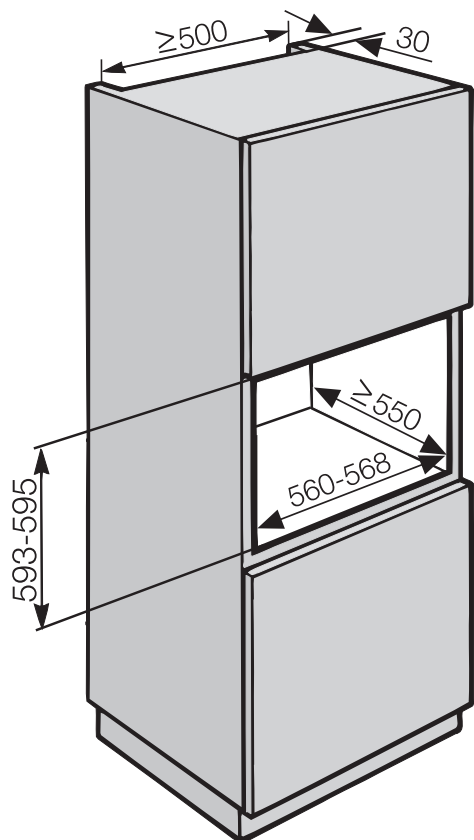

* Ovens with glass front

** Ovens with metal front

Front dimensions

Dimensions are given in mm.

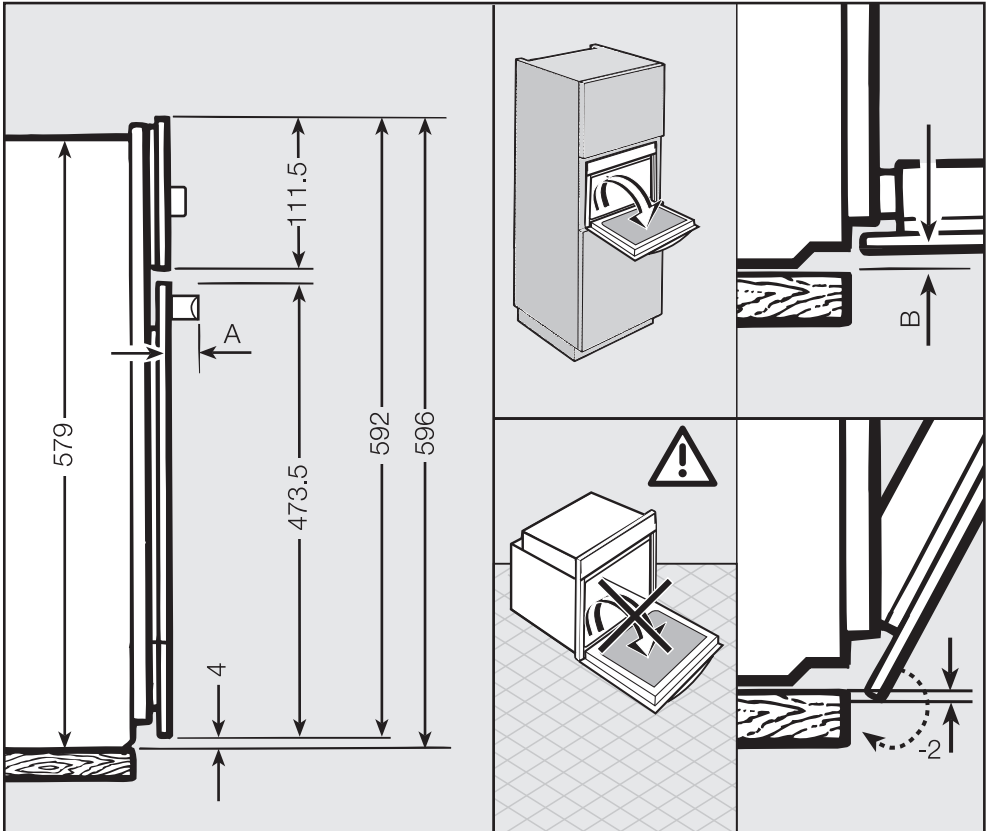

A H61xx: 45 mm

H62xx: 42 mm

B Ovens with glass front: 2.2 mm

Ovens with metal front: 1.2 mm

Installing the oven

⚠ The oven must not be operated until it has been correctly installed in its housing unit.

The oven must have an adequate supply of cool air for proper operation. The required air must not be heated excessively by other heat sources, e.g. wood burning stove.

Observe the following when installing:

Do not fit a back panel in the housing unit.

Make sure that the shelf that the oven sits on does not touch the wall.

Do not fit insulation to the side walls of the housing unit.

Before installation

- Before connecting the appliance to the mains, you must disconnect the power supply to the isolator switch or fused spur connection unit.

Building in

- Connect the mains cable from the oven to the isolator.

Do not carry the oven by the door handle. The door can be damaged. Use the handles on each side of the casing to carry it.

It is advisable to dismantle the door before installing the appliance (see “Cleaning and Care - Dismantling the door”) and remove accessories from the oven cavity. This will make it easier to install in its niche and you will not be tempted into using the handle to carry it.

- Push the oven into the housing unit and align it.
- Open the door (if you have not removed it previously).

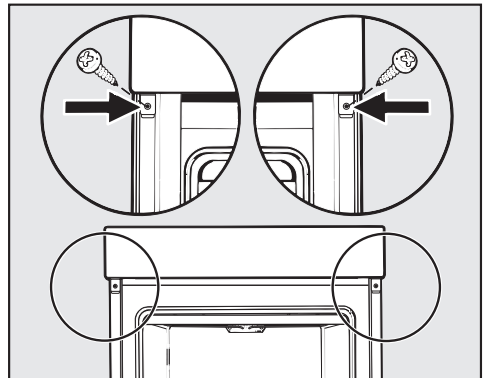

- Use the screws supplied to secure the oven to the side walls of the housing unit through the holes in the oven trim.
- Refit the door, if necessary (see “Cleaning and care - Refitting the door”).

The recipe section contains recipes for baking, roasting and cooking with Moisture Plus.

Quantities and settings are specifically formulated for your oven.

Recipes

Bake-off products

Ingredients

Frozen or unchilled part-baked rolls
Deep frozen salted pretzels
Crystal salt
Bread rolls (made from ready-made dough)
Croissants (made from ready-made dough)

Method for part-baked rolls

Place the rolls on a baking tray, Gourmet perforated baking tray or the rack.

Method for pretzels

Place the pretzels on a baking tray covered with baking parchment.

Leave to thaw for 10 minutes and then scatter with crystal salt.

Method for bread rolls or croissants made from ready-made dough

Prepare and roll out the dough according to the packet instructions, then place the rolls or croissants on a baking tray or Gourmet perforated baking tray.

Thanks to the PerfectClean finish, baking and universal trays do not need to be greased or lined with baking paper unless you are baking items with a high sodium content like pretzels, and items with a lot of sugar and egg white such as sponge mixes, macaroons and meringue.

Settings for part-baked rolls and pretzels

Pre-heat the oven according to the packet instructions.

Oven function: Moisture plus 

Temperature: see packet instructions for Fan heat

Pre-heat: yes

Shelf level: 2

Number/type of bursts of steam: 1/ manual

Amount of water: approx. 100 ml

1st burst of steam:

after placing food in the oven

Duration:

as per packet instructions plus approx. 5 minutes

It is not necessary to pre-heat the oven.

Oven function: Moisture plus 

Temperature: see packet instructions for Fan heat

Shelf level: 2

Number/type of bursts of steam: 1/automatic

Amount of water: approx. 100 ml

1st burst of steam: automatic

Duration:

as per packet instructions plus approx. 5 minutes

Method for bread rolls or croissants made from ready-made dough

It is not necessary to pre-heat the oven.

Oven function: Moisture plus 

Temperature: see packet instructions
for Fan heat

Shelf level: 2

Number/Type of bursts of steam:

1 burst of steam/Manual

Amount of water: approx. 100 ml

1st burst of steam:

3 minutes after the start of the
programme

Duration:

as per packet instructions plus approx.

5 minutes

Recipes

White bread

Preparation time: 80–95 minutes

Ingredients

½ cube of fresh yeast (21 g)
250 ml lukewarm water
500 g strong white flour
1½ tsp salt
1 tsp sugar
15 g softened butter

For glazing

Milk

Accessories

Baking tray/Gourmet perforated baking tray

Method

Dissolve the yeast in lukewarm water. Then add to the flour, salt, sugar and butter and knead for 4–5 minutes until you get a smooth dough.

Shape the dough into a ball. Cover and place in the oven to prove for 30 minutes using Conventional heat at 35 °C.

Lightly knead the dough and shape into a loaf approx. 25 cm long and place on the baking tray or the Gourmet perforated baking tray. Make several diagonal cuts about 1 cm deep in the surface of the loaf using a sharp knife. Then cover and place in the oven to prove for a further 15-20 minutes using Conventional heat at 35 °C.

Brush the top with water and bake until golden.

Setting

Oven function: Moisture plus 
Number/type of bursts of steam: 1
Temperature: 180–190 °C + pre-heating
Amount of water: approx. 100 ml
Shelf level: 2
1st burst of steam:
after placing food in the oven
Duration: 35–45 minutes

Flat bread

Preparation time: 75–90 minutes

Ingredients

1 cube of fresh yeast (42 g)
200 ml lukewarm water
375 g strong white flour
1 tsp salt
2 tbsp oil

For glazing

1 ½ tbsp vegetable oil

Accessories

Baking tray/Gourmet perforated baking tray

Method

Dissolve the yeast in lukewarm water. Then add to the flour, salt and oil and knead for 3–4 minutes until you get a smooth dough. Cover and prove in the oven for 20–30 minutes using Conventional heat at 35 °C.

Lightly knead the dough and roll out into the shape of a flat bread (Ø approx. 25 cm). Place on the baking tray or the Gourmet perforated baking tray, cover and leave to prove at room temperature for another 15 minutes.

Brush the top with oil and bake until golden.

Setting

Oven function: Moisture plus 
Number/Type of bursts of steam: Automatic
Temperature: 200–210 °C
Amount of water: approx. 100 ml
Shelf level: 2
1st burst of steam: automatic
Duration: 25–30 minutes

Tip

For a variation of this flat bread, knead one of the following into the dough: 50 g of fried onions; 2 tsp of chopped rosemary; or a mixture of 40 g chopped black olives and 1 tbsp chopped pine nuts or 1 tsp chopped herbs de Provence. Sprinkle the top with black sesame seed and bake.

Recipes

Herb bread

Preparation time: 110–130 minutes

Ingredients

½ cube of fresh yeast (21 g)
300 ml lukewarm milk
500 g strong white flour
1 tsp salt
1 tbsp coarsely chopped parsley
1 tbsp coarsely chopped fresh dill
1 tbsp coarsely chopped chives

For glazing

Milk

Accessories

Loaf tin, 30 cm long

Method

Dissolve the yeast in lukewarm milk. Then add to the flour, salt and herbs and knead for 3-4 minutes until you get a smooth dough. Cover the dough and place in the oven to prove for 30-40 minutes using Conventional heat at 35 °C.

Place the dough in the greased loaf tin. Slash the top of the dough in a criss-cross pattern with a sharp knife. Place in the oven and prove for 15-20 minutes using Conventional heat at 35 °C.

Brush the top with milk and bake until golden.

Setting

Oven function: Moisture plus 
Number/type of bursts of steam: 2
Temperature: 150–160 °C
Amount of water: approx. 200 ml
Shelf level: 2
1st burst of steam:
5 minutes after the start of the programme
2nd burst of steam:
after another 10 minutes
Duration: 50–60 minutes

Olive bread

Preparation time: 170–200 minutes

Ingredients

450 g strong white flour
½ cube of fresh yeast (21 g)
150 ml white wine
4 eggs
50 ml olive oil
100 g ham, finely diced
100 g grated pecorino cheese
1 tsp dried marjoram
½–1 tsp salt
100 g chopped walnuts
100 g black olives, coarsely chopped

Accessories

Loaf tin, 30 cm long

Method

Knead the flour, yeast, wine, eggs and oil to a smooth dough, cover and prove for 40–50 minutes using Conventional heat at 35 °C.

Then mix the ham, cheese, marjoram and salt and knead into the dough with the chopped walnuts. Finally knead in the coarsely chopped olives.

Place the very soft dough into the greased loaf tin, cover and place in the oven. Prove for 40–50 minutes using Conventional heat at 35 °C. Slash the top of the loaf lengthways and then bake until golden.

Setting

Oven function: Moisture plus 
Number/type of bursts of steam: 2
Temperature: 160–170 °C
Amount of water: approx. 200 ml
Shelf level: 2
1st burst of steam:
5 minutes after the start of the programme
2nd burst of steam:
after another 10 minutes
Duration: 65–75 minutes

Recipes

Sesame cheese rolls

Preparation time: 75–90 minutes

10 rolls

Ingredients

1 cube of fresh yeast (42 g)
150 ml lukewarm milk
500 g strong white flour
1 heaped tsp salt
A pinch of sugar
75 g melted butter
40 g Parmesan cheese, finely grated
2 eggs
6 tbsp sesame seeds

For glazing

1 egg

To sprinkle on top

120 g shaved Cheddar, Cheshire or Gouda cheese

Accessories

Baking tray
Baking parchment

Method

Dissolve the yeast in lukewarm milk. Then add to the flour, sugar, salt, butter, parmesan and eggs and knead for 3–4 minutes until you get a smooth dough. Cover and place in the oven to prove for 20 - 30 minutes on Conventional heat at 35 °C.

Lightly knead the dough then shape into 10 evenly sized balls. Place on a baking tray lined with baking parchment. Cover and place in the oven to prove for a further 10-15 minutes using Conventional heat at 35 °C.

Press the bottom of each roll into the sesame seeds. Brush the tops with the beaten egg and sprinkle generously with cheese. Place in the oven and bake until golden.

Setting

Oven function: Moisture plus 
Number/type of bursts of steam: 1
Temperature: 150–160 °C
Amount of water: approx. 100 ml
Shelf level: 2
1st burst of steam:
after placing food in the oven
Duration: 25–35 minutes

Tip

You can also top the rolls with sesame seeds in addition to the cheese.

Rye bread

Preparation time: 120–135 minutes

Ingredients

400 g rye flour
200 g strong white flour
2½ tsp salt
2 tsp honey
150 g liquid sourdough
1 cube of fresh yeast (42 g)
400 ml lukewarm water
5 tbsp linseed
4 tbsp sunflower seeds

For glazing

Water

Accessories

Loaf tin, 30 cm long

Method

Mix the strong white flour with the rye flour and the salt. Then add the sourdough and the honey.

Dissolve the yeast in the lukewarm water and add it to the flour. It is best to knead this heavy dough in a kitchen mixer using dough hooks for about 4 minutes. Cover and prove for 30–45 minutes in the oven using Conventional heat at 35 °C.

Knead in the linseed and the sunflower seeds. Place the dough in the greased loaf tin. Level the top and brush with water and prove for a further 15–20 minutes in the oven using Conventional heat at 35 °C.

Bake in the pre-heated oven until golden. The oven temperature should be reduced after the first 15 minutes.

Setting

Oven function: Moisture plus 
Number/type of bursts of steam: 2
Temperature: 180–190 °C + pre-heating
Amount of water: approx. 200 ml
Shelf level: 2
1st burst of steam:
after placing food in the oven
2nd burst of steam:
after another 10 minutes
Duration: 50–60 minutes

Recipes

Mixed grain bread

Preparation time: 115–150 minutes

Ingredients

½ cube of fresh yeast (21 g)
1 tbsp malt extract
400 ml lukewarm water
200 g rye flour
400 g strong white flour
3 tsp salt
75 g liquid sourdough

For glazing

Water

Accessories

Loaf tin, 30 cm long

Method for Moisture plus

Dissolve the yeast and malt extract in the lukewarm water.

Mix the rye flour, strong white flour and salt and then add the sourdough. Add the malted water and knead for about 4 minutes until you get a smooth dough. Place in the oven and prove for 40–45 minutes using Conventional heat at 35 °C.

Lightly knead the dough again, then place it in the greased loaf tin. Level the top then brush with water, cover and place in the oven. Prove for a further 25–30 minutes using Conventional heat at 35 °C.

Then score the surface lengthways with a sharp knife and bake.

Setting

Oven function: Moisture plus 
Number/type of bursts of steam: 2
Temperature: 190-200 °C + pre-heating
Amount of water: approx. 200 ml
Shelf level: 2
1st burst of steam:
after placing food in the oven
2nd burst of steam:
after another 10 minutes
Duration: 45–55 minutes

Multigrain bread

Preparation time: 80–105 minutes

Ingredients

250 g strong wholemeal flour
250 g wholemeal spelt flour
2½ tsp salt
1½ tsp sugar
3 tbsp linseed
3 tbsp millet seed
3 tbsp sunflower seeds
350 ml lukewarm water
½ cube of fresh yeast (21 g)

For sprinkling in the tin and on top

2 tbsp linseed
2 tbsp millet seed
2 tbsp sunflower seeds

Accessories

Loaf tin, 30 cm long

Method

Mix together the flours, salt, sugar and seeds in a bowl. Dissolve the yeast in the lukewarm water and add to the flour mixture. Knead for 3–4 minutes to form a smooth dough.

Place in the oven to prove for 30–40 minutes using Conventional heat at 35 °C.

Sprinkle the greased long loaf tin with some of the mixed seeds.

Punch down the risen dough, place in the loaf tin and score the surface several times. Prove at room temperature for a further 10 minutes.

Place in the pre-heated oven and bake until golden.

Setting

Oven function: Moisture plus 
Number/type of bursts of steam: 2
Temperature: 180–190 °C + pre-heating
Amount of water: approx. 200 ml
Shelf level: 2
1st burst of steam:
after placing food in the oven
2nd burst of steam:
after another 10 minutes
Duration: 45–55 minutes

Recipes

Yeast rolls

Preparation time: 100–120 minutes
10 rolls

Ingredients

½ cube of fresh yeast (21 g)
270 ml lukewarm water
500 g strong white flour
1½ tsp salt
1 tsp sugar
1 heaped tsp softened butter

For glazing

Water

Accessories

Baking tray/Gourmet perforated baking tray

Method

Dissolve the yeast in lukewarm water. Then add to the flour, salt, sugar and softened butter and knead for 3–4 minutes until you get a smooth dough. Cover and prove for 35–45 minutes in the oven using Conventional heat at 35 °C.

Lightly knead the dough, then shape into 10 evenly sized balls and place on the baking tray or the Gourmet perforated baking tray. Score the tops, then prove in the oven for a further 25–35 minutes using Conventional heat at 35 °C.

Brush with water and bake until golden.

Setting

Oven function: Moisture plus 
Number/type of bursts of steam: 1
Temperature: 200–210 °C
Amount of water: approx. 100 ml
Shelf level: 2
1st burst of steam:
after placing food in the oven
Duration: 25–35 minutes

Tip

For milk rolls use 300 ml milk instead of water. For raisin rolls use 300 ml milk instead of water and add 2 tbsp sugar and knead 100 g raisins into the dough.

Seeded rolls

Preparation time: 120–130 minutes
10 rolls

Ingredients

1 cube of fresh yeast (42 g)
1 tsp molasses
1 tbsp malt extract
300 ml lukewarm water
150 g dark rye flour
450 g strong white flour
2–3 tsp salt
75 g sourdough

To sprinkle on top

3 tbsp each of linseed, sesame seeds
and sunflower seeds

Accessories

Baking tray/Gourmet perforated baking
tray

Method

Dissolve the yeast with the molasses
and the malt extract in the lukewarm
water.

Mix the rye flour, strong white flour and
salt and then add the sourdough. Add
the malted water and knead until you
get a smooth dough. Cover and place
in the oven to prove for approx. 30–
45 minutes using Conventional heat at
35 °C.

Mix the linseed with the sesame seeds
and the sunflower seeds.

Lightly knead the dough and shape into
10 rolls. Brush the rolls with water and
dip the tops into the seeds. Place the
rolls on the baking tray or the Gourmet
perforated baking tray. Cover and place

in the oven to prove for 30–40 minutes
using Conventional heat at 35 °C. Then
bake until golden.

Setting

Oven function: Moisture plus 
Number/type of bursts of steam: 1
Temperature: 190–200 °C
Amount of water: approx. 100 ml
Shelf level: 2
1st burst of steam:
after placing food in the oven
Duration: 25–30 minutes

Tip

For a spicy variation add 1/2 tsp mixed
spices (e.g. star anise, coriander and
cumin).

Recipes

Italian Mozzarella bread

Preparation time: 110–120 minutes

Ingredients

1 cube of fresh yeast (42 g)
200 ml lukewarm water
500 g strong white flour
1 tsp salt
3 tbsp olive oil

Topping ingredients

125 g diced Mozzarella
100 g coarsely grated pecorino cheese
2 cloves of garlic, finely chopped
2 tbsp basil, chopped

For glazing

Olive oil

To sprinkle on top

1 tsp coarse grained salt
Some sprigs of rosemary
1 tsp coloured, coarsely ground pepper

Accessories

Baking tray/Gourmet perforated baking tray

Method

Dissolve the yeast in lukewarm water. Then add to the remaining ingredients and knead to a firm dough. Cover and place in the oven for 30–45 minutes to prove using Conventional heat at 35 °C.

Lightly knead the dough and roll out into a rectangle (30 x 40cm). Top with mozzarella, pecorino, garlic and basil then roll up from the shorter side. Place the roll on the baking tray or the Gourmet perforated baking tray. Cover

and place in the oven to prove for a further 15 minutes using Conventional heat at 35 °C.

Score the top of the loaf several times through to at least the second layer with a sharp knife. Brush with olive oil, sprinkle with salt, rosemary and pepper and bake until golden.

Setting

Oven function: Moisture plus 

Number/type of bursts of steam: 2

Temperature: 180–190 °C

Amount of water: approx. 200 ml

Shelf level: 2

1st burst of steam:

after placing food in the oven

2nd burst of steam:

after another 10 minutes

Duration: 35–45 minutes

Tip

For an alternative you could also add 100 g of finely chopped bottled sundried tomatoes or 100 g of sliced black olives before rolling the dough up.

Sunday rolls

Preparation time: 100–115 minutes

8 rolls

Ingredients

½ cube of fresh yeast (21 g)

250 ml lukewarm milk

500 g strong white flour

40 g sugar

A pinch of salt

60 g softened butter

100 g chopped almonds

For glazing

Milk

To sprinkle on top

Crystal sugar

Accessories

Baking tray/Gourmet perforated baking tray

Method

Dissolve the yeast in lukewarm milk. Then add to the flour, sugar, salt and butter and knead until you get a smooth dough. Cover and place in the oven to prove for approx. 30 minutes using Conventional heat at 35 °C.

Knead the chopped almonds into the dough. Shape into 8 rolls and place on the baking tray or the Gourmet perforated baking tray. Cover and place in the oven to prove for a further 20–30 minutes using Conventional heat at 35 °C.

Brush the rolls with milk and sprinkle crystal sugar on top. Bake until golden.

Setting

Oven function: Moisture plus 

Number/type of bursts of steam: 1

Temperature: 150–160 °C

Amount of water: approx. 100 ml

Shelf level: 2

1st burst of steam:

after placing food in the oven

Duration: 35–40 minutes

Recipes

Buttermilk bread

Preparation time: 115–125 minutes

Ingredients

½ cube of fresh yeast (21 g)
300 ml lukewarm buttermilk
375 g strong white flour
100 g rye flour
1 tbsp wheat bran
1 tbsp linseed
1 tsp sugar
2 tsp salt
1 tsp butter

For glazing

Buttermilk

Accessories

Loaf tin, 30 cm long

Method

Dissolve the yeast in lukewarm buttermilk. Then add to the white flour, rye flour, wheat bran, linseed, sugar, salt and butter and knead to a soft, smooth dough. Cover the dough and place in the oven to prove for approx. 30–40 minutes using Conventional heat at 35 °C.

Lightly knead the dough then shape into a long loaf. Place in the greased loaf tin. Cover and prove for a further 20–30 minutes in the oven using Conventional heat at 35 °C.

Slash the top of the loaf, brush with buttermilk and bake until golden.

Setting

Oven function: Moisture plus 
Number/type of bursts of steam: 2
Temperature: 170–180 °C
Amount of water: approx. 200 ml
Shelf level: 2
1st burst of steam:
5 minutes after the start of the programme
2nd burst of steam:
after another 10 minutes
Duration: 45–55 minutes

Chocolate breakfast rolls

Preparation time: 100–110 minutes

8 rolls

Ingredients

1 cube of fresh yeast (42 g)

150 ml lukewarm milk

500 g strong white flour

A pinch of salt

60 g sugar

2 tsp vanilla sugar

75 g softened butter

2 eggs

100 g chocolate drops

For glazing

Milk

Accessories

Baking tray/Gourmet perforated baking tray

Method

Dissolve the yeast in the lukewarm milk. Then add to the flour, salt, sugar, vanilla sugar, butter and eggs and knead until you get a smooth dough. Cover and prove in the oven for 25–35 minutes using Conventional heat at 35 °C.

Add the chocolate and knead briefly into the dough. Form into 8 rolls and place on the baking tray or the Gourmet perforated baking tray. Cover and place in the oven to prove for a further 15–20 minutes using Conventional heat at 35 °C.

Brush with milk and bake until golden brown.

Setting

Oven function: Moisture plus 

Number/type of bursts of steam: 2

Temperature: 150–160 °C

Amount of water: approx. 200 ml

Shelf level: 2

1st burst of steam:

5 minutes after the start of the programme

2nd burst of steam:

after another 10 minutes

Duration: 25–35 minutes

Recipes

Onion flat bread

Preparation time: 100–110 minutes

Ingredients

1 cube of fresh yeast (42 g)
200 ml lukewarm water
375 g strong white flour
1 tsp salt
2 tbsp oil

Topping ingredients

2 small red onions
80 g strong cheese
Thyme

For drizzling

2 tbsp oil

Accessories

Baking tray/Gourmet perforated baking tray

Method

Dissolve the yeast in lukewarm water. Then add to the flour, salt and oil and knead for 3–4 minutes until you get a smooth dough. Cover and prove in the oven for 35–45 minutes using Conventional heat at 35 °C.

Lightly knead the dough and roll out into the shape of a flat bread (Ø approx. 25 cm). Place on the baking tray or the Gourmet perforated baking tray, cover and leave to prove at room temperature for another 15 minutes.

Peel and finely slice the onions. Grate the cheese.

Arrange the onions on the flat bread, scatter with the cheese and thyme, drizzle with oil around the edges and bake until golden.

Setting

Oven function: Moisture plus 

Number/Type of bursts of steam: Automatic

Temperature: 200–210 °C

Amount of water: approx. 100 ml

Shelf level: 2

1st burst of steam: automatic

Duration: 25–35 minutes

Quark rolls

Preparation time: 45–55 minutes
10 rolls

Ingredients

250 g low fat quark
2 eggs
70 g sugar
2 tsp vanilla sugar
A pinch of salt
500 g white flour
5 tsp baking powder
100 g chopped walnuts

For glazing

Milk

To sprinkle on top

Sugar

Accessories

Baking tray/Gourmet perforated baking tray

Method

Mix the quark, eggs, sugar, vanilla sugar and salt. Then sieve the flour and baking powder and gradually add to the quark mix together with the chopped walnuts.

Knead the dough by hand until it is smooth and soft. Add a little more flour if it gets sticky.

Shape the dough into 10 evenly sized balls. Brush with milk, dip in sugar and place on the baking tray or the Gourmet perforated baking tray. Place in the pre-heated oven.

Setting

Oven function: Moisture plus 
Number/type of bursts of steam: 1
Temperature: 150–160 °C + pre-heating
Amount of water: approx. 100 ml
Shelf level: 2
1st burst of steam:
after placing food in the oven
Duration: 25–35 minutes

Tip

Homemade vanilla sugar:
cut a vanilla pod in half lengthways and cut each half into 4-5 pieces. Place in a lidded glass jar with 500 g of caster sugar and leave for 3 days to absorb the flavour. For an even more intensive flavour scrape the pulp out of the vanilla pod and add this to the sugar.

Recipes

Buttermilk loaf

Preparation time: 110–140 minutes

Ingredients

1 cube of fresh yeast (42 g)
240 ml lukewarm buttermilk
500 g strong white flour
100 g sugar
A pinch of salt
20 g melted butter
125 g low fat quark
250 g raisins

For glazing

Water

Accessories

Loaf tin, 30 cm long

Method

Dissolve the yeast in lukewarm buttermilk. Then add to the flour, sugar, salt, butter and quark and knead until you get a smooth dough. Cover and place in the oven to prove for 25–35 minutes using Conventional heat at 35 °C.

Knead in the raisins then place the dough in the greased loaf tin. Cover and place in the oven to prove for approx. 20–25 minutes using Conventional heat at 35 °C.

Brush the top with water and then bake until golden.

Setting

Oven function: Moisture plus 
Number/type of bursts of steam: 1
Temperature: 150–160 °C
Amount of water: approx. 100 ml
Shelf level: 2
1st burst of steam:
5 minutes after the start of the programme
Duration: 55–65 minutes

Malted pumpkin seed rolls

Preparation time: 120–130 minutes
8 rolls

Ingredients

1 cube of fresh yeast (42 g)
1 tbsp malt extract
300 ml lukewarm water
500 g wholemeal flour
3 tsp salt
50 g pumpkin seeds, chopped

Accessories

Baking tray/Gourmet perforated baking tray

Method

Dissolve the yeast and malt extract in lukewarm water. Then add to the flour, salt and chopped pumpkin seeds and knead to a smooth dough. Cover and place in the oven to prove for approx. 35–45 minutes using Conventional heat at 35 °C.

Lightly knead the dough again and shape into 8 rolls. Brush with a little water, then cut a cross into the top of each and place on the baking tray or the Gourmet perforated baking tray. Cover and place in the oven to prove for a further 30–40 minutes using Conventional heat at 35 °C.

Setting

Oven function: Moisture plus 
Number/type of bursts of steam: 1
Temperature: 190–200 °C
Amount of water: approx. 100 ml
Shelf level: 2
1st burst of steam:
after placing food in the oven
Duration: 25–30 minutes

Tip

Malt extract contains enzymes that speed up the rate that yeast grows at. It also gives bread and rolls a pleasant sweet taste and a nice dark colour. It is available from health food shops and most supermarkets.

Recipes

Yeast dough men

Preparation time: 95–105 minutes

Makes 4

Ingredients

½ cube of fresh yeast (21 g)

200 ml lukewarm milk

375 g strong white flour

50 g sugar

A pinch of salt

50 g softened butter

For glazing

1 egg

To decorate

Raisins

Almonds

Accessories

Baking tray/Gourmet perforated baking tray

Method

Dissolve the yeast in lukewarm milk. Then add to the flour, sugar, salt and butter and knead until you get a smooth dough. Cover and place in the oven to prove for 25–35 minutes using Conventional heat at 35 °C.

Lightly knead the dough again. Dust the worksurface with flour, then roll the dough out about 1 cm thick and cut into dough men shapes. Place the dough men on the baking tray or Gourmet perforated baking tray. Cover and place in the oven to prove a further 15–20 minutes using Conventional heat at 35 °C.

Whisk the egg, brush on dough men, decorate with raisins and almonds and bake until golden.

Setting

Oven function: Moisture plus 

Number/type of bursts of steam: 1

Temperature: 160–170 °C

Amount of water: approx. 100 ml

Shelf level: 2

1st burst of steam:

after placing food in the oven

Duration: 20–30 minutes

Yeast pretzels

Preparation time: 85–95 minutes

Makes 8

Ingredients

½ cube of fresh yeast (21 g)

100 ml lukewarm milk

300 g strong white flour

1 tsp sugar

1 tsp salt

30 g butter

1 egg

For glazing

1 egg yolk beaten into 1 tbsp milk

To sprinkle on top

Poppy seeds or grated cheese

Accessories

Baking tray/Gourmet perforated baking tray

Method

Dissolve the yeast in lukewarm milk. Then add to the flour, sugar, salt, butter and egg and knead until you get a smooth dough. Cover and place in the oven to prove for 20 - 30 minutes using Conventional heat at 35 °C.

Lightly knead the dough and then roll into 8 lengths (approx. 0.5 cm Ø). Then shape into pretzels and place on the baking tray or the Gourmet perforated baking tray. Cover and place in the oven to prove for a further 10 minutes using Conventional heat at 35 °C.

Brush with the egg yolk and milk, then sprinkle with poppy seeds or grated cheese. Bake until golden.

Setting

Oven function: Moisture plus 

Number/type of bursts of steam: 1

Temperature: 160–170 °C

Amount of water: approx. 100 ml

Shelf level: 2

1st burst of steam:

after placing food in the oven

Duration: 20–30 minutes

Recipes

Bacon or herb baguettes

Preparation time: 105–130 minutes
2 baguettes

Ingredients

1 cube of fresh yeast (42 g)
250 ml lukewarm water
250 g strong white flour
250 g strong wholemeal flour
1 tsp sugar
2 tsp salt
½ tsp pepper
3 tbsp oil
150 g finely diced cooked ham or
bacon, or 3 tbsp each of chopped
parsley, dill and chives

For glazing

Milk

Accessories

Baking tray/Gourmet perforated baking
tray

Method

Dissolve the yeast in lukewarm water.
Then add to the flour, sugar, salt,
pepper and oil and knead for 3–
4 minutes until you get a smooth
dough. Cover and prove in the oven for
40–50 minutes using Conventional heat
at 35 °C.

Knead in the bacon or the herbs. Shape
the dough into two approx. 35 cm long
baguettes and place on the baking tray
or the Gourmet perforated baking tray.
Score the baguettes diagonally, cover
and place in the oven to prove for a
further 15–20 minutes using
Conventional heat at 35 °C.

Brush the baguettes with milk and then
bake until golden.

Setting

Oven function: Moisture plus 
Number/type of bursts of steam: 1
Temperature: 190–200 °C
Amount of water: approx. 100 ml
Shelf level: 2
1st burst of steam:
after placing food in the oven
Duration: 20–30 minutes

Ham and cheese rolls

Preparation time: 110–120 minutes

8 rolls

Ingredients

½ cube of fresh yeast (21 g)
250 ml lukewarm water
500 g strong white flour
30 g butter
½ tsp salt
100 g cooked ham, finely diced
100 g mature Cheddar cheese, grated

For glazing

Water

Accessories

Baking tray/Gourmet perforated baking tray

Method

Dissolve the yeast in lukewarm water. Then add to the flour, salt and butter and knead until you get a smooth dough. Cover the dough and place in the oven to prove for about 25–35 minutes using Conventional heat at 35 °C.

Knead the ham and half of the grated cheese into the dough.

Shape the dough into 8 rolls and place on the baking tray or the Gourmet perforated baking tray. Cover and place in the oven to prove for a further 15–20 minutes using Conventional heat at 35 °C.

Brush the rolls with water and top with the rest of the cheese. Bake until golden.

Setting

Oven function: Moisture plus 
Number/type of bursts of steam: 1
Temperature: 180–190 °C
Amount of water: approx. 100 ml
Shelf level: 2
1st burst of steam:
after placing food in the oven
Duration: 25–35 minutes

Tip

Instead of Cheddar cheese try making these rolls with Emmental, Gruyere or a mature Gouda cheese.

Recipes

Apricot loaf

Preparation time: 110–120 minutes

Ingredients

1 cube of fresh yeast (42 g)
200 ml lukewarm milk
500 g strong white flour
60 g sugar
2 tsp vanilla sugar
A pinch of salt
1 tsp lemon zest
100 g softened butter
1 egg
100 g dried apricots
50 g chopped pistachio nuts

For glazing

Milk

Accessories

Loaf tin, 30 cm long

Method

Dissolve the yeast in lukewarm milk. Then add to the flour, sugar, vanilla sugar, salt, lemon zest, butter and egg and knead until you get a smooth dough. Cover the dough and place in the oven to prove for about 25–35 minutes using Conventional heat at 35 °C.

Dice the apricots and knead into the dough with the pistachios. Shape into a loaf and place in the greased loaf tin. Cover and place in the oven to prove for a further 15 minutes using Conventional heat at 35 °C.

Glaze the apricot loaf with milk and then bake.

Setting

Oven function: Moisture plus 
Number/type of bursts of steam: 2
Temperature: 150–160 °C
Amount of water: approx. 200 ml
Shelf level: 2
1st burst of steam:
5 minutes after the start of the programme
2nd burst of steam:
after another 10 minutes
Duration: 50–60 minutes

Butter cake

Preparation time: 90–110 minutes

Serves 20

Ingredients

1 cube of fresh yeast (42 g)

200 ml lukewarm milk

500 g strong white flour

50 g sugar

A pinch of salt

50 g butter

1 egg

Topping ingredients

100 g butter

100 g flaked almonds

120 g sugar

4 tsp vanilla sugar

Accessories

Universal tray

Method

Dissolve the yeast in lukewarm milk. Then add to the flour, sugar, salt, butter and egg and knead until you get a smooth dough. Cover and place in the oven to prove for 20 - 25 minutes using Conventional heat at 35 °C.

Lightly knead the dough and then roll out onto the universal tray. Cover and place in the oven to prove for a further 20 minutes using Conventional heat at 35 °C.

Mix the butter with the vanilla sugar and half of the sugar. Make indentations in the dough with your fingers and then, using two teaspoons, drop small balls of the mixture into the indentations. Sprinkle the remaining sugar and flaked almonds over the top.

Allow to prove for another 10 minutes and bake until golden.

Setting

Oven function: Moisture plus 

Number/type of bursts of steam: 1

Temperature: 170–180 °C + pre-heating

Amount of water: approx. 100 ml

Shelf level: 2

1st burst of steam:

5 minutes after the start of the programme

Duration: 20–25 minutes

Recipes

Pine nut and almond cake

Preparation time: 130–140 minutes

Serves 20

Ingredients

30 g fresh yeast
200 ml lukewarm milk
500 g strong white flour
80 g sugar
A pinch of salt
80 g softened butter
1 egg

Topping ingredients

150 g butter
200 g sugar
2 tbsp honey
3 tbsp double cream
100 g chopped pine nuts
100 g flaked almonds

Filling ingredients

1 packet of vanilla custard powder
500 ml milk
3 tbsp sugar
A pinch of salt
250 g softened butter

Accessories

Universal tray

Method

Dissolve the yeast in lukewarm milk. Then add to the flour, sugar, salt, butter and egg and knead until you get a smooth dough. Cover and place in the oven to prove for 25–35 minutes using Conventional heat at 35 °C.

Lightly knead the dough and then roll out onto the universal tray. Cover and place in the oven to prove for a further 20 minutes using Conventional heat at 35 °C.

To make the topping heat the butter, sugar, honey and cream in a pan on the hob and bring to the boil. Add the chopped pine nuts and sliced almonds. Leave to cool. Make indentations in the dough with your fingers and then spread the cooled topping smoothly over the dough. Prove the cake for another 10 minutes and then bake until golden.

Make the filling by heating up the vanilla custard powder with the milk, sugar and salt. Leave to cool. In the meantime cream the butter and then stir the custard mix into it a spoonful at a time.

Cut the cake through the middle when it has cooled down. Spread the bottom layer with the filling and then carefully place the top layer on the filling. Leave to chill before serving.

Setting

Oven function: Moisture plus 
Number/Type of bursts of steam: Automatic
Temperature: 160–170 °C
Amount of water: approx. 100 ml
Shelf level: 2
1st burst of steam: automatic
Duration: 25–30 minutes

Plaited walnut loaf

Preparation time: 100–110 minutes

Serves 10

Ingredients

1 cube of fresh yeast (42 g)

200 ml lukewarm milk

500 g strong white flour

50 g sugar

2 tsp vanilla sugar

A pinch of salt

100 g softened butter

1 egg

100 g chopped walnuts

For glazing

Milk

Accessories

Baking tray/Gourmet perforated baking tray

Method

Dissolve the yeast in the lukewarm milk. Then add to the flour, sugar, vanilla sugar, salt, butter and egg and knead to form a smooth dough. Cover and place the dough in the oven to prove for 30–40 minutes using Conventional heat at 35 °C.

Add the chopped walnuts and knead into the dough. Form three 40 cm long rolls out of the dough. Plait the strips and place on baking tray or the Gourmet perforated baking tray.

Cover and prove at room temperature for 10 minutes.

Brush the loaf with milk and bake.

Setting

Oven function: Moisture plus 

Number/type of bursts of steam: 1

Temperature: 150–160 °C

Amount of water: approx. 100 ml

Shelf level: 2

1st burst of steam:

15 minutes after the start of the programme

Duration: 30–40 minutes

Recipes

Cinnamon and macadamia ring

Preparation time: 115–125 minutes

Serves 10

Ingredients

1 cube of fresh yeast (42 g)

100 ml lukewarm milk

500 g strong white flour

100 g sugar

A pinch of salt

Zest of 1 lemon

100 g softened butter

1 egg

2 egg whites

Topping ingredients

1 tsp ground cinnamon

2 tbsp sugar

100 g unsalted, chopped macadamia nuts

2 egg yolks

For glazing

Milk

Accessories

Baking tray/Gourmet perforated baking tray

Method

Dissolve the yeast in lukewarm milk. Then add to the flour, sugar, salt, lemon zest, butter and egg white and knead until you get a smooth dough. Cover and place in the oven to prove for 25–35 minutes using Conventional heat at 35 °C.

Lightly knead the dough and divide into two. Shape each half in 50–60 cm long rolls, then twist these together and form into a ring. Place the dough on the baking tray or the Gourmet perforated

baking tray, cover then prove for a further 20 minutes using Conventional heat at 35 °C.

Mix the cinnamon with the sugar, chopped nuts and the egg yolks. Brush with the milk, sprinkle with the nut mixture and prove for a further 15–20 minutes using Conventional heat at 35 °C. Bake until golden.

Setting

Oven function: Moisture plus 

Number/type of bursts of steam: 2

Temperature: 150–160 °C

Amount of water: approx. 200 ml

Shelf level: 2

1st burst of steam:

5 minutes after the start of the programme

2nd burst of steam:

after another 10 minutes

Duration: 30–35 minutes

Tip

Macadamia nuts originate from Australia and are one of the most expensive nuts in the world. This queen of nuts is rich in unsaturated fat, which gives it its soft creamy taste.

Sea bream in a herb sauce

Preparation time: 45–55 minutes

Serves 4

Ingredients

4 prepared sea bream (approx. 400 g each)

40 ml olive oil

Salt

Pepper

Sauce

30 g butter

20 g plain flour

4 tbsp white wine

375 ml stock

100 ml double cream

1½ tbsp chopped parsley

Salt

Pepper

Sugar

2 lemons

Accessories

Universal tray

Saucepan

Method

Season the fish with salt and pepper, brush with oil and place in the universal tray.

Place the fish in the pre-heated oven.

Heat the butter in the saucepan and add the flour. Gradually add the stock and wine and bring to the boil. Add cream and herbs and season with salt, pepper and sugar.

Place the fish on pre-heated plates and serve with half a lemon. Serve the sauce separately.

Setting

Oven function: Moisture plus 

Number/type of bursts of steam: 1

Temperature: 190-200 °C + pre-heating

Amount of water: approx. 100 ml

Shelf level: 2

1st burst of steam:

15 minutes after the start of the programme

Duration: 25–35 minutes

Recipes

Savoy cabbage and salmon gratin

Preparation time: 75–85 minutes

Serves 4

Ingredients

600 g salmon filet
1 small savoy cabbage (approx. 600 g)
20 g softened butter
500 g potatoes
Pepper
Salt
300 g crème fraîche with herbs
2–3 tsp horseradish sauce
80 g grated Cheddar cheese
80 g white bread

Accessories

Frying pan
Saucepan
Ovenproof dish, approx. 20 x 30 cm

Method

Wash and quarter the cabbage, remove the stalk and shred the leaves. Heat the butter in a frying pan, add the cabbage and fry gently for 15 minutes, stirring occasionally.

Peel and slice the potatoes. Parboil for 5 minutes.

Wash and dry the salmon, cut into strips approx. 2 cm wide. Season with salt and pepper. Mix the crème fraîche with the horseradish sauce and the cheese.

Mix the cabbage with the potatoes and place in an ovenproof dish. Arrange the salmon on top. Dice the bread and stir into the crème fraîche. Spread the bread mixture over the top of the salmon and bake.

Setting

Oven function: Moisture plus 
Number/type of bursts of steam: 3
Temperature: 160–170 °C
Amount of water: approx. 300 ml
Shelf level: 2
1st burst of steam:
5 minutes after the start of the programme
2nd burst of steam:
after another 10 minutes
3rd burst of steam:
after another 10 minutes
Duration: 35–45 minutes

Stuffed salmon trout

Preparation time: 50–60 minutes

Serves 4

Ingredients

1 salmon trout (900 g)
Juice of one lemon
Salt
1 shallot
1 clove of garlic
30 g small capers
1 egg yolk
2 tbsp olive oil
1 slice of white bread
Chilli powder
Freshly ground pepper

Accessories

Universal tray

Method

Rinse the salmon trout, pat dry, drizzle with lemon juice and season inside and out with salt.

Peel and finely chop the shallots and garlic. Cut the bread into small cubes and mix with the capers, egg yolk, shallots, garlic and olive oil. Season with salt, pepper and chilli powder.

Stuff the fish with this mixture and seal the opening with small wooden skewers.

Place the fish on the universal tray lined with baking paper, and cook in the pre-heated oven.

Setting

Oven function: Moisture plus 
Number/type of bursts of steam: 2
Temperature: 190-200 °C + pre-heating
Amount of water: approx. 200 ml
Shelf level: 2
1st burst of steam:
5 minutes after the start of the programme
2nd burst of steam:
after another 10 minutes
Duration: 35–40 minutes

Tip

Stuffed or unstuffed fish can be cooked using this Automatic programme. Brush with oil to ensure that fish remains moist and crisps up nicely.

Recipes

Pollock, Viennese style

Preparation time: 60–70 minutes

Serves 4

Ingredients

600 g pollock fillet (3 fillets, 200 g each)

Juice of one lemon

125 g crème fraîche

50 g pickled gherkins

10 g capers

30 g streaky bacon

1 tbsp mustard

1 tsp grated Parmesan cheese

Accessories

Ovenproof dish, approx. 20 x 30 cm

Method

Rinse the fish fillet, pat dry and drizzle with lemon juice. Place one fillet in the greased casserole dish and coat with half of the crème fraîche.

Rinse the gherkins and capers. Then dice the bacon and the gherkins and mix with the chopped up capers.

Place a third of the gherkin mixture on top of the fish fillet. Then place a second fillet on top. Coat with mustard and another third of the gherkin mixture.

Top this with the last fish fillet, coat with the remaining crème fraîche and then the rest of the gherkin mixture. Scatter Parmesan over the top and bake.

Setting

Oven function: Moisture plus 

Number/type of bursts of steam: 2

Temperature: 160–170 °C

Amount of water: approx. 200 ml

Shelf level: 2

1st burst of steam:

10 minutes after the start of the programme

2nd burst of steam:

after another 10 minutes

Duration: 30–40 minutes

Salmon and spinach pasta bake

Preparation time: 60–70 minutes

Serves 4

Ingredients

450 g fresh or frozen spinach
1 clove of garlic
Salt
Nutmeg
500 g green tagliatelli
400 g salmon fillet
10–20 ml lemon juice
Freshly ground pepper
200 ml double cream
250 g soured cream
2 tbsp mixed Italian herbs
20 g flaked almonds

Accessories

Saucepan
Ovenproof dish, approx. 20 x 30 cm

Method

Defrost frozen spinach or blanch fresh spinach in boiling water for 1 minute then drain well. Squeeze any excess water out by hand.

Roughly chop the spinach and season with garlic, salt and a little nutmeg.

Cook the tagliatelle to “al dente”.

Rinse the salmon, pat dry, dice coarsely, drizzle with lemon juice and season with salt and pepper.

Mix the cream and soured cream with the herbs and season with salt and pepper. Place layers of tagliatelle, salmon and spinach in the greased ovenproof dish. Pour the sauce on top, sprinkle with almond flakes and bake uncovered.

Setting

Oven function: Moisture plus 
Number/type of bursts of steam: 2
Temperature: 160–170 °C
Amount of water: approx. 200 ml
Shelf level: 2
1st burst of steam:
5 minutes after the start of the programme
2nd burst of steam:
after another 10 minutes
Duration: 35–40 minutes

Recipes

Salmon fillet in a Muscadet sauce

Preparation time: 65–75 minutes

Serves 4

Ingredients

6 salmon fillets (120–150 g each)

3 tbsp oil

Salt

Pepper

Sauce

100 ml Muscadet

160 g butter

Salt

Pepper

Sugar

2 lemons

Accessories

Gourmet oven dish

Saucepan

Method

Season the salmon fillets, brush with oil and place in a dish which has been greased with oil.

Place the fish in the pre-heated oven.

Allow the Muscadet to reduce in the pan, add the butter in small pieces and beat well with a whisk. Season with salt, pepper and sugar.

Place the salmon fillets on a pre-heated plate with half a lemon. Serve the sauce separately.

Setting

Oven function: Moisture plus 

Number/type of bursts of steam: 1

Temperature: 190-200 °C + pre-heating

Amount of water: approx. 100 ml

Shelf level: 2

1st burst of steam:

9 minutes after the start of the programme

Duration: 25–30 minutes

Tip

The Muscadet can be replaced with any dry, fruity white wine.

Pollock delicioso

Preparation time: 60–70 minutes

Serves 4

Ingredients

600 g pollock fillets (4–6 pieces)

3 onions

40 g butter

500 g tomatoes

Juice of half a lemon

Salt

Pepper

100 ml milk

10 g breadcrumbs

2 tbsp parsley, chopped

Accessories

Saucepan

Ovenproof dish, Ø 26 cm

Method

Slice the onions finely then sauté them in half the butter. Slice the tomatoes.

Pat the fish dry with kitchen paper then drizzle with lemon juice and season with salt and pepper.

Put the onions in the greased ovenproof dish. Arrange the tomatoes on top and season with salt and pepper.

Arrange the fish on top. Melt the remaining butter, add the milk and pour over the fish. Sprinkle with breadcrumbs and bake. Before serving garnish with chopped parsley.

Setting

Oven function: Moisture plus 

Number/type of bursts of steam: 1

Temperature: 160–170 °C + pre-heating

Amount of water: approx. 100 ml

Shelf level: 2

1st burst of steam:

immediately after starting the programme

Duration: 35–45 minutes

Recipes

Trout stuffed with mushrooms

Preparation time: 40–50 minutes

Serves 4

Ingredients

4 trout, oven-ready (250 g each)

2 tbsp lemon juice

Salt

Pepper

½ onion

1 clove of garlic

200 g fresh mushrooms, sliced

25 g parsley

50 g butter

Accessories

Gourmet oven dish, large/Universal tray

Method

Rinse the trout, pat dry, drizzle with lemon juice inside and out and season with salt and pepper.

Finely dice the onion and the garlic, chop the mushrooms and parsley, mix well and season with salt and pepper.

Fill the trout with the mixture and place them next to each other in the large gourmet oven dish or in the universal tray. Dot with butter and bake.

Setting

Oven function: Moisture plus 

Number/type of bursts of steam: 1

Temperature: 190-200 °C + pre-heating

Amount of water: approx. 100 ml

Shelf level: 2

1st burst of steam:

10 minutes after the start of the programme

Duration: 20–30 minutes

Pikeperch with herbs

Preparation time: 50–60 minutes

Serves 4

Ingredients

800 g pikeperch fillets
Juice of one lemon
1 bunch of parsley
1 bunch of chives
1 bunch of dill
1 bunch of lemon balm mint
Salt
50 g butter

Accessories

Ovenproof dish, shallow

Method

Rinse the fish, pat dry and drizzle with a little lemon juice. Leave to stand for about 10 minutes. Wash the herbs, finely chop them and mix well. Arrange in the bottom of the shallow, greased ovenproof dish.

Season the fish with salt and arrange them, overlapping each other on top of the herbs. Drizzle with the remaining lemon juice, dot with butter and bake.

Setting

Oven function: Moisture plus 
Number/type of bursts of steam: 2
Temperature: 160–170 °C
Amount of water: approx. 200 ml
Shelf level: 2
1st burst of steam:
5 minutes after the start of the programme
2nd burst of steam:
after another 10 minutes
Duration: 35–45 minutes

Recipes

Sweet and sour chicken

Preparation time: 65–75 minutes

Serves 6

Ingredients

800 g chicken breast

400 g plums, stoned

40 g fresh ginger

1 small bunch of spring onions

Salt

Pepper

3 tbsp oil

40 g butter

100 ml white wine

100 ml orange juice

100 ml chicken stock

1 tsp honey

50 ml double cream

Accessories

Gourmet oven dish

Method

Peel the ginger and grate finely. Cut the spring onions into 2 cm pieces.

Season the chicken with salt and pepper. Heat the oil in the Gourmet oven dish and sear the chicken briefly. Add the butter, spring onions and ginger and fry briefly.

Add the white wine, orange juice and chicken stock. Add the plums and honey and pour the cream over the chicken. Cook in the oven. Thicken the sauce if necessary using a little cornflour mixed with water.

Setting

Oven function: Moisture plus 

Number/Type of bursts of steam: Automatic

Temperature: 150–160 °C

Amount of water: approx. 100 ml

Shelf level: 2

1st burst of steam: automatic

Duration: 40–50 minutes

Herby chicken fillets

Preparation time: 55–65 minutes

Serves 4

Ingredients

800 g chicken breast
500 g crème fraîche with herbs
½ tsp Sambal Oelek
2 tsp soy sauce
1 tbs mixed herbs or parsley
100 ml chicken stock

Accessories

Gourmet oven dish/Shallow ovenproof dish

Method

Mix half the crème fraîche with the Sambal Oelek, soy sauce and herbs. Dip the chicken in the mixture and place in the Gourmet oven dish or shallow ovenproof dish without a lid.

Stir the remaining herb mixture into the chicken stock and pour over the chicken. Place in the pre-heated oven and cook.

Remove the chicken at the end of the programme. Stir the rest of the crème fraîche into the juices and serve separately.

Setting

Oven function: Moisture plus 
Number/type of bursts of steam: 2
Temperature: 160–170 °C + pre-heating
Amount of water: approx. 200 ml
Shelf level: 2
1st burst of steam:
10 minutes after the start of the programme
2nd burst of steam:
after another 15 minutes
Duration: 40–45 minutes

Tip

For a nicely browned finish, turn the grill on shortly before the end of the cooking duration. Select Full grill, 240 °C for about 5–10 minutes.

Recipes

Marinated chicken thighs

Preparation time: 60–70 minutes + marinate for 2 hours

Serves 4–6

Ingredients

6 chicken thighs (300–400 g each)

Grated zest of 3 lemons

6 tbsp lemon juice

3 tbsp brown sugar

2 tsp salt

½ tsp pepper

4 tbsp oil

100 ml water

Accessories

Universal tray

Method

Mix together the lemon zest, lemon juice, sugar, salt, pepper and oil. Coat the chicken thighs all over with the resulting marinade, place them side by side in the universal tray, and leave for approx. 2 hours.

Baste the chicken again with the marinade, pour 100 ml water into the universal tray and place in the oven.

Setting

Oven function: Moisture plus 

Number/type of bursts of steam: 1

Temperature: 180–190 °C

Amount of water: approx. 100 ml

Shelf level: 2

1st burst of steam:

17 minutes after the start of the programme

Duration: 35–45 minutes

Tip

Individually spiced (not marinated) chicken thighs can also be cooked using the above settings. Simply add an additional 100 ml liquid to the universal tray at the start.

Turkey roulade with a spinach ricotta filling

Preparation time: 120–130 minutes

Serves 6

Ingredients

1000 g turkey breast
 1 shallot
 225 g frozen spinach, defrosted
 1 egg yolk
 16 g breadcrumbs
 125 g Ricotta
 Salt
 Pepper
 Nutmeg
 2 tbsp olive oil
 1 tsp rosemary
 750 ml chicken stock
 500 ml double cream

Accessories

Gourmet oven dish

Method

Finely dice the shallot and mix into the defrosted spinach along with the egg yolk and breadcrumbs. Season with salt, pepper and a little nutmeg.

Cut the turkey breasts lengthways but do not cut all the way through. Open out and flatten between two sheets of cling film. Season with salt and pepper and then spread the spinach-ricotta mixture over the top. Roll up and bind with kitchen string.

Season with salt and pepper and place in the Gourmet oven dish. Drizzle the roulades with olive oil and sprinkle the rosemary over the top. Add the stock and cook in the oven. After 60 minutes add the cream.

Take the roulades out of the sauce and remove the string. If necessary, thicken the sauce with a little cornflour mixed with water. Slice the roulades and serve with the sauce.

Setting

Oven function: Moisture plus 
 Number/type of bursts of steam: 3
 Temperature: 170–180 °C
 Amount of water: approx. 300 ml
 Shelf level: 2
 1st burst of steam:
 10 minutes after the start of the programme
 2nd burst of steam:
 after another 25 minutes
 3rd burst of steam:
 after another 25 minutes
 Duration: 90–100 minutes

Recipes

Turkey thighs

Preparation time: 60–120 minutes

Serves 3-4

Ingredients

1 turkey thigh on the bone (1100–1400 g)

Salt

Pepper

1 tbsp oil

500 ml water

Sauce

500 ml chicken stock

100 ml crème fraîche

2–3 tbsp cornflour

Salt

Pepper

Accessories

Gourmet oven dish

Method

Pierce the skin several times, season with salt and pepper and place skin side down in the Gourmet oven dish. Do not cover.

Brush the meat with oil, add the water and place in the pre-heated oven.

Remove the cooked meat from the Gourmet oven dish and keep warm in the oven. Add the stock to the Gourmet oven dish and bring to the boil on the hob. Add the cornflour mixed with a little water and the crème fraîche, bring briefly to the boil and season with salt and pepper.

Take the meat off the bone, cut up and serve with the sauce.

Setting

Oven function: Moisture plus 

Number/type of bursts of steam: 3

Temperature: 170–180 °C + pre-heating

Amount of water: approx. 300 ml

Shelf level: 2

1st burst of steam:

15 minutes after the start of the programme

2nd burst of steam:

after another 25 minutes

3rd burst of steam:

after another 25 minutes

Duration: 85–100 minutes

Tip

The nutritional values of poultry make it an important ingredient in a healthy diet. It is low in fat and high in protein, vitamins, minerals and trace elements such as iron.

Fillet of beef in a Port sauce

Preparation time: 60–120 minutes

Serves 6–8

Ingredients

1 whole fillet of beef (1500–1800 g)

2 tbsp clarified butter

Salt

Pepper

Sauce

800 ml beef stock

100 ml Port

40 ml Madeira

2 tbsp cornflour

Salt

Pepper

Sugar

Accessories

Large frying pan/Gourmet oven dish

Universal tray

Aluminium foil

Method

Trim the beef fillet, roll and secure with kitchen twine. Tie the thick end of the fillet tightly, tuck in approx. 10 cm at the thin end and tie, so the fillet is more or less uniformly thick. Season with salt and pepper.

Heat the clarified butter in the large frying pan/Gourmet oven dish on the hob on a high heat.

Sear the meat on all sides, then place on the universal tray and put it into the pre-heated oven.

Add the beef stock and Madeira to the meat juices in the frying pan/Gourmet oven dish and bring to the boil. Mix the Port and cornflour to a smooth paste,

add to the meat juices and bring to the boil. Season with salt, pepper and sugar.

Once cooked, wrap the fillet in aluminium foil and allow to rest for 10 minutes before carving.

Setting

Oven function: Moisture plus 

Number/type of bursts of steam: 3

Temperature: 140–150 °C + pre-heating

Amount of water: approx. 200 ml

Shelf level: 2

1st burst of steam:

5 minutes after the start of the programme

2nd burst of steam:

after another 15 minutes

Duration:

25–35 minutes (“Fillet of beef - rare”)

40–50 minutes (“Fillet of beef - medium”)

65–80 minutes (“Fillet of beef - well-done”)

Recipes

Braised beef roulades

Preparation time: 155–165 minutes

Serves 4

Ingredients

4 thin beef steaks (approx. 160–200 g each)

Salt

Pepper

4 tsp medium-hot mustard

8 slices of streaky bacon

8 cocktail gherkins (cornichons)

2 carrots

1 thin leek

150 g celery

1 onion

Oil

1 tbsp tomato paste

250 ml red wine

2 sprigs of thyme

2 sprigs of rosemary

2 bay leaves

1 clove of garlic

1000 ml beef stock

100 ml double cream

Accessories

Gourmet oven dish

Gourmet oven dish lid

Method

Lay the steaks out next to each other and season with salt and pepper. Coat with mustard and then top each with 2 slices of bacon and 2 gherkins cut into batons. Roll up and secure with wooden skewers or kitchen twine. Dice the carrots, leek, celery and onions (into 1 cm pieces).

Heat the oil in a Gourmet oven dish and sear the roulades all round. Remove and then fry the vegetables.

Add the tomato purée and cook with the vegetables. Deglaze with a third of the red wine. When the wine is almost fully reduced add the next third and so on until the wine is totally reduced.

Add the herbs, spices and garlic together with the stock. Put the roulades back into the oven dish, cover and cook in the oven for 60 minutes.

Remove the lid after 60 minutes in the oven and release the first burst of steam. Continue cooking without the lid.

When done, take the roulades out and remove the skewers or the kitchen twine. Sieve the stock, add the cream and if necessary thicken the sauce with a little cornflour mixed with water.

Setting

Oven function: Moisture plus 

Number/type of bursts of steam: 3

Temperature: 140 °C

Amount of water: approx. 300 ml

Shelf level: 2

1st burst of steam:

60 minutes after the start of the programme

2nd burst of steam:

after another 20 minutes

3rd burst of steam:

after another 20 minutes

Duration: 120 minutes

Recipes

Braised silverside of veal

Preparation time: 120–130 minutes

Serves 8

Ingredients

1500 g silverside of veal

2 carrots

1 thin leek

150 g celery

1 onion

1 clove of garlic

2 sprigs of thyme

2 sprigs of rosemary

4 bay leaves

5 juniper berries

Salt

Pepper

500 ml white wine

100 g crème fraîche

250 ml beef stock or water

Setting

Oven function: Moisture plus 

Number/type of bursts of steam: 3

Temperature: 210–220 °C

After 20 minutes: 140–150 °C

Amount of water: approx. 300 ml

Shelf level: 2

1st burst of steam:

10 minutes after the start of the programme

2rd burst of steam:

after another 15 minutes

3rd burst of steam:

after another 30 minutes

Duration: 90–100 minutes

Accessories

Gourmet oven dish

Method

Dice the carrots, the leek and the onions (1 cm) and place in the Gourmet oven dish together with the garlic, the herbs and the spices.

Season the meat with salt and pepper and place on top of the vegetables and cook.

After 20 minutes cooking, deglaze with the white wine, reduce the temperature and cook the meat until done. Add water as necessary if the vegetables get too dry.

Sieve the sauce then thicken with crème fraîche and stock. Use a little cornflour mixed with water if necessary.

Glazed gammon

Preparation time: 85–105 minutes

Serves 6

Ingredients

1000 g gammon joint
20 g softened butter
40 g brown sugar
2 carrots
1 thin leek
150 g celery
1 onion
5 bay leaves
6 cloves
10 crushed juniper berries
125 ml red wine
250 ml water

Accessories

Universal tray

Method

Score the surface of the gammon in a criss-cross pattern about 2-3 mm deep. Rub butter and sugar into the cuts.

Dice the carrots, the leek, the celery and the onion (1 cm). Mix with the spices and place in the centre of the universal tray. Place the gammon joint on top. Pour the red wine and water around the gammon and cook in the oven, adding a little water if the vegetables become too dry.

Sieve the juices and thicken with a little cornflour mixed with water if necessary. Slice the gammon and serve with the gravy.

Setting

Oven function: Moisture plus 
Number/type of bursts of steam: 3
Temperature: 150–160 °C
Amount of water: approx. 300 ml
Shelf level: 2
1st burst of steam:
5 minutes after the start of the programme
2nd burst of steam:
after another 10 minutes
3rd burst of steam:
after another 30 minutes
Duration: 70–90 minutes

Recipes

Stuffed pork tenderloin

Preparation time: 65–75 minutes

Serves 6

Ingredients

4 pork tenderloin (300 g each)

Salt

Pepper

20 basil leaves

250 g red pesto

30 g Parmesan, freshly grated

12 slices of Parma ham

40 g butter

250 ml double cream

250 ml meat stock

Accessories

Gourmet oven dish

Method

Cut the pork along the length, but not right through. Season both sides with salt and pepper and then arrange the basil leaves along the cut edge.

Spread the red pesto over the meat and then sprinkle with parmesan. Fold the two halves together and wrap with the Parma ham. Place in a Gourmet oven dish, dot with butter and place in the oven.

After 15 minutes in the oven add the cream and the stock. Reduce the temperature to 140 °C and release the last burst of steam. If wished the sauce can be thickened with a little cornflour mixed with water.

Setting

Oven function: Moisture plus 

Number/type of bursts of steam: 2

Temperature: 170–180 °C

After 15 minutes: 140 °C

Amount of water: approx. 200 ml

Shelf level: 2

1st burst of steam:

5 minutes after the start of the programme

2nd burst of steam:

after another 10 minutes

Duration: 35–45 minutes

Tip

To make your own red pesto: Finely dice 200 g of bottled sundried tomatoes and a clove of garlic. Purée with 50 ml of olive oil, 1 tsp sugar and 2 tbsp breadcrumbs. Season to taste with a little oregano and Sambal Oelek.

Pork casserole with apples

Preparation time: 60–70 minutes

Serves 6–8

Ingredients

1200 g pork fillet
4 apples
400 ml double cream
150 g tomato sauce
4 tbsp curry powder
3 tbsp cornflour
Salt
Pepper

Topping

150 g grated Cheddar cheese

Accessories

Gourmet oven dish/Shallow ovenproof dish

Method

Cut the pork fillet into in 3 cm thick slices and season with salt and pepper. Peel, core and cut the apples into six pieces.

Arrange the meat and apples in layers in the Gourmet oven dish or in an ovenproof dish without a lid.

Make the sauce by combining the cream, tomato sauce, curry powder, cornflour, salt and pepper.

Pour the sauce over the meat and the apples, sprinkle the cheese on top and place in the pre-heated oven.

Setting

Oven function: Moisture plus 

Number/type of bursts of steam: 1

Temperature: 170–180 °C + pre-heating

Amount of water: approx. 100 ml

Shelf level: 2

1st burst of steam:

after placing food in the oven

Duration: 40–45 minutes

Recipes

Spare ribs

Preparation time: 60 minutes
plus: 3–4 hours marinating

Ingredients

1500 g pork blade roast
3–4 cloves of garlic
2 walnut sized pieces of fresh ginger
3 tsp salt
3 tsp soy sauce
3 tsp honey
2 tbsp sherry
1 tsp five spice powder
2 tbsp hoi sin sauce
Sambal Oelek

Accessories

Rack
Universal tray

Method

Finely dice the garlic, peel and grate the ginger. Mix well with the salt, soy sauce, honey, sherry, five spice powder and hoi sin sauce. Season to taste with Sambal Oelek.

Cut the meat in slices approx. 3 cm thick. Place in an airtight container, pour the marinade over and close the container. Place in the refrigerator to marinate for about 3–4 hours, turning from time to time.

Take the meat out of the marinade and place on a rack fitted above the universal tray. Place in a pre-heated oven and release the burst of steam immediately.

Setting

Oven function: Moisture plus 
Number/type of bursts of steam: 1
Temperature: 170–180 °C + pre-heating
Amount of water: approx. 100 ml
Shelf level: 2
1st burst of steam:
after placing food in the oven
Duration: 20–30 minutes

Spanish garlic rabbit

Preparation time: approx. 130 minutes

Serves 4

Ingredients

1 rabbit
Salt
Pepper
4 celery sticks
2 onions
2 tomatoes
4 cloves of garlic
5 tbsp olive oil
125 ml white wine
750 ml chicken stock
3 sprigs of thyme
4 bay leaves
100 g black olives, sliced

Accessories

Gourmet oven dish

Method

Cut the rabbit into 6 pieces and season with salt and pepper. Dice the celery, onions and tomatoes (1 cm pieces).

Place the meat in a Gourmet oven dish and sear in olive oil on the hob. Add the tomatoes, celery, onions and garlic and fry gently for approx. 5 minutes.

Deglaze with the white wine and add the chicken stock, thyme, bay leaves and sliced olives. Place in the oven and cook uncovered.

Remove the meat, sieve the sauce into a pan and simmer. Thicken with a little cornflour mixed in water if necessary.

Setting

Oven function: Moisture plus 
Number/type of bursts of steam: 2
Temperature: 150–160 °C
Amount of water: approx. 200 ml
Shelf level: 2
1st burst of steam:
10 minutes after the start of the programme
2nd burst of steam:
after another 20 minutes
Duration: 70–80 minutes

Tip

This Spanish recipe is usually served with flat bread and a seasonal salad.

Recipes

Saddle of roebuck

Preparation time: 70–80 minutes

Serves 4–8

Ingredients

1 saddle of venison on the bone (1000–3000 g)

80–100 g sliced streaky bacon

Salt

Pepper

Sauce

1 onion

2 carrots

50 g celery

100 ml red wine

500 ml stock

20 g butter

1 tbsp plain flour

1 tbsp tomato paste

50 ml double cream

1 tsp rosemary

Salt

Pepper

Sugar

Accessories

Universal tray

Saucepan

Method

Remove fat and any silverskin membrane from the meat and put these to one side. Season with salt and pepper and place in the universal tray.

Cover the roebuck with the bacon slices and place in the pre-heated oven.

Fry the offcuts in oil. Dice carrots, onions and celery and add to the pan. Add tomato purée, rosemary and 100 ml red wine and bring to the boil. Add the stock to this and allow to simmer for 20 minutes. Pass the resulting stock through a sieve.

Heat the butter in a pan and add the flour. Add the stock gradually and bring to the boil. Add cream and season with salt, pepper, sugar and rosemary.

Remove the meat from the bone. To do this, cut firmly along the ribs from the middle upwards. This is best done with a sharp, pointed knife. Slice the resulting pieces into medallions and serve with the sauce.

Setting

Oven function: Moisture plus 

Number/type of bursts of steam: 1

Temperature: 190-200 °C + pre-heating

Amount of water: approx. 200 ml

Shelf level: 2

1st burst of steam:

10 minutes after the start of the programme

2nd burst of steam:

after another 10 minutes

Duration: 35–45 minutes

Tip

For a 2–3 kg saddle of roebuck, the sauce quantity should be doubled.

Recipes

Lamb in a thyme and mustard sauce

Preparation time: 60–120 minutes

Serves 4–6

Ingredients

1 saddle of lamb on the bone (1.7 - 2.5 kg)

1 tsp dried thyme

Salt

Pepper

2 tbsp oil

Sauce

1 onion

400 ml lamb stock

20 g butter

20 g plain flour

3–4 tbsp mustard

100 ml double cream

1 tsp dried thyme

Salt

Pepper

Sugar

Accessories

Universal tray

Saucepan

Method

Remove the layer of fat from the lamb and season with salt, pepper and thyme.

Place the lamb in the universal tray and brush with oil. Then place in the pre-heated oven.

Fry the onions and thyme in butter. Dust with flour and add the lamb stock. Add the mustard and cream. Bring the sauce to the boil and season with salt, pepper and sugar.

De-bone the saddle of lamb. To do this, cut firmly along the ribs from the middle upwards. This is best done with a sharp, pointed knife. Slice the resulting pieces into medallions and serve with the sauce.

Setting

Oven function: Moisture plus 

Number/type of bursts of steam: 2

Temperature: 210–220 °C + pre-heating

Amount of water: approx. 200 ml

Shelf level: 2

1st burst of steam:

15 minutes after the start of the programme

2nd burst of steam:

after another 12 minutes

Duration: 45–55 minutes

Potato dumplings

Preparation time: 125–155 minutes

Serves 4

Ingredients

125 g potatoes

½ cube of fresh yeast (21 g)

80 ml lukewarm milk

½ tsp salt

250 g flour

20 g softened butter

1 egg

200 g cream cheese with herbs

For glazing

Milk

Accessories

Ovenproof dish, approx. 20 x 30 cm

Method

Peel and cook the potatoes and pass them through a potato ricer whilst still warm, then leave to cool.

Dissolve the yeast in lukewarm milk. Then add potatoes, salt, flour, butter and egg and knead until you get a smooth pliable dough. Cover and place in the oven for about 25–35 minutes to prove using Conventional heat at 35 °C.

Form 12 small balls, make a small well in the side of each, fill with 1 tsp cream cheese and press back together to seal.

Place the dumplings in the greased oven-proof dish with the seam underneath. Cover and place in the oven to prove for another 20–25 minutes using Conventional heat at 35 °C.

Brush the dumplings with milk and bake until golden.

Setting

Oven function: Moisture plus 

Number/type of bursts of steam: 2

Temperature: 160–170 °C

Amount of water: approx. 200 ml

Shelf level: 2

1st burst of steam:

5 minutes after the start of the programme

2nd burst of steam:

after another 10 minutes

Duration: 35–45 minutes

Tip

Dumplings can also be served as a side dish with sliced meat and salad.

Recipes

Cheese soufflés

Preparation time: 60–65 minutes

Serves 8

Ingredients

20 g butter

30 g flour

200 ml hot milk

Salt

Freshly ground pepper

1 pinch of ground nutmeg

1 pinch of cayenne pepper
1 pinch of cayenne pepper

4 egg yolks

120 g grated cheese

4 egg whites

Breadcrumbs

2 tbsp grated Parmesan cheese

Accessories

Saucepan

8 ramekins

Universal tray

Method

Melt the butter in a saucepan and stir in the flour (do not allow to brown). Stir in the milk and simmer gently for approx. 5 minutes. Season with salt, pepper, nutmeg and cayenne pepper.

Stir in the egg yolk a little at a time, then add the cheese.

Whisk the egg whites until stiff and carefully add to the cooled cheese sauce.

Sprinkle the buttered ramekins with breadcrumbs and fill them with the soufflé mixture to within 1 cm of the top. Sprinkle with Parmesan.

Place the ramekins on the universal tray and bake in the preheated oven, releasing the burst of steam immediately.

Setting

Oven function: Moisture plus 

Number/type of bursts of steam: 1

Temperature: 180–190 °C + pre-heating

Amount of water: approx. 100 ml

Shelf level: 2

1st burst of steam:

after placing food in the oven

Duration: 20–25 minutes

Tip

Serve the soufflés immediately to prevent them from collapsing.

Spring pie

Preparation time: 100–110 minutes

Serves 4

Ingredients

300 g puff pastry
1 red pepper
1 yellow pepper
3 spring onions
1000 g minced beef
1 garlic clove, finely chopped
100 g breadcrumbs
2 eggs
Salt
Freshly ground pepper
Paprika powder
2 tsp medium-hot mustard

For glazing

1 egg yolk
Water

Accessories

Loaf tin, 30 cm long

Method

Dice the peppers and slice the spring onion.

Mix the minced beef with the vegetables, garlic, breadcrumbs, eggs, spices and mustard.

Grease and line a loaf tin with baking parchment. Roll the pastry out to approx. 45 cm x 50 cm. Line the tin with the pastry, leaving the same amount of pastry hanging over the sides all round. Add the minced beef mixture and press down firmly. Use the overlapping pastry to form a lid. Coat the edges with water and press the edges to seal the pie.

Cut 3 diamonds, approx. 3 x 3 cm in size out of the lid and use them to decorate the top of the pie.

Whisk the egg yolk with some water, brush over the pastry and bake.

Setting

Oven function: Moisture plus 

Number/type of bursts of steam: 2

Temperature: 180–190 °C

Amount of water: approx. 200 ml

Shelf level: 2

1st burst of steam:

20 minutes after the start of the programme

2nd burst of steam:

after another 15 minutes

Duration: 55–65 minutes

Recipes

Cheese pie

Preparation time: 130–140 minutes

Serves 8

Dough ingredients

1 cube of fresh yeast (42 g)

150 ml lukewarm milk

150 g rye flour

200 g strong white flour

30 g butter

½ tsp salt

½ tsp sugar

Filling ingredients

300 g cheese

2 small red peppers

2 small red onions

2 tbsp chives, chopped

Salt

Coarsely ground black pepper

Chilli powder

To sprinkle on top

4 tbsp pumpkin seeds

Accessories

Ovenproof dish, approx. 20 x 30 cm

Method

Dissolve the yeast in lukewarm milk. Then add to the remaining ingredients and knead until you get a smooth pliable dough. Cover and place in the oven for about 40–50 minutes to prove using Conventional heat at 35 °C.

Finely dice the cheese. Dice the peppers and onions and mix with the chopped chives. Season with salt, pepper and chilli powder.

Roll the dough out onto a floured surface into a square (approx. 40 x 40 cm). Drape over a greased shallow

square dish (approx. 20 x 20 cm) with the corners offset. Place the filling on the dough and fold the edges up over the filling, pressing them together to seal. Cut 5 diamonds (approx. 3 x 3 cm) out of the lid and use them to decorate the top of the pie.

Brush with water and scatter pumpkin seeds over the top. Bake until golden and leave to stand for about 30 minutes before serving.

Setting

Oven function: Moisture plus 

Number/type of bursts of steam: 3

Temperature: 170–180 °C

Amount of water: approx. 300 ml

Shelf level: 2

1st burst of steam:

5 minutes after the start of the programme

2nd burst of steam:
after another 10 minutes

3rd burst of steam:
after another 10 minutes

Duration: 50–60 minutes

Tip

The pie is very good as a starter or as a light main together with a salad.

Tortellini, ham and rocket bake

Preparation time: 50–60 minutes

Serves 6

Ingredients

125 g rocket
100 g air-dried ham
300 ml double cream
400 g soured cream
Salt
Pepper
800 g fresh tortellini
300 g cherry tomatoes, halved
4 tbsp pine nuts, roasted
50 g Parmesan cheese, freshly grated
50 g Emmental cheese, coarsely grated

Accessories

Ovenproof dish, approx. 20 x 30 cm

Method

Wash and pat dry the rocket and cut up into strips, along with the ham. Mix the cream and soured cream and season with salt and pepper.

Mix the tortellini with the halved tomatoes, rocket and ham, place in the greased ovenproof dish and top with the sauce.

Sprinkle with pine nuts and cheese and bake until golden.

Setting

Oven function: Moisture plus 
Number/type of bursts of steam: 2
Temperature: 170–180 °C
Amount of water: approx. 200 ml
Shelf level: 2
1st burst of steam:
10 minutes after the start of the programme
2nd burst of steam:
after another 10 minutes
Duration: 40–50 minutes

Recipes

Mushroom cannelloni

Preparation time: 75–85 minutes

Serves 4

Ingredients

16 cannelloni

Filling ingredients

1 onion

100 g cooked ham

350 g button mushrooms

2 tbsp oil

75 g goats' cheese

100 g Mozzarella

150 g cream cheese

Salt

Pepper

300 ml stock

100 g soured cream

Topping

100 g grated cheddar cheese

Accessories

Frying pan

Ovenproof dish, approx. 25 x 30 cm

Method

Dice the onion, ham and mushrooms. Heat the oil in a pan and gently fry the onion. Add the ham and continue to fry for a short while. Add the mushrooms and fry until there is no water in the pan.

Dice the goats' cheese and mozzarella. Add the cooled mushroom mixture and cream cheese and mix well. Season with salt and pepper to taste.

Fill the cannelloni with the mixture and place in the greased ovenproof dish.

Mix the soured cream into the stock and pour over the cannelloni. Sprinkle with cheese and bake until golden.

Setting

Oven function: Moisture plus 

Number/type of bursts of steam: 2

Temperature: 170–180 °C

Amount of water: approx. 200 ml

Shelf level: 2

1st burst of steam:

10 minutes after the start of the programme

2nd burst of steam:

after another 10 minutes

Duration: 45–55 minutes

Tip

The cannelloni are easier to fill if you use a piping bag without a nozzle.

Potato cheese bake

Preparation time: 85–95 minutes

Serves 4

Ingredients

500 g peeled, floury potatoes

250 ml double cream

125 g crème fraîche

150 g grated Cheddar cheese

1 clove of garlic

Salt

Black pepper

Nutmeg

Accessories

Saucepan

Ovenproof dish, shallow Ø 30 cm

Method

Slice the potatoes thinly and parboil in salted water for about 5 minutes.

Place the potatoes in the greased shallow greased ovenproof dish which has been rubbed with a garlic clove.

Mix with 2/3 of the cheese.

Blend together the cream, crème fraîche, salt, pepper and nutmeg and pour evenly over the potatoes. Scatter the rest of the cheese over the top and place in the oven.

Setting

Oven function: Moisture plus 

Number/type of bursts of steam: 2

Temperature: 170–180 °C

Amount of water: approx. 100 ml

Shelf level: 2

1st burst of steam:

15 minutes after the start of the programme

Duration: 40–50 minutes

Tip

For a low-calorie variation, arrange 750 g sliced potatoes in an ovenproof dish. Season with salt and pepper, and pour over 250 ml of vegetable stock. Bake as above. About 10 minutes before the end of baking, scatter 3 tbsp grated Parmesan over the top.

Recipes

Lasagne

Preparation time: 110–120 minutes

Ingredients

10 (approx. 180 g) sheets of lasagne, not pre-cooked

Ingredients for the meat sauce

50 g smoked streaky bacon, finely diced

150 g onions

375 g minced beef

Salt

Black pepper

1 tsp thyme

1 tsp oregano

1 tsp basil

500 g skinned tomatoes

3 tbsp tomato purée

125 ml stock

Ingredients for the mushroom sauce

20 g butter

150 g fresh mushrooms, sliced

2 tbsp plain flour

250 ml double cream

250 ml milk

Salt

Nutmeg

2 tbsp parsley, chopped

Topping

200 g grated cheddar cheese

Accessories

Frying pan

Saucepan

Ovenproof dish, approx. 25 x 30 cm

Method

Gently fry the bacon with 2/3 of the onion. Add the minced beef, and fry until brown all over, turning frequently. Season with salt, pepper and herbs. Chop the tomatoes coarsely, and stir into the meat together with the tomato purée and the stock. Simmer for approx. 5 minutes.

To make the mushroom sauce, melt the butter in a pan on the hob, and fry the rest of the onions until golden. Add the sliced mushrooms and lightly fry. Sprinkle in the flour a little at a time, stirring constantly. Stir in the cream and milk gradually to make a smooth sauce, season, and cook for approx. 5 minutes, continuing to stir. Add the parsley.

Grease the oven-proof dish. Add 1/3 of the tomato-meat sauce, followed by 5 of the lasagne sheets, then 1/3 of the tomato-meat sauce, half of the mushroom sauce, 5 lasagne sheets, the remainder of the tomato-meat sauce and finally the remainder of the mushroom sauce.

Sprinkle with grated cheese, then bake uncovered in the oven.

Setting

Oven function: Moisture plus 

Number/type of bursts of steam: 2

Temperature: 160–170 °C

Amount of water: approx. 200 ml

Shelf level: 2

1st burst of steam:

12 minutes after the start of the programme

2nd burst of steam:

after another 25 minutes

Duration: 45–55 minutes

Recipes

Dumplings with plum compote

Preparation time: 105–115 minutes

Serves 6

Ingredients

500 g strong white flour
1 cube of fresh yeast (42 g)
50 g sugar
250 ml lukewarm milk
1 tsp ground cinnamon
A pinch of salt
100 g softened butter
1 egg
120 g plum compote

For dusting

40 g icing sugar

Accessories

Ovenproof dish, approx. 20 x 30 cm

Method

Dissolve the yeast in lukewarm milk. Then add to the flour, sugar, salt, butter and egg and knead until you get a smooth dough. Cover and place in the oven to prove for 20–30 minutes using Conventional heat at 35 °C.

Make 12 balls from the dough. Open them enough to fill with 1 tbsp of plum compote and then seal them up. Place with the sealed edge underneath in the greased oven dish.

Cover and allow to prove in the oven for 20 minutes using Conventional heat at 35 °C. Bake until golden.

Dust with icing sugar and serve them with vanilla custard.

Setting

Oven function: Moisture plus 
Number/type of bursts of steam: 2
Temperature: 150–160 °C
Amount of water: approx. 200 ml
Shelf level: 2
1st burst of steam:
5 minutes after the start of the programme
2nd burst of steam:
after another 10 minutes
Duration: 35–45 minutes

Tip

As an alternative try filling the dumplings with a halved plum and a sprinkling of sugar and a sprinkling of sugar.

Sweet cherry soufflé

Preparation time: 40–50 minutes

Serves 8

Ingredients

Butter

50 g ground nuts

200 g sour cherries

2 egg yolks

80 g icing sugar

Pulp of 1 vanilla pod

250 g quark

20 g cornflour

2 egg whites

For dusting

40 g icing sugar

Accessories

8 ramekins, Ø 7–8 cm

Universal tray

Method

Grease the ramekins with butter and dust with the ground nuts.

Drain the cherries and spoon into the ramekins.

Beat the egg yolk with 60 g of icing sugar until light and fluffy. Stir in the vanilla pulp, quark and cornflour. Beat the egg white to stiff peaks with the rest of the icing sugar and carefully fold into the mixture.

Spoon the mixture into the ramekins, arrange on the universal tray and then place in the pre-heated oven. Pour approx. 1 litre of warm water into the universal tray to make a bain marie then bake the ramekins.

Dust with icing sugar before serving.

Setting

Oven function: Moisture plus 

Number/Type of bursts of steam:
Automatic

Temperature: 170–180 °C

Amount of water: approx. 100 ml

















Shelf level: 2





1st burst of steam: automatic

Duration: 20–30 minutes

Note for test institutes

Test food acc. to EN 60350-1

Test food	Accessories		 [°C]	 ⁵ ₁	 [min]	Pre-heat
Drop cookies	1 tray		140	2	30–40	No
			160 ⁴⁾	3	20–30	Yes
	2 trays ¹⁾		140	1+3	35–45	No
Small cakes	1 tray		150	2	25–40	No
			160 ⁴⁾	3	20–30	Yes
	2 trays		150 ⁴⁾	2+4	25–35	Yes
Whisked sponge	Springform ²⁾ ∅ 26 cm		180	2	20–30	No
		 ³⁾	150–170 ⁴⁾	2	20–45	Yes
Apple cake	Springform ²⁾ ∅ 20 cm		160	2	90–100	No
			180	1	85–95	No
Toast	Rack		300	3	5–8	No
Burgers	Rack on top of universal tray		300	4	1st side: 7– 12 2nd side: 5–12	Yes, 5 minutes

 Function /  Temperature / ⁵₁ Shelf level /  Cooking duration

 Fan plus /  Conventional heat /  Grill

- 1) Take the baking trays out of the oven early if the food is sufficiently browned before the specified duration has elapsed.
- 2) Use a dark coloured, matt tin and place it on the rack.
- 3) In general, if a range of temperatures is given, it is best to select the lower temperature and to check the food after the shortest duration.
- 4) Pre-heat the oven. Do not use Rapid heat-up .

Energy efficiency class

The energy efficiency class is calculated in accordance with EN 60350-1.

Energy efficiency class: A+

Please observe the following advice when testing:

- Use the Gentle bake  programme for testing purposes.
- Set the oven lighting to “On for 15 seconds” (see “Settings”).
- During testing make sure that only those accessories required for the test are in the oven cavity.
Do not use other accessories that might be available, such as FlexiClip runners or catalytic enamelled panels such as side panels or roof liners.
- When calculating the Energy efficiency class it is important to keep the oven door firmly closed.
Depending on test instruments used, the door seal function can be affected to a greater or lesser degree. This can have a negative influence on test results.
This can be compensated for by pressing on the door. Where necessary suitable technical measures can be used to assist. The door seal is not affected in normal everyday use.

Data sheets for household ovens

The data sheets apply to models described in this operating instruction manual.

Note for test institutes

Data sheet for household ovens

In acc. with delegated regulation (EU) No. 65/2014 and regulation (EU) No. 66/2014

MIELE	
Model name / identifier	H6160BP
Energy efficiency index/cavity (EEI _{cavity})	81,9
Energy efficiency class/cavity	
A+++ (most efficient) to D (least efficient)	A+
Energy consumption per cycle for each cavity in conventional mode	1,10 kWh
Energy consumption per cycle for each cavity in fan-forced convection mode	0,71 kWh
Number of cavities	1
Heat source(s) per cavity	electric
Volume of cavity	76 l
Mass of the appliance	47,0 kg

Data sheet for household ovens

In acc. with delegated regulation (EU) No. 65/2014 and regulation (EU) No. 66/2014

MIELE	
Model name / identifier	H6260BP
Energy efficiency index/cavity (EEI _{cavity})	81,9
Energy efficiency class/cavity	
A+++ (most efficient) to D (least efficient)	A+
Energy consumption per cycle for each cavity in conventional mode	1,10 kWh
Energy consumption per cycle for each cavity in fan-forced convection mode	0,71 kWh
Number of cavities	1
Heat source(s) per cavity	electric
Volume of cavity	76 l
Mass of the appliance	47,0 kg



United Kingdom

Miele Co. Ltd.
Fairacres, Marcham Road
Abingdon, Oxon, OX14 1TW
Tel: 0330 160 6600
Internet: www.miele.com

Australia

Miele Australia Pty. Ltd.
ACN 005 635 398
ABN 96 005 635 398
1 Gilbert Park Drive
Knoxfield, VIC 3180
Tel: 1300 464 353
Internet: www.miele.com.au

China

Miele (Shanghai) Trading Ltd.
1-3 Floor, No. 82 Shi Men Yi Road
Jing' an District
200040 Shanghai, PRC
Tel: +86 21 6157 3500
Fax: +86 21 6157 3511
E-mail: info@miele.cn
Internet: www.miele.cn

Miele (Hong Kong) Limited

41/F - 4101, Manhattan Place
23 Wang Tai Road
Kowloon Bay, Hong Kong
Tel: (852) 2610 1025
Fax: (852) 3579 1404
Email:
customerservices@miele.com.hk
Website: www.miele.hk

India

Miele India Pvt. Ltd.
Ground Floor
Copia Corporate Suites
Plot No. 9, Jasola
New Delhi - 110025
Tel: 011-46 900 000
Fax: 011-46 900 001
E-mail: customercare@miele.in
Internet: www.miele.in

Ireland

Miele Ireland Ltd.
2024 Bianconi Avenue
Citywest Business Campus
Dublin 24
Tel: (01) 461 07 10
Fax: (01) 461 07 97
E-Mail: info@miele.ie
Internet: www.miele.ie

Malaysia

Miele Sdn Bhd
Suite 12-2, Level 12
Menara Sapura Kencana
Petroleum
Solaris Dutamas No. 1
Jalan Dutamas 1
50480 Kuala Lumpur, Malaysia
Phone: +603-6209-0288
Fax: +603-6205-3768

New Zealand

Miele New Zealand Limited
IRD 98 463 631
Level 2, 10 College Hill
Freemans Bay, Auckland 1011
New Zealand
Tel: 0800 464 353
Internet: www.miele.co.nz

Singapore

Miele Pte. Ltd.
163 Penang Road
04 - 03 Winsland House II
Singapore 238463
Tel: +65 6735 1191
Fax: +65 6735 1161
E-Mail: info@miele.com.sg
Internet: www.miele.sg

South Africa

Miele (Pty) Ltd
63 Peter Place, Bryanston 2194
P.O. Box 69434, Bryanston 2021
Tel: (011) 875 9000
Fax: (011) 875 9035
E-mail: info@miele.co.za
Internet: www.miele.co.za

Taiwan

K.E. & Kingstone Co., Ltd.
6th Fl., No. 120, Sec. 2
Jianguo N. Rd.
Taipei, Taiwan
TEL: +886 2 2502-7256
FAX: +886 2 2502-3077
E-mail: kenk@kenk.com.tw
Website:
www.kenk.com.tw/ke/miele

Thailand

BHIRAJ TOWER at EmQuartier
43rd Floor Unit 4301-4303
689 Sukhumvit Road
North Klontong Sub-District
Vadhana District
Bangkok 10110, Thailand

United Arab Emirates

Miele Appliances Ltd.
Gold & Diamond Park
Office No. 6-217
Sheikh Zayed Road
P.O. Box 11 47 82 - Dubai
Tel. +971 4 3044 999
Fax. +971 4 3418 852
800-MIELE (64353)
E-Mail: info@miele.ae
Website: www.miele.ae

Manufacturer: Miele & Cie. KG, Carl-Miele-Straße 29, 33332 Gütersloh, Germany

H6160BP, H6260BP