

# Montpellier

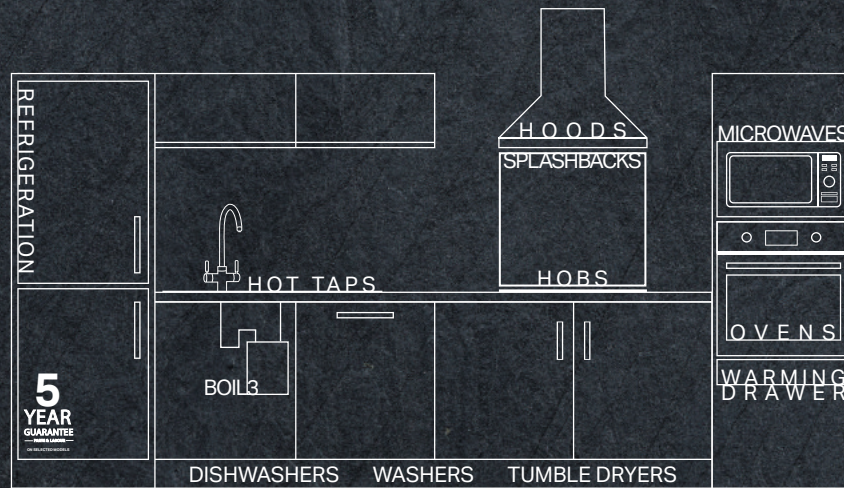

**Built-In Range |** The perfect balance of function & style.

# Why Montpellier?

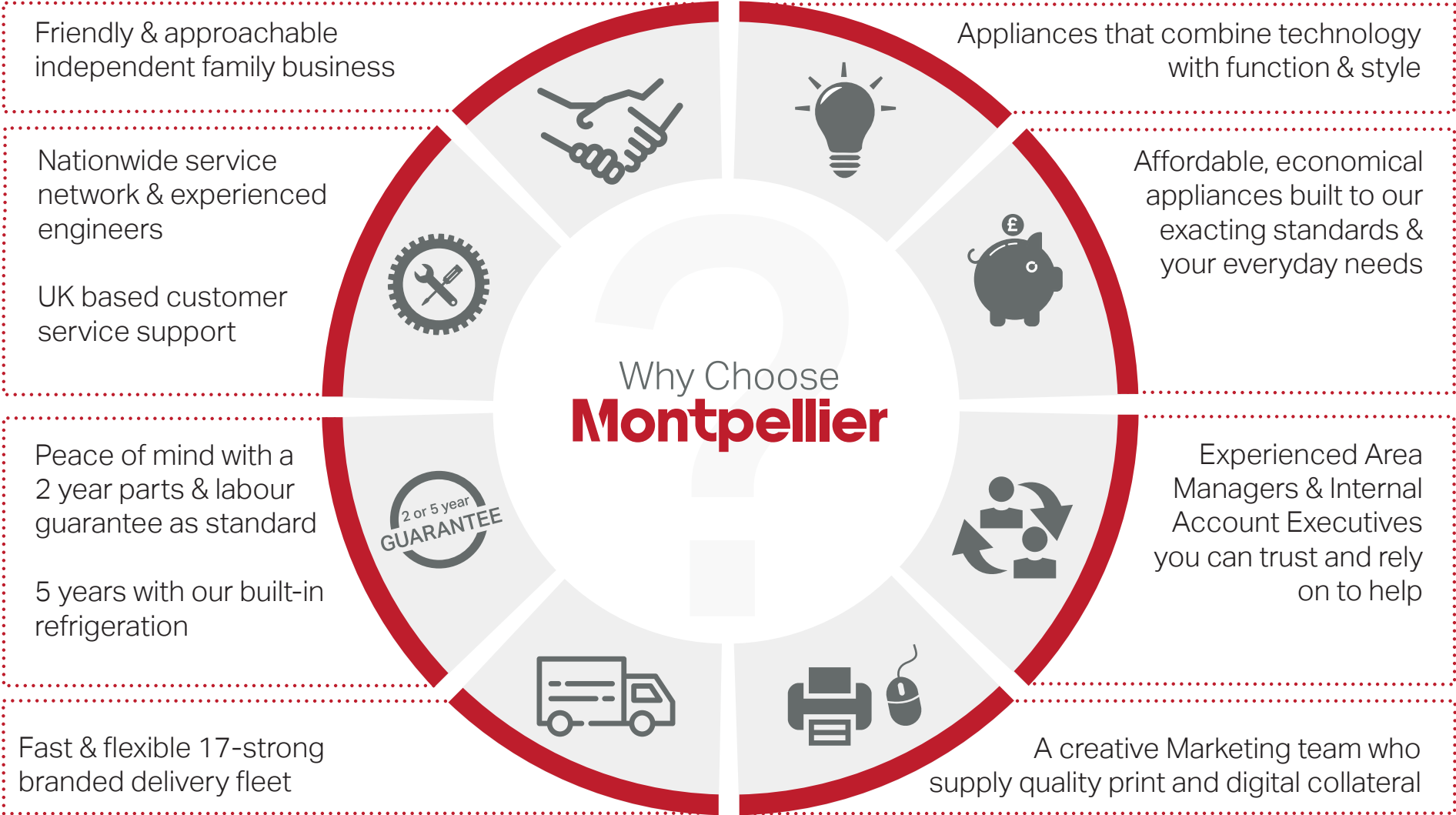

# Contents

---

**Laundry** 3 - 5

---

**Dishwashing** 6 - 8

---

**Cooking** 9 - 42

---

Ovens 9 - 15

---

Hobs 16 - 26

---

Microwaves & Warming Drawer 27 - 29

---

Hoods 30 - 41

---

Splash Backs 42

---

**Cooling** 43 - 50

---

**Accessories** 51 - 54

---

**Icon Guide** 55

---

**Contact Us** 56

---

# Built-In Laundry |



## MWBI6012\* Built-In Washing Machine

### Key Features:

- > 6Kg Capacity
- > 1200RPM
- > 18 Programmes
- > 30 Min Quick Wash
- > LED Indicator Lights
- > Dial Control
- > Variable Temperature



**Annual Energy Consumption:** 176kWh  
**Annual Water Consumption:** 9272Ltr  
**Dimensions:** H820 W595 D580mm

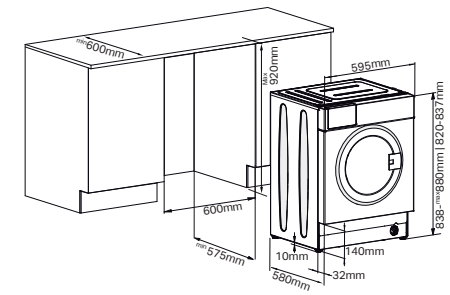

## MWBI7021 Built-In Washing Machine

### Key Features:

- > 7Kg Capacity
- > 1200RPM
- > 15 Programmes
- > 28 Min Quick Wash (on a 7kg load)
- > LED Display
- > Dial & Button Control
- > Drum Clean Function



**Annual Energy Consumption:** 173kWh  
**Annual Water Consumption:** 9899Ltr  
**Dimensions:** H820 W597 D554mm

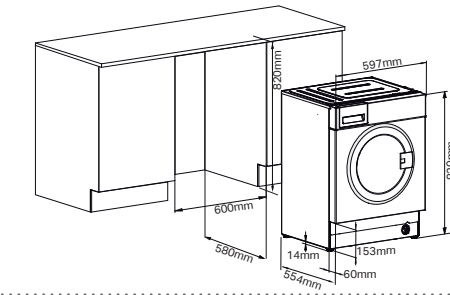

## MWBI8014 Built-In Washing Machine

### Key Features:

- > 8Kg Capacity
- > 1400RPM
- > 15 Programmes
- > 30 Min Quick Wash
- > 24hr Delay Start
- > Dial & Button Control
- > Perfect 59 min. Rapid Wash



**Annual Energy Consumption:** 196kWh  
**Annual Water Consumption:** 9850Ltr  
**Dimensions:** H820 W596 D570mm

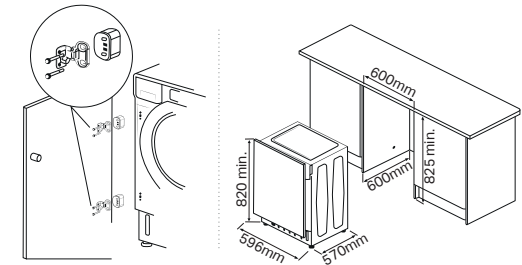

# Built-In Laundry |



## MWDI7555 Built-In Washer Dryer

### Key Features:

- > 7.5+5Kg Capacity
- > 1400RPM
- > 13 Wash Programmes
- > 3 Drying Programmes
- > Rapid Wash
- > Start Delay
- > LED Display



**Annual Energy Consumption:** 208kWh  
**Annual Water Consumption:** 9800Ltr  
**Dimensions:** H820 W596 D570mm

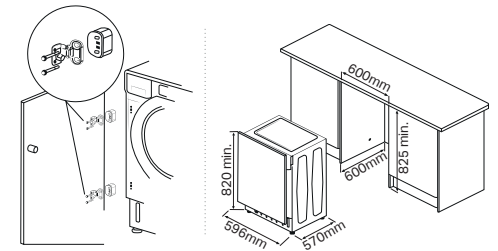

## MTDI7S Built-In Tumble Dryer

### Key Features:

- > 7Kg Capacity
- > 8 Programmes
- > Vented
- > Sensor Dryer
- > Reverse Action
- > 135 Min. Cycle
- > Vent Kit Included



**Annual Energy Consumption:** 519kWh  
**Annual Water Consumption:** N/A  
**Dimensions:** H865-890 W595 D530mm

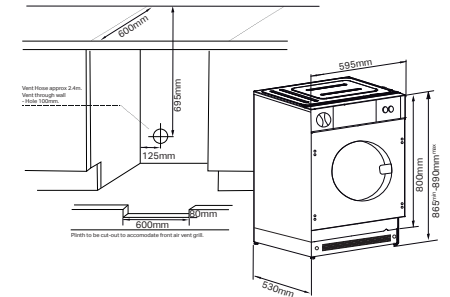

# Built-In Laundry |

Model Number	MWBI6012	MWBI7021	MWBI8014	MWDI7555	MTDI7S
Type	Washing Machine	Washing Machine	Washing Machine	Washer Dryer	Tumble Dryer
Max. Spin Speed (RPM)	1200	1200	1400	1400	-
Drum Capacity (kg)	6	7	8	7.5	7
Dry Capacity (kg)	-	-	-	5	7
Energy Efficiency Class	A+	A+++	A+++	A	C
Wash Performance Class	A	A+++	A+++	A	-
Spin Performance Class	B	B	A	A	-
Annual Energy Consumption (kWh)	176	173	196	208	519
Annual Water Consumption (Ltr)	9272	9899	9850	9800	-
Display Type	LED Progress Lights	LED	LED	LED	Mechanical
Variable Temperature	Yes	Yes	Yes	Yes	-
Variable Spin	600 / 1000	Yes	Yes	Yes	-
Number of Wash Programmes	18	15	15	13	-
Commonly Used Programmes	Cotton	Cotton Eco 40/60°C	Cotton	Cotton	-
Time for Wash (Common Programme)	-	170/195 mins.	-	-	-
Quick Wash	Yes - 30 mins.	Yes - 28 mins.-7kg	Yes - 30 mins.	Rapid-14,30,44 min.	-
Time Delay	-	Yes - 19hr	Yes - 24hr	Yes - 24hr	-
Noise dB Wash	52	56	61	56	-
Noise dB Spin	74	73	79	77	-
Dryer Noise Level dB	-	-	-	58	62
Cold Fill	Yes	Yes	Yes	Yes	-
Drying Timer	-	-	-	-	135 min.
Number of Drying Programmes	-	-	-	3	8
Heat Settings	-	-	-	2- High / Low	2- High / Low
Sensor Dryer	-	-	-	-	Yes
Dimensions (mm)	H820 W595 D580	H820 W597 D554	H820 W596 D570	H820 W596 D570	H865-890 W595 D530
Net Weight (kg)	68	71	-	71	32
EAN Number	8003437218651	5023790037457	-	8016361933705	5025761002822

# Built-In Dishwashing I



## MDI450-2 Integrated Slimline Dishwasher

### Key Features:

- > 10 Place Settings
- > 4 Temperatures
- > 6 Programmes
- > Time Delay
- > LED Progress Lights
- > Adjustable Racking



**Annual Energy Consumption:** 211kWh  
**Annual Water Consumption:** 3080Ltr  
**Dimensions:** H820-870 W450 D596mm

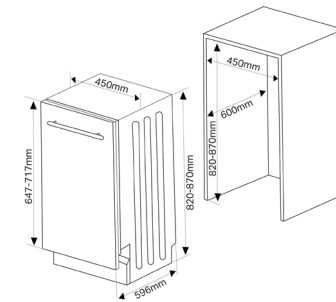

## MDI500 Integrated Slimline Dishwasher

### Key Features:

- > 10 Place Settings
- > 6 Temperatures
- > 8 Programmes
- > Cutlery Tray
- > 30 Min. Quick Wash
- > LED Progress Lights
- > Adjustable Racking



**Annual Energy Consumption:** 211kWh  
**Annual Water Consumption:** 2520Ltr  
**Dimensions:** H820-870 W450 D550mm

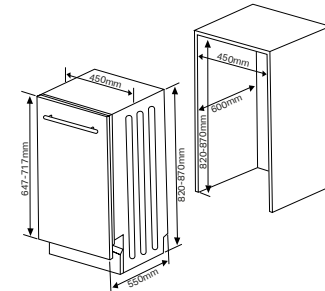

## MDI650X | MDI650W | MDI650K Semi-Integrated Full Size Dishwasher

### Key Features:

- > 12 Place Settings
- > 5 Temperatures
- > 9 Programmes
- > Time Delay
- > LED Display
- > 1/2 Load Button
- > Adjustable Racking
- > Stainless Steel, White or Black Control Panel



**Annual Energy Consumption:** 258kWh  
**Annual Water Consumption:** 2520Ltr  
**Dimensions:** H820-870 W596 D573mm

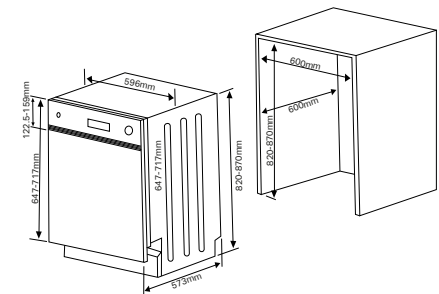

# Built-In Dishwashing I



## MDI600 Integrated Full Size Dishwasher

### Key Features:

- > 12 Place Settings
- > 4 Temperatures
- > 5 Programmes
- > Start Delay
- > LED Progress Lights
- > Adjustable Racking



**Annual Energy Consumption:** 285kWh  
**Annual Water Consumption:** 3360Ltr  
**Dimensions:** H820-870 W596 D573mm

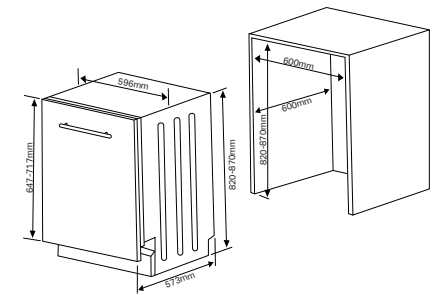

## MDI700 Integrated Full Size Dishwasher

### Key Features:

- > 12 Place Settings
- > 5 Temperatures
- > 9 Programmes
- > Time Delay
- > Interior Light
- > Adjustable Racking



**Annual Energy Consumption:** 258kWh  
**Annual Water Consumption:** 2520Ltr  
**Dimensions:** H820-870 W596 D573mm

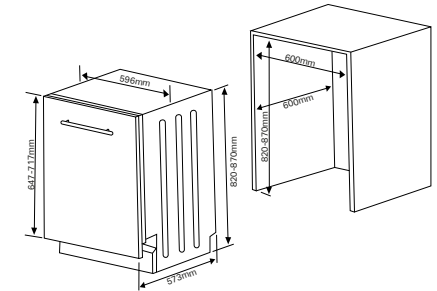

## MDI800 Integrated Full Size Dishwasher

### Key Features:

- > 15 Place Settings
- > 6 Temperatures
- > 9 Programmes
- > Time Delay
- > Cutlery Tray
- > Info LED
- > 1/2 Load Button
- > Touch Controls
- > Folding Basket & Plate Prongs



**Annual Energy Consumption:** 267kWh  
**Annual Water Consumption:** 2520Ltr  
**Dimensions:** H820-870 W596 D573mm

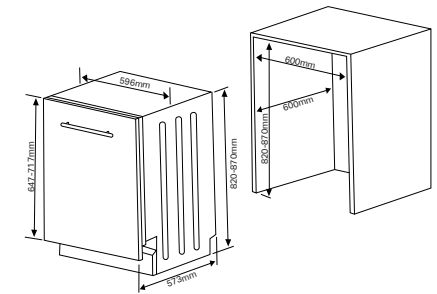



# Built-In Dishwashing |

Model Number	MDI450-2	MDI500	MDI650W/K/X	MDI600	MDI700	MDI800
<b>Width (cm)</b>	45	45	60	60	60	60
<b>Integrated (Fully, Semi, Slimline)</b>	Slimline Full Int.	Slimline Full Int.	Semi Int.	Fully Int.	Fully Int.	Fully Int.
<b>Place Settings</b>	10	10	12	12	12	15
<b>Energy Efficiency Class</b>	A++	A++	A++	A+	A++	A++
<b>Drying Performance Class</b>	A	A	A	A	A	A
<b>Annual Energy Consumption (kWh)</b>	211	211	258	285	258	267
<b>Annual Water Consumption (Ltr)</b>	3080	2520	2520	3360	2520	2520
<b>Noise Level (dB)</b>	52	49	49	54	52	47
<b>Number of Programmes</b>	6	8	9	5	9	9
<b>Number of Temperatures</b>	4	6	5	4	5	6
<b>Standard Programme</b>	Eco	Eco	Eco 50°C	Eco 50°C	Eco 50°C	Eco 50°C
<b>Time for Standard Programme (min.)</b>	198	191	166	160	162	171
<b>Half Load</b>	Yes-Half Load Button	Yes-Half Load Button	Yes-Half Load Button	Yes	Yes-Half Load Button	Yes-Half Load Button
<b>Delay Timer</b>	Yes - 3,6,9hr	Yes - 19hr	Yes	Yes - 3,6,9hr	Yes - 19hr	Yes - 19hr
<b>Adjustable Racking (Upper Basket)</b>	Yes	Yes	Yes	Yes	Yes	Yes
<b>Fold-able Spines (Bottom Basket)</b>	-	Yes	-	-	-	Yes
<b>Cutlery Tray</b>	-	Yes	-	-	-	Yes
<b>Info LED</b>	-	-	-	-	-	Yes
<b>Interior Light</b>	-	-	-	-	Yes	-
<b>Salt &amp; Rinse Aid Indicator</b>	Yes	Yes	Yes	Yes	Yes	Yes
<b>Overflow Protection</b>	Yes	Yes	Yes	Yes	Yes	Yes
<b>Net Weight (kg)</b>	32	32	41	38	38	38
<b>Gross Weight (Inc. Packaging) (kg)</b>	34	34	43	40	40	40
<b>Dimensions Product (mm)</b>	H820-870 W450 D596	H820-870 W450 D550	H820-870 W596 D573	H820-870 W596 D573	H820-870 W596 D573	H820-870 W596 D573
<b>Dimensions Packed (mm)</b>	H861 W494 D661	H861 W494 D661	H861 W644 D661	H861 W644 D661	H861 W644 D661	H861 W644 D661
<b>EAN</b>	5055862314029	5055862312063	5055862304068-X 5055862312049-W 5055862312068-K	5055862303573	5055862304051	5055862308578

# Built-In Cooking | Ovens



## SG061X Integrated 73Ltr Gas Oven

### Key Features:

- > 3 Functions
- > Rotary Controls
- > Minute Minder
- > 2 Wire Racks
- > Easy Clean Enamel Lining
- > Black & Inox

(Currently only available to order through telesales)



**Total Power:** -  
**Net Weight:** -  
**Dimensions:** H594 W594 D560mm

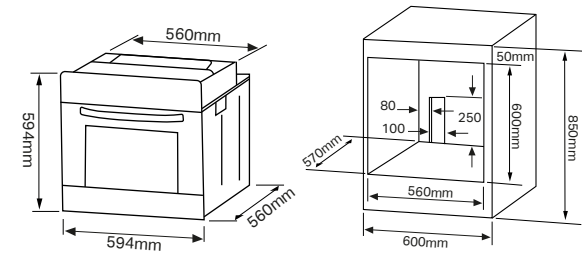

## SFO58X Integrated 65Ltr Single Oven

### Key Features:

- > Digital Timer
- > Delay Timer
- > 8 Functions
- > Rotary Controls
- > Forced Cooling System
- > Ribbed Cavity
- > Black & Stainless Steel

(Currently only available to order through telesales)



**Total Power:** 3.0kWh  
**Net Weight:** -  
**Dimensions:** H595 W595 D575mm

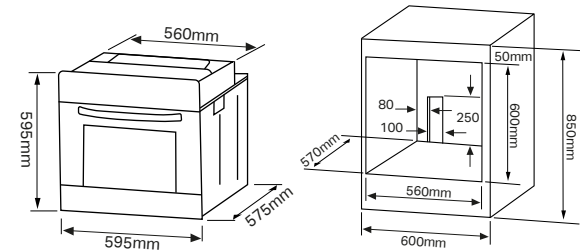

## SFO72X Integrated 70Ltr Single Oven

### Key Features:

- > LED Timer
- > 8 Functions
- > Rotary Controls
- > Forced Cooling System
- > Removable Door Plate
- > 1 x Baking Pan
- > 1 x Baking Rack
- > Stainless Steel

(Currently only available to order through telesales)



**Total Power:** 3.0kWh  
**Net Weight:** -  
**Dimensions:** H595 W595 D575mm

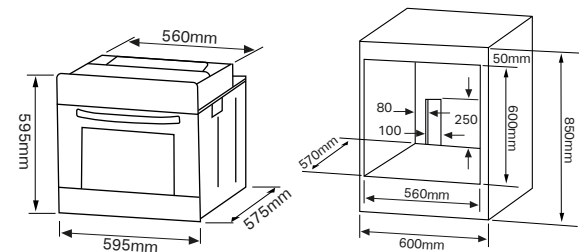

## SFO65MX | SFO65MW Integrated 65Ltr Single Oven

### Key Features:

- > Minute Minder
- > Multifunction
- > 8 Functions
- > Rotary Controls
- > 2 Wire Racks Inc.
- > Oven Light
- > Stainless Steel or White



**Total Power:** 2.6kWh  
**Net Weight:** -  
**Dimensions:** H595 W595 D575mm

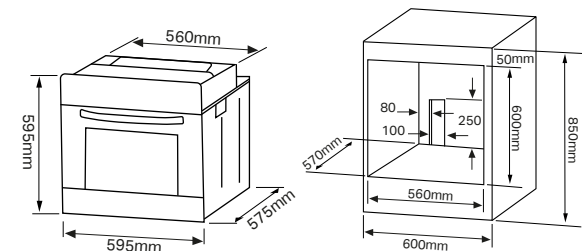

# Built-In Cooking | Ovens



## SFO67MBX Integrated 65Ltr Single Oven

### Key Features:

- > Programmable Timer
- > Multifunction
- > Illuminated Pop-In Pop-Out Controls
- > Catalytic Back
- > Soft Close Door
- > Black with S/Steel Trim



**Total Power:** 3.1kWh  
**Net Weight:** -  
**Dimensions:** H595 W595 D575mm

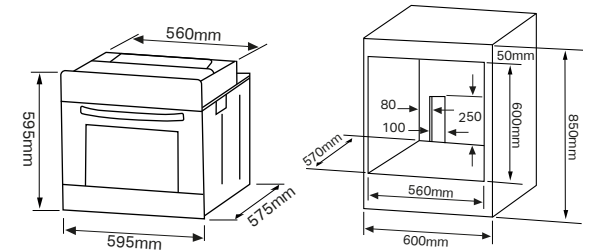

## SFO68MFB Integrated 65Ltr Single Oven

### Key Features:

- > Programmable Timer
- > Multifunction
- > Full Touch Control
- > Catalytic Back Liners
- > Oven Light
- > Half Telescopic Runners with Stabilisers
- > Black



**Total Power:** 3.1kWh  
**Net Weight:** -  
**Dimensions:** H595 W595 D575mm

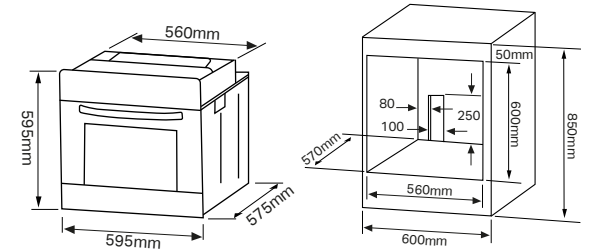

## SFOM69MX Integrated 65Ltr Single Oven

### Key Features:

- > Programmable Timer
- > Multifunction
- > Illuminated Pop-In Pop-Out Controls
- > Soft Close Door
- > Half Telescopic Runners with Stabilisers
- > Stainless Steel & Mirror



**Total Power:** 3.1kWh  
**Net Weight:** -  
**Dimensions:** H595 W595 D575mm

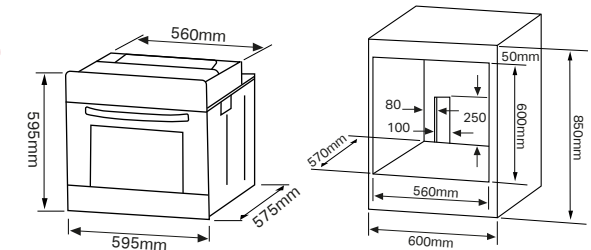

## SFO75MWG Integrated 75Ltr Single Oven

### Key Features:

- > Programmable Timer
- > Multifunction
- > Pop-In Pop-Out Controls
- > Catalytic Back
- > Soft Close Door
- > Half Telescopic Runners with Stabilisers
- > White Glass



**Total Power:** 3.1kWh  
**Net Weight:** -  
**Dimensions:** H595 W595 D575mm

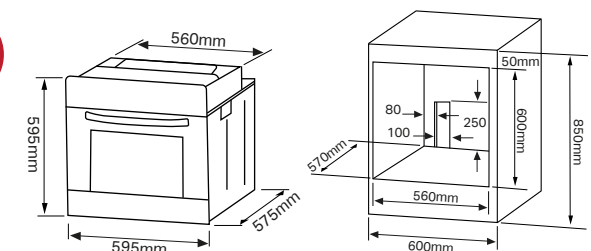

# Built-In Cooking | Ovens



## SFPO77MBX Integrated 75Ltr Pyrolytic Oven

### Key Features:

- > Programmable Timer
- > Multifunction
- > Pyrolytic
- > Full Touch Controls
- > Door Switch
- > Full Telescopic Runners with Stabilisers
- > Soft Close Door
- > Black with S/Steel Trim



**Total Power:** 2.6kWh  
**Net Weight:** -  
**Dimensions:** H595 W595 D575mm

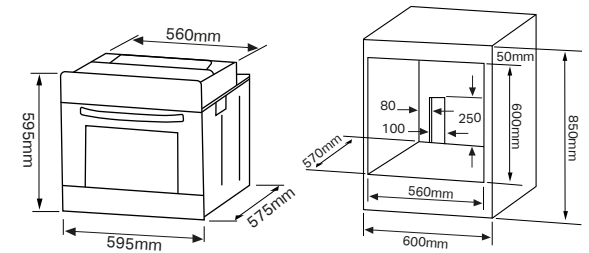

## SFOS78MBX Integrated 75Ltr Single Oven

### Key Features:

- > Programmable Timer
- > Multifunction
- > Steam Clean Prog.
- > Twist & Press Knobs
- > Full Colour Screen
- > Auto Cooking Progs.
- > Catalytic Back & Sides
- > Soft Close Door
- > Black with S/Steel Trim



**Total Power:** 3.1kWh  
**Net Weight:** -  
**Dimensions:** H595 W595 D575mm

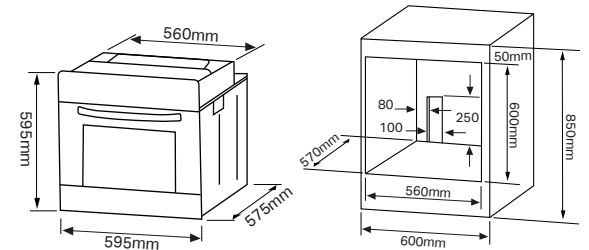

## SFOP94MFGG - Oven & Gas on Glass Hob Pack Integrated 65Ltr Single Oven

### Key Features:

- > Programmable Timer
- > Multifunction
- > Fan Oven
- > Pop-In Pop-Out Controls
- > 2 Wire Racks, 1 Drip Tray
- > Oven Light
- > Black



**Total Power:** 3.0kWh  
**Net Weight:** 38kg  
**Dimensions:** H595 W595 D575mm

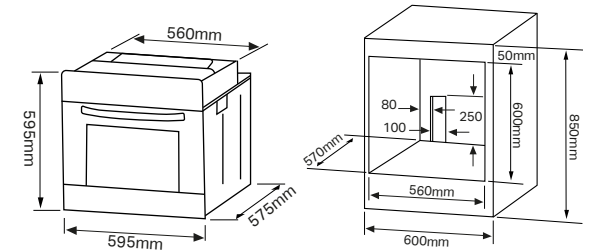

## SFOP60MC - Oven & Ceramic Hob Pack Integrated 58Ltr Single Oven

### Key Features:

- > Minute Minder
- > Fan Oven
- > 8 Functions
- > Rotary Controls
- > 2 Wire Racks, 1 Drip Tray
- > Oven Light
- > Stainless Steel



**Total Power:** 3.0kWh  
**Net Weight:** 38kg  
**Dimensions:** H595 W595 D575mm

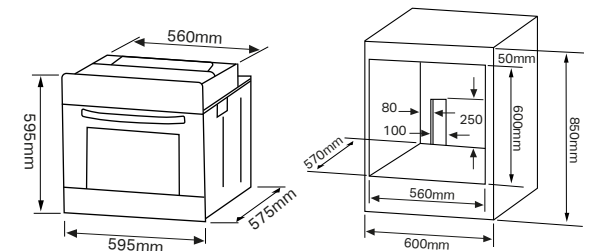

# Built-In Cooking | Ovens



## SFCP10 - Electric Oven & Ceramic Hob Pack Integrated 57Ltr Single Oven

### Key Features:

- > Mechanical Timer
- > Fan Assisted Oven
- > 5 Functions
- > Rotary Controls
- > Oven Thermostat
- > Double Glazed Glass Door
- > Black

(Currently only available to order through telesales)



**Total Power:** 2.6kWh  
**Net Weight:** -  
**Dimensions:** H590 W595 D543mm

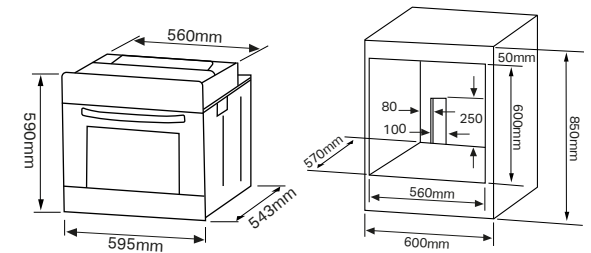

## MDO70X\* Built-Under Double Oven

### Key Features:

- > Multifunction
- > Programmable Timer
- > Rotary Controls
- > 2 Wire Shelves
- > Easy Clean Enamel Lining
- > Drop Down Oven Door
- > Stainless Steel



**Total Power:** 4kWh  
**Net Weight:** 42.6kg  
**Dimensions:** H715 W595 D555mm

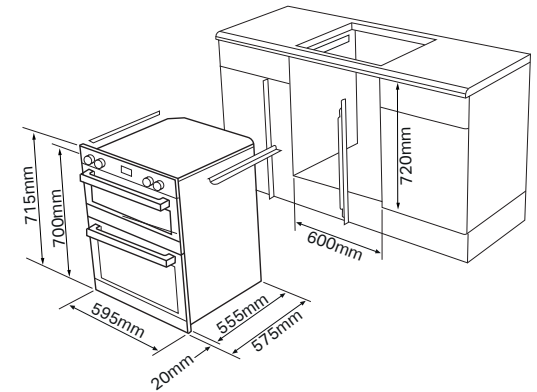

## MDO90X\* | MDO90K\* Built-In Double Oven

### Key Features:

- > Multifunction
- > Programmable Timer
- > Rotary Controls
- > 2 Wire Shelves
- > Easy Clean Enamel Lining
- > Drop Down Oven Door
- > Black



**Total Power:** 4.2kWh  
**Net Weight:** 45.8kg  
**Dimensions:** H890 W594 D567mm

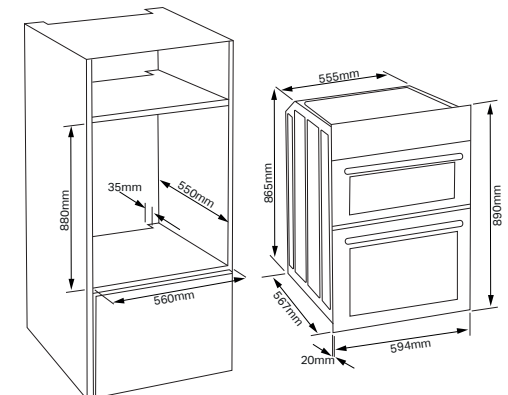

# Built-In Cooking | Ovens

Model Number	SGO61X	SFO58X	SFO72X	SFO65MX & SFO65MW	SFO67MBX
<b>Oven Type (size)</b>	Single	Single	Single	Single	Single
<b>Cavity Volume (ltr) (usable)</b>	57	65	70	65	65
<b>Control Panel Type</b>	Black Glass	Stainless Steel	Stainless Steel	Metal	Black Glass
<b>Knob Type</b>	Rotary	Rotary	Rotary	Rotary	Pop-In Pop-Out
<b>Timer/Programmer</b>	Minute Minder	Yes - Timer	Yes - Programmable	Minute Minder	Yes - Programmable
<b>Removable Door</b>	Standard	Standard	Standard	Standard	Easy Removable
<b>Removable Inner Door Glass</b>	Yes - Screw	Yes - Screw	Yes - Screw	Yes - Screw	Yes - Clip
<b>Number of Functions</b>	3	8	9	8	9
<b>Function Types</b>	Gas Oven Grill Base Element Burner	Oven Light Defrost Bottom Heater Conventional Cooking Convection With Fan Grill - Small Double Grill Double Grill With Fan and Convection	Oven Light Defrost Bottom Heater Conventional Cooking Convection With Fan Radiant Grill Double Grill Double Grill With Fan Convection	Oven Light Defrost Bottom Top+Bottom Top + Bottom + Fan Grill Double Grill Double Grill + Fan	Oven Light Defrost TruFan™ Top + Bottom Top + Bottom + Fan Pizza Grill Double Grill Double Grill with Fan
<b>Oven Configuration</b>	-	Multifunction	Multifunction	Multifunction	Multifunction
<b>Hob Type (Oven &amp; Hob Pack Only)</b>	-	-	-	-	-
<b>Cavity Type &amp; Colour</b>	Black Enamel	Black Enamel	Black Enamel	Black Enamel	Black Enamel
<b>Oven Cleaning</b>	Easy Clean Enamel	Easy Clean Enamel	Easy Clean Enamel	Easy Clean Enamel	Catalytic Back
<b>Number of Chrome Wire Shelves Inc.</b>	2	2	2	2	2
<b>Telescopic Shelves</b>	-	-	-	-	Yes
<b>Stabilisers</b>	-	-	-	-	Yes
<b>Full Width Deep Tray with Grid</b>	Yes	Yes	Yes	Yes	Yes
<b>Energy Efficiency Class</b>	A	A	A	A	A
<b>kWh/Cycle-Convectional/Forced Fan</b>	2.15	0.99/0.87	0.99/0.87	-	-
<b>Soft Close Door</b>	-	-	-	-	Yes
<b>Total Power (kW) Max</b>		3.0	3.0	2.6	3.1
<b>Hard Wired / Cable</b>	Hardwired-Terminal box	13-20Amp	13-20Amp	13 amp	13/20 amp
<b>Net/Gross Weight (kg)</b>	-	-	-	29.3	-
<b>Dimensions (Product) (mm)</b>	H594 W594 D560	H595 W595 D575	H595 W595 D575	H595 W595 D575	H595 W595 D575
<b>Dimensions (Packed) (mm)</b>	H660 W640 D660	H670 W648 D690	H670 W648 D690	H670 W648 D688	H670 W648 D688
<b>EAN Number</b>	-	5060617980022	5060617980039	MX - 5055862312308 MW-5055862320532	5055862320549

# Built-In Cooking | Ovens

Model Number	SFO68MFB	SFOM69MX	SFO75MWG	SFPO77MBX	SFOS78MBX
Oven Type (size)	Single	Single	Single	Single	Single
Cavity Volume (ltr) (usable)	65	65	75	75	75
Control Panel Type	Black Glass	Metal	White Glass	Black Glass	Black Glass
Knob Type	Full Touch	Pop-In Pop-Out	Pop-In Pop-Out	Full Touch	Twist & Press
Timer/Programmer	Yes - Programmable	Yes - Programmable	Yes - Programmable	Yes - Programmable	Yes - Programmable
Removable Door	Easy Removable	Easy Removable	Easy Removable	Easy Removable	Easy Removable
Removable Inner Door Glass	Yes - Clip	Yes - Clip	Yes - Clip	Yes - Clip	Yes - Clip
Number of Functions	7	9	7	9	10
Function Types	Oven Light Defrost TruFan™ Top + Bottom Top + Bottom + Fan Grill Double Grill	Oven Light Defrost TruFan™ Top + Bottom Top + Bottom + Fan Pizza Grill Double Grill Double Grill with Fan	Oven Light Defrost TruFan™ Top + Bottom Top + Bottom + Fan Grill Double Grill	Oven Light Defrost Top & Bottom Heat TruFan™ Top + Bottom + Fan Grill Double Grill, Double Grill with Fan, Pyrolytic Mode	Oven Light Defrost TruFan™ Top+Bottom Top + Bottom + Fan Pizza Grill + Turnspit Double Grill + Turnspit, Double Grill+Fan+Turnspit, Steam Clean
Oven Configuration	Multifunction	Multifunction	Multifunction	Multifunction	Multifunction
Hob Type (Oven & Hob Pack Only)	-	-	-	-	-
Cavity Type & Colour	Black Enamel	Black Enamel	Black Enamel	Black Enamel	Catalytic Back & Sides
Oven Cleaning	Catalytic Back	Catalytic Back	Catalytic Back	Pyrolytic	Catalytic Back & Sides
Number of Chrome Wire Shelves Inc.	2	2	2	2	2
Telescopic Shelves	Yes	Yes	Yes	Yes	Yes
Stabilisers	Yes	Yes	Yes	Yes	Yes
Full Width Deep Tray with Grid	Yes	Yes	Yes	Yes	Yes
Energy Efficiency Class	A	A	A	A	A+
kWh/Cycle-Convectional/Forced Fan	0.98/0.87	0.98/0.87	0.86/0.71	0.99/0.93	0.86/0.71
Soft Close Door	Yes	Yes	Yes	Yes	Yes
Total Power (kW) Max	3.1	3.1	3.1	2.6	3.1
Hard Wired / Cable	13/20 amp	13/20 amp	13/20 amp	13 amp	13/20 amp
Net/Gross Weight (kg)	-	-	-	-	-
Dimensions (Product) (mm)	H595 W595 D575	H595 W595 D575	H595 W595 D575	H595 W595 D575	H595 W595 D575
Dimensions (Packed) (mm)	H670 W648 D688	H670 W648 D688	H670 W648 D688	H670 W648 D688	H670 W648 D688
EAN Number	5055862320594	5055862320570	5055862320587	5055862320556	5055862320563

# Built-In Cooking | Ovens

Model Number	SFOP94MFGG	SFOP60MC	SFCP10	MDO70X	MDO90K/X
<b>Oven Type (size)</b>	Single	Single	Single	Double	Double
<b>Cavity Volume (ltr) (usable)</b>	65	58	57	36/48	36/69
<b>Control Panel Type</b>	Glass	Metal	Black Glass	Metal	Metal
<b>Knob Type</b>	Pop-In Pop-Out	Rotary	Rotary	Rotary	Rotary
<b>Timer/Programmer</b>	Yes - Programmable	Minute Minder	Yes	Yes - Programmable	Yes - Programmable
<b>Removable Door</b>	Yes	Yes	Yes	-	-
<b>Removable Inner Door Glass</b>	Yes - Screw	Yes - Screw	Yes - Screw	Yes - Screw	Yes - Screw
<b>Number of Functions</b>	9	8	5	8	8
<b>Function Types</b>	Oven Light Defrost Bottom Top+Bottom Top + Bottom + Fan Grill Double Grill Double Grill + Fan Convection	Oven Light Defrost Bottom Top+Bottom Top + Bottom + Fan Grill Double Grill Double Grill + Fan	Oven Light Grill Grill & Fan Fan Assisted Defrost	Oven Light Defrost Top & Bottom Heating Bottom Heat Operating With Fan Fan Heating Grill Full Grill	Oven Light Defrost Top & Bottom Heating Bottom Heat Operating With Fan Fan Heating Grill Full Grill
<b>Oven Configuration</b>	Oven & Hob Pack	Oven & Hob Pack	Oven & Hob Pack	Multifunction	Multifunction
<b>Hob Type (Oven &amp; Hob Pack Only)</b>	Gas on Glass	Ceramic Side Touch	Ceramic Front Touch	-	-
<b>Cavity Type &amp; Colour</b>	Black Enamel	Black Enamel	Black Enamel	Black Enamel	Black Enamel
<b>Oven Cleaning</b>	Easy Clean Enamel	Easy Clean Enamel	Easy Clean Enamel	Easy Clean Enamel	Easy Clean Enamel
<b>Number of Chrome Wire Shelves Inc.</b>	2	2	1	2	2
<b>Telescopic Shelves</b>	-	-	-	-	-
<b>Stabilisers</b>	-	-	-	-	-
<b>Full Width Deep Tray with Grid</b>	Yes	Yes	1 x Normal Tray	Yes	Yes
<b>Energy Efficiency Class</b>	A	A	A	A	A
<b>kWh/Cycle-Convectional/Forced Fan</b>	0.99/0.87	0.99/0.87	0.8/Forced	0.74/0.79	0.74/0.79
<b>Soft Close Door</b>	-	-	-	-	-
<b>Total Power (kW) Max</b>	3.0	3.0	2.6	4	4.2
<b>Hard Wired / Cable</b>	13amp	13amp	13amp	Yes	Yes
<b>Net/Gross Weight (kg)</b>	38.8/49	38/43.4	-	42.6/45.6	45.8/49
<b>Dimensions (Product) (mm)</b>	H595 W595 D575	H595 W595 D575	H590 W595 D543	H715 W595 D555	H890 W594 D567
<b>Dimensions (Packed) (mm)</b>	H785 W648 D688	H785 W648 D688	-	-	-
<b>EAN Number</b>	5060217413685	5060217413111	5060617980282	50237900037990	50237900337983



# Built-In Cooking | Hobs



## SP300X 30cm Solid Plate Domino Hob

### Key Features:

- > 2 Solid Plates
- > Heat Indicator Light
- > Front Rotary Controls
- > Stainless Steel



**Power:** 2500W  
**Connection Type:** 13/20amp  
**Dimensions:** H40 W290 D510mm

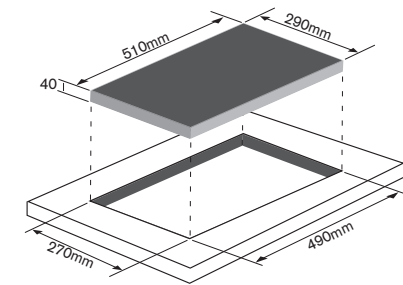

## SP600X | SP600W 60cm Solid Plate Hob

### Key Features:

- > 4 Solid Plates
- > Heat Indicator Light
- > Side Rotary Controls
- > Stainless Steel or White



**Power:** 5500W  
**Connection Type:** 32amp  
**Dimensions:** H55 W590 D510mm

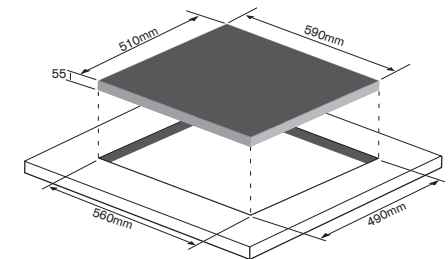

## CER31NT 30cm Ceramic Domino Hob

### Key Features:

- > 2 Zones
- > No Timer
- > Front Touch Controls
- > Child Lock
- > Heat Indicator Light
- > Black



**Power:** 3000W  
**Connection Type:** 16amp  
**Dimensions:** H53 W300 D520mm

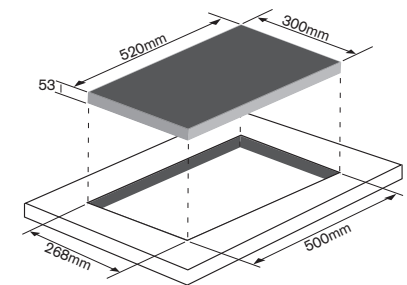

## CER31T15 30cm Ceramic Domino Hob

### Key Features:

- > 2 Zones
- > Heat Indicator Light
- > Front Touch Controls
- > Child Lock
- > 15 min. Timer
- > Black



**Power:** 3000W  
**Connection Type:** 16amp  
**Dimensions:** H53 W300 D520mm

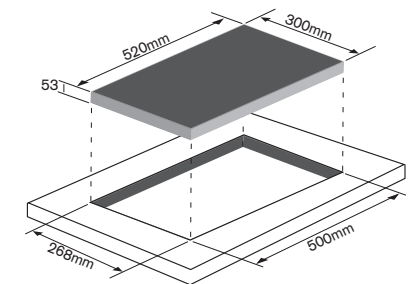

# Built-In Cooking | Hobs



**CT250**  
30cm Ceramic Domino Hob

**Key Features:**

- > 2 Zones
- > Front Touch Controls
- > Child Lock
- > Heat Indicator Light
- > 99 Min Timer
- > Black



**Power:** 2900W  
**Connection Type:** 16amp  
**Dimensions:** H37 W290 D520mm

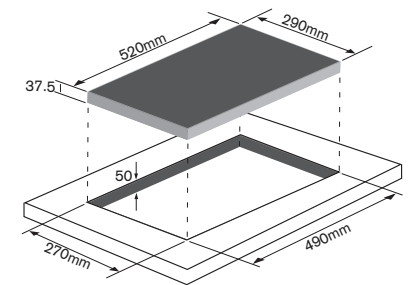

**CER61NT**  
60cm Ceramic Hob

**Key Features:**

- > 4 Zones
- > Front Touch Controls
- > No Timer
- > Child Lock
- > Heat Indicator Light
- > Black



**Power:** 6000W  
**Connection Type:** 32amp  
**Dimensions:** H68 W580 D510mm

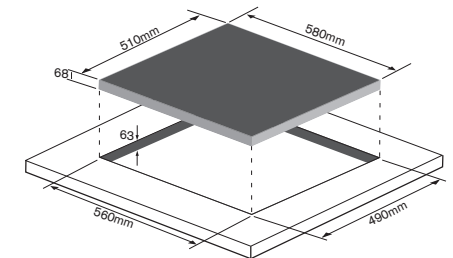

**CER61T15**  
60cm Ceramic Hob

**Key Features:**

- > 4 Zones
- > Front Touch Controls
- > 15 min. Timer
- > Child Lock
- > Heat Indicator Light
- > Black



**Power:** 6000W  
**Connection Type:** 32amp  
**Dimensions:** H68 W580 D510mm

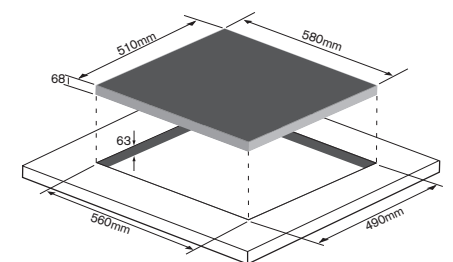

**CKH61**  
60cm Ceramic Hob

**Key Features:**

- > 4 Zones
- > Side Rotary Controls
- > Heat Indicator Light
- > Black



**Power:** 6000W  
**Connection Type:** 32amp  
**Dimensions:** H65 W580 D510mm

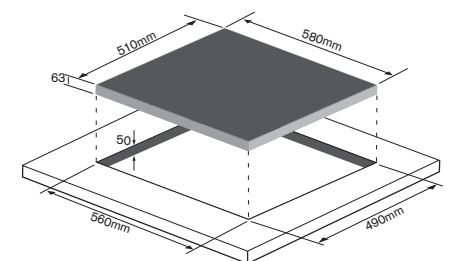

# Built-In Cooking | Hobs

## CT785 77cm Ceramic Hob



### Key Features:

- > 5 Zones
- > Central Dual Zone
- > Front Touch Controls
- > 99 min. Timer
- > Heat Indicator Light
- > Child Lock
- > Heat Booster Button
- > Black



**Power:** 8200W  
**Connection Type:** 40amp  
**Dimensions:** H52 W770 D520mm

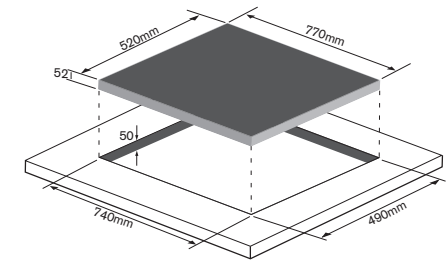

## INT31T15 30cm Induction Domino Hob



### Key Features:

- > 2 Zones
- > Front Touch Controls
- > 15 Min. Timer
- > Child Lock
- > Heat Indicator Light
- > Black



**Power:** 3500W  
**Connection Type:** 20amp  
**Dimensions:** H53 W288 D520mm

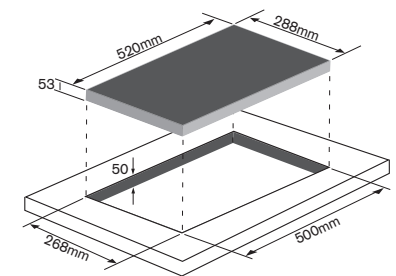

## INT300 30cm Induction Domino Hob

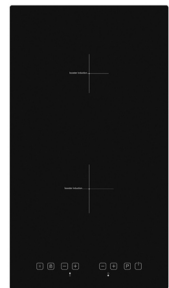

### Key Features:

- > 2 Zones
- > Front Touch Controls
- > No Timer
- > Child Lock
- > Heat Indicator Light
- > Black



**Power:** 3500W  
**Connection Type:** 20amp  
**Dimensions:** H56 W290 D520mm

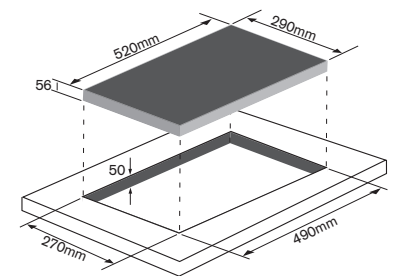

SP600W - Rotary Controls



SP600X - Rapid Plate



INT785 Touch Controls



Induction Boost On Selected Models

# Built-In Cooking | Hobs



## INT61T99-13A 60cm Induction Hob

### Key Features:

- > 4 Zones
- > Front Touch Controls
- > 99 min. Timer
- > Child Lock
- > Heat Indicator Light
- > 9 Power Levels
- > 13A Connection
- > Black



**Power:** 3000W (max limit)

**Connection Type:** 13 amp Plug Attached

**Dimensions:** H77 W590 D520mm

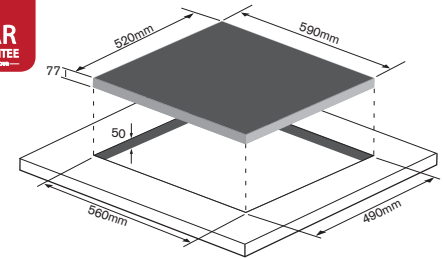

## INT61NT 60cm Induction Hob

### Key Features:

- > 4 Zones
- > Front Touch Controls
- > No Timer
- > Child Lock
- > Heat Indicator Light
- > 9 Power Levels
- > Black



**Power:** 7000W

**Connection Type:** 32amp

**Dimensions:** H77 W590 D520mm

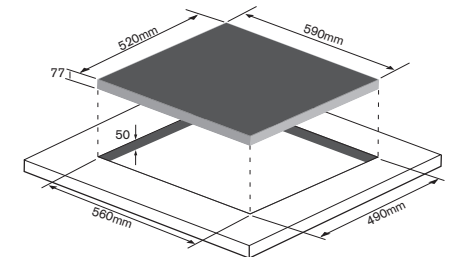

## INT61T15 60cm Induction Hob

### Key Features:

- > 4 Zones
- > Front Touch Controls
- > 15 min. Timer
- > Child Lock
- > Heat Indicator Light
- > 9 Power Levels
- > Black



**Power:** 7000W

**Connection Type:** 32amp

**Dimensions:** H77 W590 D520mm

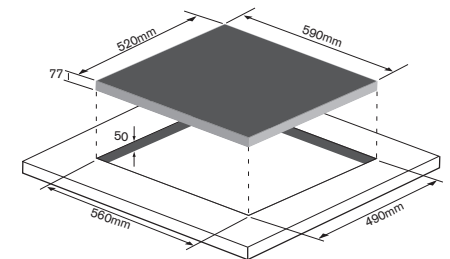

## INT460F 60cm Induction Hob

### Key Features:

- > 4 Zones
- > ConnectCook
- > 99 Min. Timer
- > Child Lock
- > Hob Hot Indicator
- > Heat Booster Button
- > Black



**Power:** 6600-7200W

**Connection Type:** 32amp

**Dimensions:** H53 W590 D520mm

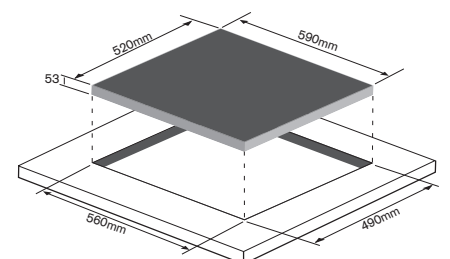

# Built-In Cooking | Hobs



## INT785 77cm Induction Hob

### Key Features:

- > 5 Zones
- > Central Dual Zone
- > Front Touch Controls
- > Timer
- > Heat Indicator Light
- > Child Lock
- > Heat Booster Button
- > Stand By Mode
- > Black



**Power:** 6800-7400W  
**Connection Type:** 32amp  
**Dimensions:** H62 W770 D520mm

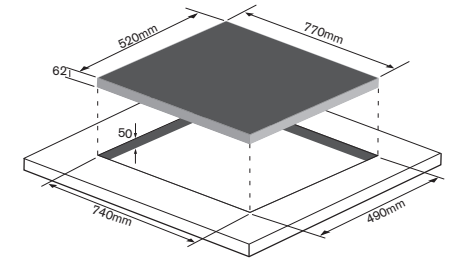

## INT901 90cm Induction Hob

### Key Features:

- > 5 Zones
- > Front Touch Controls
- > Timer & Smart Pause
- > Heat Indicator Light
- > Panel Key Lock
- > Heat Booster Button
- > Black



**Power:** 6800-7400W  
**Connection Type:** 32amp  
**Dimensions:** H62 W900 D520mm

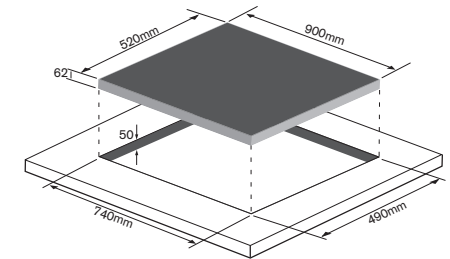

## GH30X 30cm Gas Domino Hob

### Key Features:

- > 2 Gas Burners
- > Front Rotary Controls
- > Cast Iron Pan Supports
- > Auto Ignite
- > Flame Failure Protection
- > Stainless Steel



**Power:** 4.0kW  
**LPG Convertible:** Yes - Jets Included  
**Dimensions:** H90 W300 D520mm

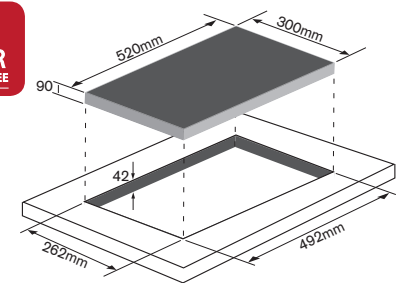

## GH30BG 30cm Gas Domino Hob

### Key Features:

- > 2 Gas Burners
- > Front Rotary Controls
- > Enamel Pan Supports
- > Auto Ignite
- > Flame Failure Protection
- > Black Glass



**Power:** 4.0kW  
**LPG Convertible:** Yes - Jets Included  
**Dimensions:** H90 W300 D520mm

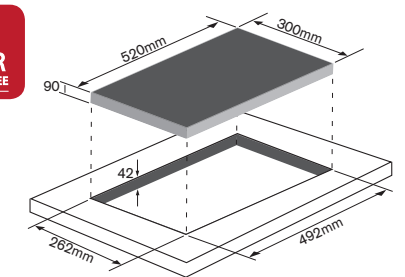

# Built-In Cooking | Hobs



## **GH60X** 60cm Gas Hob

### Key Features:

- > 4 Gas Burners
- > Side Rotary Controls
- > Enamel Pan Supports
- > Auto Ignite
- > Stainless Steel



**Power:** 7.5kW

**LPG Convertible:** Yes - Jets Included

**Dimensions:** H95 W590 D500mm

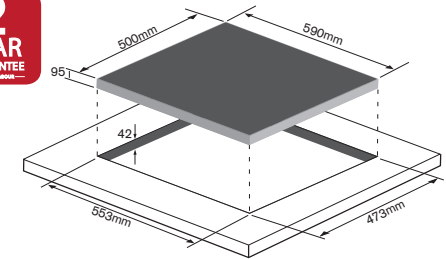

## **GH60BG** 60cm Gas Hob

### Key Features:

- > 4 Gas Burners
- > Front Rotary Controls
- > Cast Iron Pan Supports
- > Auto Ignite
- > Flame Failure Device
- > Gas On Black Glass



**Power:** 7.5kW

**LPG Convertible:** Yes - Jets Included

**Dimensions:** H110 W600 D510mm

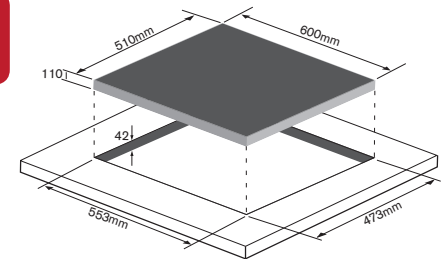

## **GH61X** 60cm Gas Hob

### Key Features:

- > 4 Gas Burners
- > Front Rotary Controls
- > Cast Iron Pan Supports
- > Auto Ignite
- > Flame Failure Device
- > Stainless Steel



**Power:** 7.5kW

**LPG Convertible:** Yes - Jets Included

**Dimensions:** H95 W590 D500mm

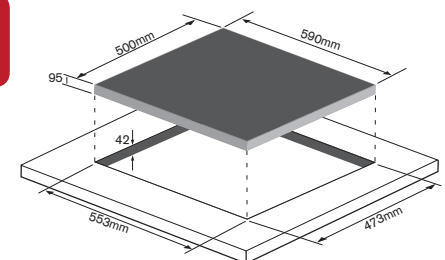

## **GH75BG** 60cm Gas Hob

### Key Features:

- > 5 Gas Burners Inc. Wok
- > Front Rotary Controls
- > Cast Iron Pan Supports
- > Auto Ignite
- > Gas Cut Off
- > Gas On Black Glass



**Power:** 10.8kW

**LPG Convertible:** Yes - Jets Included

**Dimensions:** H95 W750 D520mm

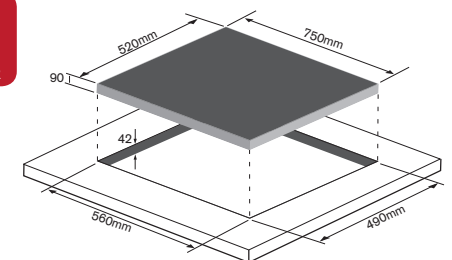

# Built-In Cooking | Hobs



## **GH71X** 70cm Gas Hob

### Key Features:

- > 5 Gas Burners Inc. Wok
- > Front Rotary Controls
- > Cast Iron Pan Supports
- > Auto Ignite
- > Stainless Steel



**Power:** 10.8kW

**LPG Convertible:** Yes - Jets Included

**Dimensions:** H95 W750 D510mm

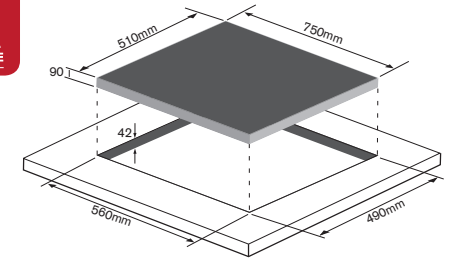

## **GH90BG** 90cm Gas Hob

### Key Features:

- > 5 Gas Burners Inc. Wok
- > Front Rotary Controls
- > Cast Iron Pan Supports
- > Auto Ignite
- > Gas Cut Off
- > Gas On Black Glass



**Power:** 10.8kW

**LPG Convertible:** Yes - Jets Included

**Dimensions:** H100 W860 D510mm

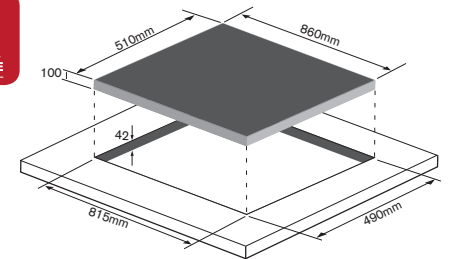

## **GH91X** 90cm Gas Hob

### Key Features:

- > 5 Gas Burners Inc. Wok
- > Front Rotary Controls
- > Cast Iron Pan Supports
- > Auto Ignite
- > Gas Cut Off
- > Stainless Steel



**Power:** 10.8kW

**LPG Convertible:** Yes - Jets Included

**Dimensions:** H90 W860 D510mm

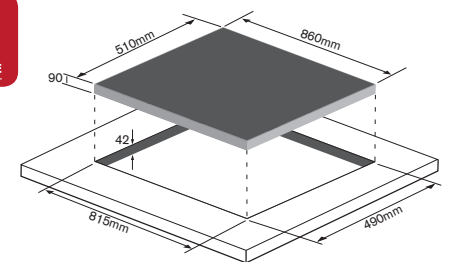

# Built-In Cooking | Hobs

Model Number	SP300X	SP600X SP600W	CER31NT	CER31T15	CT250	CER61NT	CER61T15
Hob Type	Solid Plate	Solid Plate	Ceramic - Domino	Ceramic - Domino	Ceramic - Domino	Ceramic	Ceramic
Width (cm)	30	60	30	30	30	60	60
Total Power (W)	2500	5500	3000	3000	2900	6000	6000
Control Mode	Rotary	Rotary	Touch	Touch	Touch	Touch	Touch
Power Levels	-	-	-	-	-	-	-
Number of Zones/Burners	2	4	2	2	2	4	4
Front Left Zone Power (W) (Front Domino)	1000	1500	1800	1800	1200	1800	1800
Back Left Zone Power (W) (Back Domino)	1500	1200	1200	1200	1900	1200	1200
Front Right Zone Power (W)	-	-	-	-	-	1200	1200
Back Right Zone Power (W)	-	-	-	-	-	1800	1800
Central Zone Power (W)	-	-	-	-	-	-	-
ConnectCook	-	-	-	-	-	-	-
Dual Zone	-	-	-	-	-	-	-
Pan Support Type	-	-	-	-	-	-	-
Gas on Glass	-	-	-	-	-	-	-
Booster Function / Rapid Zones (hot spot)	Rapid - Both Zones	Rapid - Front Zone	-	-	-	-	-
Timer	-	-	No Timer	15 min. Cut Out	99 min.	No Timer	15 min. Cut Out
Child Lock	-	-	-	-	Yes	-	-
Auto Safety Off (Auto Switch Off Safety-Gas)	-	-	-	-	Yes	-	-
Automatic Ignition	-	-	-	-	-	-	-
LPG Convertible	-	-	-	-	-	-	-
Residual Heat Indicator	-	-	Yes	Yes	Yes	Yes	Yes
Lead Supplied	Yes	Yes	Yes	Yes	Yes	Yes	Yes
Connection Type / amp	16/20 amp	32 amp	16 amp	16 amp	16 amp	32 amp	32 amp
Dimensions Product (mm)	H40 W290 D510	H55 W590 D510	H53 W300 D520	H53 W300 D520	H37.5 W290 D520	H68 W580 D510	H68 W580 D510
Dimensions Packed (mm)	H135 W345 D510	H135 W650 D570	H135 W560 D348	H135 W560 D348	-	H135 W650 D560	H135 W650 D560
Cut Out Dimensions (mm)	W270 D490	W560 D490	W268 D500	W268 D500	W270 D490	W560 D490	W560 D490
Air Gap Needed (mm)	50	50	50	50	50	50	50
Net Weight (kg)	5.2	9.4	4.5	4.5	4.6	-	-
EAN Number	5023790038003	X- 5060217414439 W-5055862399972	5055862303580	5060217414286	5.2	5060217414217	5060217413753



# Built-In Cooking | Hobs

Model Number	CKH61	CT785	INT31T15	INT300	INT61T99-13A	INT61NT
Hob Type	Ceramic	Ceramic	Induction	Induction	Induction	Induction
Width (cm)	60	77	30	30	60	60
Total Power (W)	6000	8200	3500	3500	3000	7000
Control Mode	Rotary	Touch	Touch	Touch	Touch	Touch
Power Levels	9	-	9	-	9	9
Number of Zones/Burners	4	5	2	2	4	4
Front Left Zone Power (W)	1800	1800	1500	1400 - 1800 (boost)	1500	2000
Back Left Zone Power (W)	1200	1200	2000	2100 - 2500 (boost)	1000	1500
Front Right Zone Power (W)	1800	1800	-	-	1000	1500
Back Right Zone Power (W)	1200	1200	-	-	1500	2000
Central Zone Power (kW)	-	2.2/1.0kW Dual Zone	-	-	-	-
ConnectCook	-	-	-	-	-	-
Dual Zone	-	Yes	-	-	-	-
Pan Support Type	-	-	-	-	-	-
Gas on Glass	-	-	-	-	-	-
Booster/Rapid Function	-	Booster	-	Booster	-	-
Timer	-	99 Min.	15 min. Cut Out	No Timer	99 min. Cut Out	No Timer
Child Lock	-	Yes	-	Yes	Yes	Yes
Auto Safety Off (Auto Switch Off Safety-Gas)	-	Yes	-	-	Yes	-
Automatic Ignition	-	-	-	-	-	-
LPG Convertible	-	-	-	-	-	-
Residual Heat Indicator	Yes	Yes	Yes	Yes	Yes	Yes
Lead Supplied	Yes	Yes	Yes	Yes	Yes	Yes
Connection Type / amp	32 amp	40 amp	20 amp	20 amp	13amp - Fitted 3 Pin plug	32 amp
Dimensions Product (mm)	H65 W580 D510	H52 W770 D520	H53 W288 D520	H56 W290 D520	H77 W590 D520	H77 W590 D520
Dimensions Packed (mm)	H150 W630 D560	H145 W640 D870	H150 W370 D585	H134 W330 D573	H145 W660 D585	H150 W660 D585
Cut Out Dimensions (mm)	W560 D490	W740 D490	W268 D500	W270 D490	W560 D490	W560 D490
Air Gap Needed (mm)	50	50	50	50	50	50
Net Weight (kg)	9.8	8.8	4.5	4.5	9.5	9.5
EAN Number	5060217413333	5060217413812	0 607353755016	5055862318515	0 607353754996	0 607353755078

# Built-In Cooking | Hobs

Model Number	INT61T15	INT460F	INT785	INT901	GH30X	GH30BG	GH60X
Hob Type	Induction	Induction	Induction	Induction	Gas - Domino	Gas - Domino	Gas
Width (cm)	60	60	77	90	30	30	60
Total Power (W)	7000	6600-7200	6800-7400	6800-7400	4.0	4.0	7.5
Control Mode	Touch	Touch	Touch Controls	Touch Controls	Rotary Controls	Rotary Controls	Rotary Controls
Power Levels	9	9	9	9	-	-	-
Number of Zones/Burners	4	4	5	5	2	2	4
Front Left Zone Power (W)	2000	1400-1800 Boost	2000/2300 Boost	2000/2300 Boost	1000	1000	3000
Back Left Zone Power (W)	1500	1400-1800 Boost	1500	1500	3000	3000	1750
Front Right Zone Power (W)	1500	2100-2500 Boost	1500	1500	-	-	1000
Back Right Zone Power (W)	2000	1400/1800 Boost	2000/2300 Boost	2000/2300 Boost	-	-	1750
Central Zone Power (W)	-	-	2000/2300 Boost	2000/2300 Boost	-	-	-
ConnectCook	-	Yes - Left Side	-	-	-	-	-
Dual Zone	-	-	Yes	-	-	-	-
Pan Support Type	-	-	-	-	Cast Iron	Enamel	Enamel
Gas on Glass	-	-	-	-	-	Yes	-
Booster/Rapid Function	-	Yes	Booster - 3 Zones	Booster - 3 Zones	-	-	-
Timer	15 min. Cut Out	99 Min.	99 Min.	99 Min.	-	-	-
Child Lock	Yes	Yes	Yes	Yes	-	-	-
Auto Safety Off (Auto Switch Off Safety-Gas)	-	-	Yes	Yes	Yes	Yes	Yes
Automatic Ignition	-	-	-	-	Yes	Yes	Yes
LPG Convertible	-	-	-	-	Yes	Yes	Yes
Residual Heat Indicator	Yes	Yes	Yes	Yes	-	-	-
Lead Supplied	Yes	Yes	Yes	Yes	Yes	Yes	Yes
Connection Type / amp	32 amp	32 amp	32 amp	32 amp	-	-	-
Dimensions Product (mm)	H77 W590 D520	H53 W590 D520	H62 W770 D520	H62 W900 D520	H90 W300 D520	H90 W300 D520	H95 W590 D500
Dimensions Packed (mm)	H145 W660 D585	-	H145 W870 D640	H142 W1000 D650	H165 W355 D575	H165 W355 D575	H163 W647 D553
Cut Out Dimensions (mm)	W560 D490	W560 D490	W740 D490	W740 D490	W262 D492	W262 D492	W553 D473
Air Gap Needed (mm)	50	50	50	50	25	25	25
Net Weight (kg)	9.5	8.6	12.45	13.36	5.13	4.82	6.7
EAN Number	0 607353755023	5055862303603	5060217413999	5060217414309	5060217413616	5060217413630	5060217413609

# Built-In Cooking | Hobs

Model Number	GH60BG	GH61X	GH75BG	GH71X	GH90BG	GH91X
Hob Type	Gas	Gas	Gas	Gas	Gas	Gas
Width (cm)	60	60	70	70	90	90
Total Power (W)	7.5	7.5	10.8	10.8	10.8	10.8
Control Mode	Rotary Controls	Rotary Controls	Rotary Controls	Rotary Controls	Rotary Controls	Rotary Controls
Power Levels	-	-	-	-	-	-
Number of Zones/Burners	4	4	5	5	5	5
Front Left Zone Power (W)	3000	3000	1000	1000	1000	1000
Back Left Zone Power (W)	1750	1.75	3000	3000	3000	3000
Front Right Zone Power (W)	1000	1000	1750	1750	1750	1750
Back Right Zone Power (W)	1750	1750	1750	1750	1750	1750
Central Zone Power (W)	-	-	3300	3300	3300	3300
ConnectCook	-	-	-	-	-	-
Dual Zone	-	-	-	-	-	-
Pan Support Type	Cast Iron	Cast Iron	Cast Iron	Cast Iron	Cast Iron	Cast Iron
Gas on Glass	Yes	-	Yes	-	Yes	-
Booster/Rapid Function	-	-	-	-	-	-
Timer	-	-	-	-	-	-
Child Lock	-	-	-	-	-	-
Auto Safety Off (Auto Switch Off Safety-Gas)	Yes	Yes	Yes	Yes	Yes	Yes
Automatic Ignition	Yes	Yes	Yes	Yes	Yes	Yes
LPG Convertible	Yes	Yes	Yes	Yes	Yes	Yes
Residual Heat Indicator	-	-	-	-	-	-
Lead Supplied	Yes	Yes	Yes	Yes	Yes	Yes
Connection Type /Amp (Lead Supplied)	-	-	-	-	-	-
Dimensions Product (mm)	H110 W600 D510	H95 W590 D500	H95 W750 D520	H95 W750 D510	H100 W860 D520	H90 W860 D510
Dimensions Packed (mm)	H163 W647 D553	H163 W647 D553	H182 W837 D602	H182 W837 D602	H182 W932 D602	H182 W932 D602
Cut Out Dimensions (mm)	W553 D473	W553 D473	W560 D490	W560 D490	W815 D490	W815 D490
Air Gap Needed (mm)	25	25	25	25	25	25
Net Weight (kg)	12.45	8.5	15.1	12.9	18	14
EAN Number	5060217413623	5060217413593	5060217413562	5060217413579	5060217413555	5060217413586

# Built-In Cooking | Microwaves & Warming Drawer



## MWBIC90044\* Integrated Combi-Microwave

### Key Features:

- > Digital Display
- > Defrost Setting
- > 406mm Metal Turntable
- > 30 hr. Timer
- > Auto Cooking Progs.
- > 3D Hot Air Oven
- > Pull Down Door
- > Hard Wired
- > Stainless Steel & Black

**Microwave Power:** 900W  
**Grill Power:** 1750W | **Convection:** 2400W  
**Dimensions:** H460 W595 D476mm



Ventilation openings behind, base min.250cm<sup>2</sup>

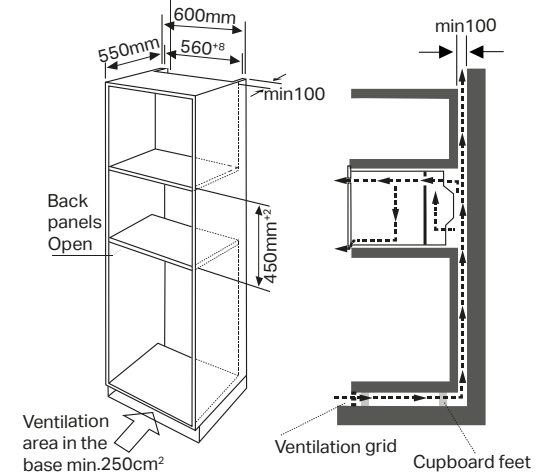

## MWBIC90029\* Integrated Combi-Microwave

### Key Features:

- > Digital Display
- > Defrost Setting
- > 315mm Glass Turntable
- > Auto Cooking Progs.
- > Trim Kit Included
- > Push Button Door Opening
- > Stainless Steel & Black

**Microwave Power:** 900W  
**Grill Power:** 1100W | **Convection:** 2400W  
**Dimensions:** H460 W595 D476mm

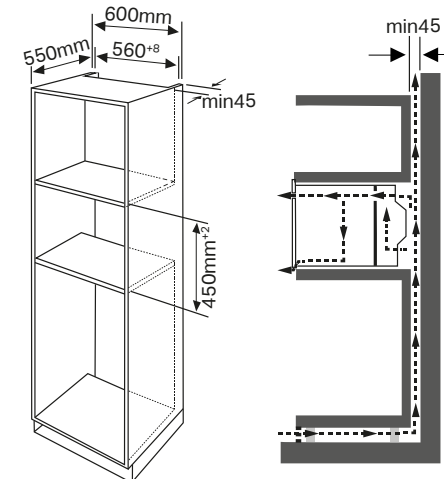

# Built-In Cooking | Microwaves & Warming Drawer



## MWBI90025\* Integrated Microwave & Grill

### Key Features:

- > Digital Display
- > Child Lock
- > 8 Auto Cooking Progs.
- > S/Steel Trim Kit Attached
- > Push Button Door Opening
- > Stainless Steel



**Microwave Power:** 900W  
**Grill Power:** 1000W  
**Dimensions:** H382 W595 D320mm

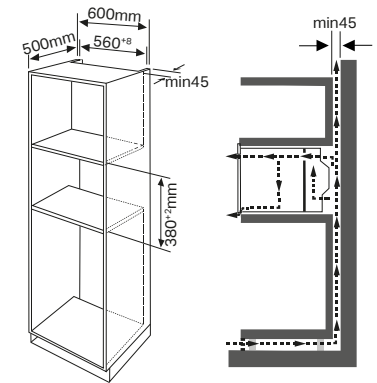

## MWBI17-300 Integrated Slim Depth Solo Microwave

### Key Features:

- > Digital Display
- > Child Lock
- > 5 Cooking Levels
- > Niche 300mm Deep
- > S/Steel Trim Kit Attached
- > Push Button Door Opening
- > Stainless Steel



**Microwave Power:** 700W  
**Grill Power:** N/A  
**Dimensions:** H388 W594 D300mm

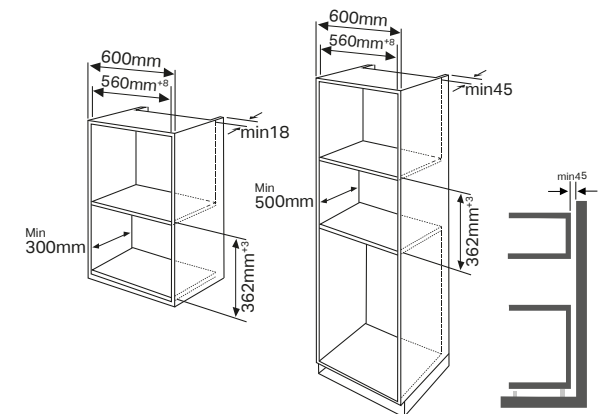

## WD14SS | WD14BK Integrated Warming Drawer

### Key Features:

- > 1000W
- > Adjustable Heat Setting
- > Touch Control
- > 3 Functions
- > Push Door Opening
- > Time Setting
- > Stainless Steel or Black

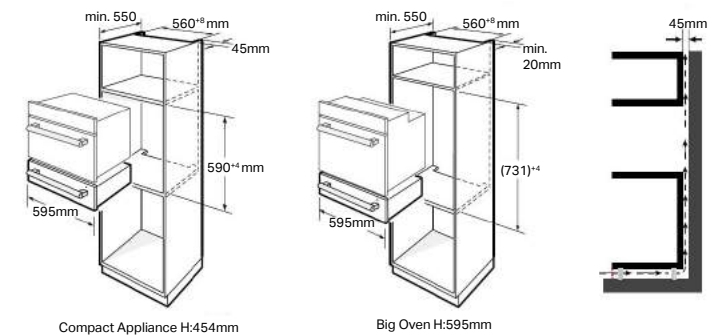

\* Whilst stocks last.

# Built-In Cooking | Microwaves & Warming Drawer

Model Number	MWBIC90044	MWBIC90029	MWBI90025	MWBI17-300	WD14SS/BK
Product Type	Combi Microwave	Combi Microwave	Microwave & Grill	Solo Microwave	Warming Drawer
Colour	Stainless & Black	Stainless & Black	Stainless Steel	Stainless Steel	Stainless Steel
Cavity Volume (ltr)	44	25	25	17	14
Cavity Type	Stainless Cavity	Stainless Cavity	Stainless Cavity	Stainless Cavity	Stainless Steel
Control Panel Type	LED	LED	LED	LED	Black
Controls	Knob & Button Control	Knob & Button Control	Knob & Button Control	Knob & Button Control	Touch Control
Child Safety Lock	Yes	Yes	Yes	Yes	N/A
Push Button Door Opening	No - Pull Down	Yes	Yes	Yes	Yes
Timer	30hr Timer	95 Min Timer	95 Min Timer	95 Min Timer	Yes
Number of Cooking Programmes	13	10	8	-	-
Number of Power Levels	5	5	5	5	3 Functions
Microwave Power (W)	900	900	900	700	-
Grill Power (W)	1750	1100	1000	-	-
Convection Power (W)	2400	2400	-	-	-
3D Hot Air	Yes	-	-	-	-
Keep Food Warm Function (WD14SS only)	-	-	-	-	Yes
Defrosting Function (WD14SS only)	-	-	-	-	Yes
Low Temperature Cooking 70°C (WD14 only)	-	-	-	-	Yes
UK Fitted Plug	No - Hard Wired	Yes	Yes	Yes	Yes
Net Weight (kg)	37	21.5	18	14.9	18
Gross Weight Packed (kg)	43	24	21	16.5	20.5
Turntable Diameter	406	315	315	245	-
Dimensions Product (mm)	H460 W595 D476	H460 W595 D476	H382 W595 D320	H388 W594 D300	H141 W595 D561
Dimensions Packed (mm)	H550 W670 D553	H550 W670 D553	H441 W650 D404	H441 W650 D404	H210 W705 D640
Dimensions Cabinet Size Required (mm)	N/A	N/A	N/A	H362 W560 D300	N/A
EAN Number	5060217413296	5060217413289	5060217412435	-	5060217413715

# Built-In Cooking | Hoods



## DDCH60 60cm Downdraft Hood

### Key Features:

- > 4 Speed Motor
- > 2 x 1W LED Lights
- > Aluminium & Charcoal Filters Inc.
- > Touch Controls
- > Motor Included
- > Stainless Steel



**Air Flow:** 430m<sup>3</sup>/h  
**Noise Level:** 62-67dB  
**Dimensions:** H335-718 W580 D115mm

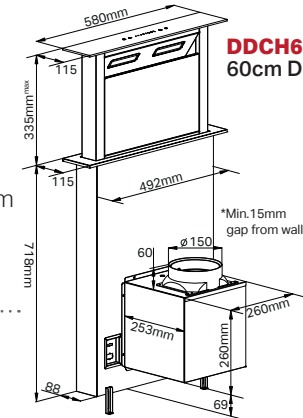

## DDCH60 60cm Downdraft Hood



## DDCH90 90cm Downdraft Hood

### Key Features:

- > 4 Speed Motor
- > 2 x 1W LED Lights
- > Aluminium & Charcoal Filters Inc.
- > Touch Controls
- > Motor Included
- > Stainless Steel



**Air Flow:** 430m<sup>3</sup>/h  
**Noise Level:** 62-67dB  
**Dimensions:** H335-718 W880 D115mm

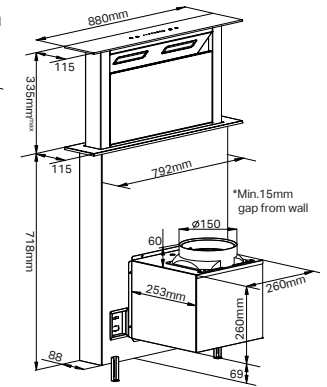

## DDCH90 90cm Downdraft Hood



## DCH7250BGT 50cm Slanted Hood

### Key Features:

- > 3 Speed Motor
- > 2 x 1W LED Lights
- > Touch Controls
- > Aluminium & Charcoal Filters Inc.
- > Black Glass



**Air Flow:** 350m<sup>3</sup>/h  
**Noise Level:** 66dB  
**Dimensions:** H780-1080 W500 D313mm

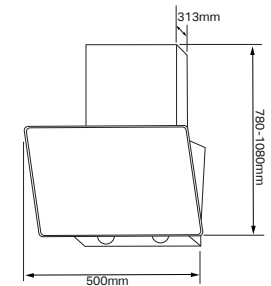

## DCH6760BGT 60cm Slanted Hood

### Key Features:

- > 3 Speed Motor
- > 2 x 1W LED Lights
- > Touch Controls
- > Aluminium & Charcoal Filters Inc.
- > Black Glass



**Air Flow:** 350m<sup>3</sup>/h  
**Noise Level:** 66dB  
**Dimensions:** H780-1080 W600 D313mm

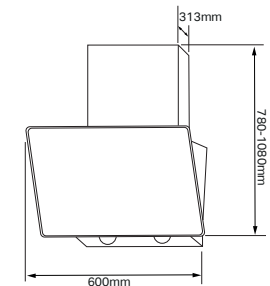

# Built-In Cooking | Hoods



## CHC612MSS | CHC612MB 60cm Chimney Hood

### Key Features:

- > 3 Speed Motor
- > LED Lamps
- > 2x Aluminium Filters Inc.
- > 1 x Charcoal Filter Inc.
- > Push Button Controls
- > Stainless Steel or Black



**Air Flow:** 350m<sup>3</sup>/h  
**Noise Level:** 63dB  
**Dimensions:** H780 W600 D465mm

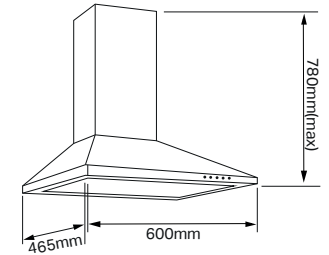

## CHC612BLKREM | CHC612MSSREM 60cm Chimney Hood

### Key Features:

- > 3 Speed Motor
- > LED Lights
- > 2 x Aluminium Filters Inc.
- > 1 x Charcoal Filter Inc.
- > Touch Controls + Remote
- > Stainless Steel or Black



**Air Flow:** 550m<sup>3</sup>/h  
**Noise Level:** 61dB  
**Dimensions:** H780 W600 D500mm

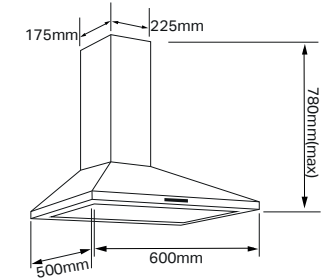

## CHC712MSS | CHC712MB 70cm Chimney Hood

### Key Features:

- > 3 Speed Motor
- > 2 x 2W LED Lights
- > 2 x Aluminium Filters Inc.
- > 1 x Charcoal Filter Inc.
- > Push Button Controls
- > Stainless Steel or Black



**Air Flow:** 350m<sup>3</sup>/h  
**Noise Level:** 63dB  
**Dimensions:** H960 W700 D465mm

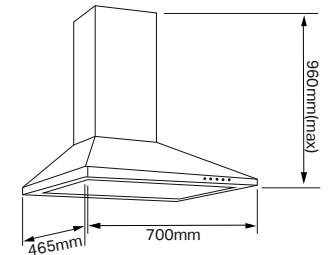

## CHC912MSS | CHC912BLK 90cm Chimney Hood

### Key Features:

- > 3 Speed Motor
- > 2 x 2W LED Lights
- > 3 x Aluminium Filters Inc.
- > 1 x Charcoal Filter Inc.
- > Push Button Controls
- > Stainless Steel or Black



**Air Flow:** 350m<sup>3</sup>/h  
**Noise Level:** 63dB  
**Dimensions:** H960 W900 D465mm

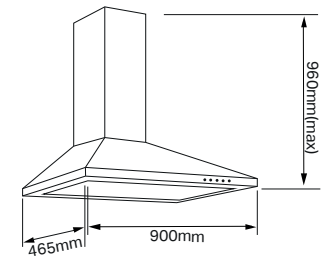



# Built-In Cooking | Hoods

## CHC1012MSS | CHC1012BLK 100cm Chimney Hood



### Key Features:

- > 3 Speed Motor
- > 2 x 2W LED Lights
- > 3 x Aluminium Filters Inc.
- > 1 x Charcoal Filter Inc.
- > Push Button Controls
- > Stainless Steel or Black



**Air Flow:** 550m<sup>3</sup>/h  
**Noise Level:** 61dB  
**Dimensions:** H780 W1000 D500mm

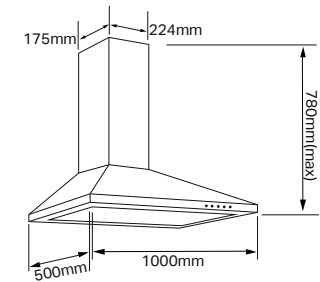

## CHC1012MSSREM 100cm Chimney Hood



### Key Features:

- > 3 Speed Motor
- > 2 x 2W LED Lights
- > 3 x Aluminium Filters Inc.
- > 1 x Charcoal Filter Inc.
- > Touch Controls + Remote
- > Stainless Steel or Black



**Air Flow:** 550m<sup>3</sup>/h  
**Noise Level:** 61dB  
**Dimensions:** H780 W1000 D500mm

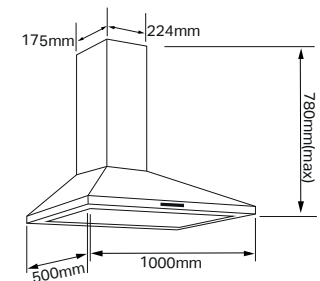

## CHG613MSS-EDGE | CHG613MB-EDGE 60cm Curved Glass Hood



### Key Features:

- > 3 Speed Motor
- > 2 x 1.5W LED Lights
- > Red, Green & Blue LED Edge Lighting
- > 1 x Aluminium Filter Inc.
- > 1 x Charcoal Filter Inc.
- > Push Button Controls
- > Stainless Steel or Black



**Air Flow:** 400m<sup>3</sup>/h  
**Noise Level:** 67dB  
**Dimensions:** 430-H730 W600 D450mm

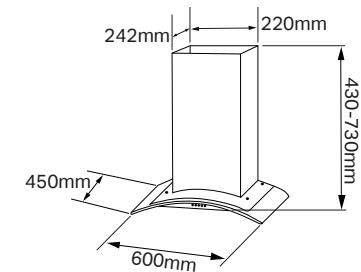

## CHG613MSS 60cm Curved Glass Hood



### Key Features:

- > 3 Speed Motor
- > LED Lights
- > 1 x Aluminium Filter Inc.
- > 1 x Charcoal Filter Inc.
- > Push Button Controls
- > Stainless Steel & Glass



**Air Flow:** 350m<sup>3</sup>/h  
**Noise Level:** 61dB  
**Dimensions:** H780 W600 D500mm

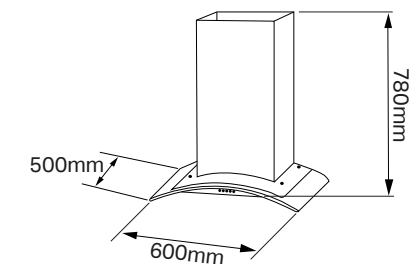

# Built-In Cooking | Hoods



## CHG713MSS 70cm Curved Glass Hood

### Key Features:

- > 3 Speed Motor
- > LED Lights
- > 1 x Aluminium Filters Inc.
- > 1 x Charcoal Filter Inc.
- > Push Button Controls
- > Stainless Steel & Glass



**Air Flow:** 338.4m<sup>3</sup>/h  
**Noise Level:** 63dB  
**Dimensions:** H840 W700 D470mm

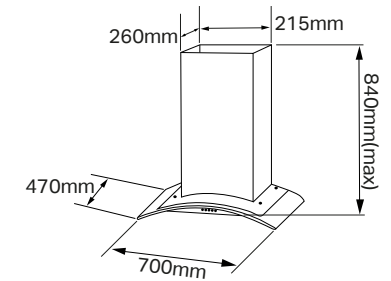

## CHG913MSS 90cm Curved Glass Hood

### Key Features:

- > 3 Speeds
- > LED Lights
- > 1 x Aluminium Filter Inc.
- > 1 x Charcoal Filter Inc.
- > Push Button Controls
- > Stainless Steel



**Air Flow:** 400m<sup>3</sup>/h  
**Noise Level:** 66dB  
**Dimensions:** H430-730 W900 D450mm

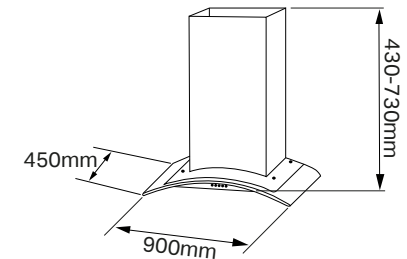

## CHT0660 60cm T-Shaped Hood

### Key Features:

- > 3 Speeds
- > 2 x 1.5W LED Lights
- > 2 x Aluminium Filters Inc.
- > 1 x Charcoal Filter Inc.
- > Touch Controls
- > Stainless Steel



**Air Flow:** 550m<sup>3</sup>/h  
**Noise Level:** 69dB  
**Dimensions:** H450-820 W600 D450mm

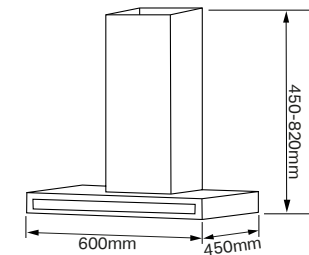

## CHT0670 70cm T-Shaped Hood

### Key Features:

- > 3 Speeds
- > 2 x 1.5W LED Lights
- > 2 x Aluminium Filters Inc.
- > 1 x Charcoal Filter Inc.
- > Touch Controls
- > Stainless Steel



**Air Flow:** 550m<sup>3</sup>/h  
**Noise Level:** 62dB  
**Dimensions:** H780 W700 D500mm

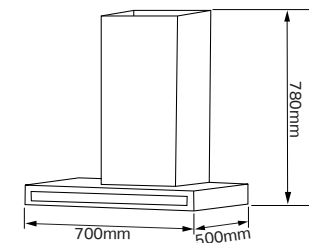

# Built-In Cooking | Hoods

## CHT0690 90cm T-Shaped Hood



### Key Features:

- > 3 Speeds
- > 2 x 1.5W LED Lights
- > 2 x Aluminium Filters Inc.
- > 1 x Charcoal Filter Inc.
- > Touch Controls
- > Stainless Steel



**Air Flow:** 550m<sup>3</sup>/h  
**Noise Level:** 71dB  
**Dimensions:** H780 W900 D500mm

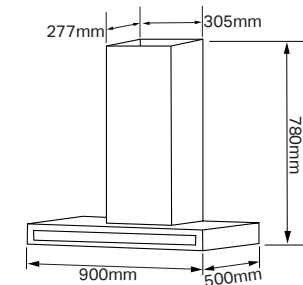

## CHT991PB | CHT991CR 90cm T-Shaped Hood



### Key Features:

- > 3 Speed Motor
- > LED Lights
- > 2 x Aluminium Filters Inc.
- > Push Button Controls
- > Pastel Blue or Cream

(recommended pairing: 90cm dual fuel range cooker in pastel blue and cream)



MR95DFPB



MR95DFCR



**Air Flow:** 580m<sup>3</sup>/h  
**Noise Level:** 71 dB  
**Dimensions:** H655-1035 W898 D500mm

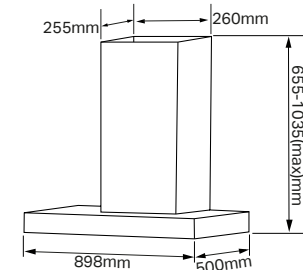

## CHT991X 90cm T-Shaped Hood



### Key Features:

- > 3 Speed Motor
- > 2 x 1W LED Lights
- > Touch Controls
- > Carbon & Aluminium Filter Inc.
- > Stainless Steel

(recommended pairing: 90cm dual fuel range cooker in stainless steel with mirror glass)



MRT91DFMX



**Air Flow:** 334.9m<sup>3</sup>/h  
**Noise Level:** 69dB  
**Dimensions:** H450-820 W900 D450mm

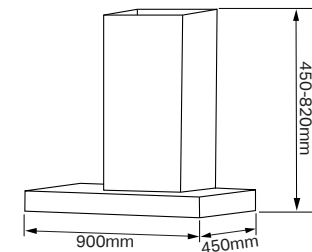

## ICHT02101 90cm Island Hood



### Key Features:

- > 3 Speed Motor
- > 4 x 1W LED Lights
- > Carbon & Aluminium Filters Inc.
- > Touch Controls
- > Stainless Steel



**Air Flow:** 600m<sup>3</sup>/h  
**Noise Level:** 69dB  
**Dimensions:** H700-1010 W900 D610mm

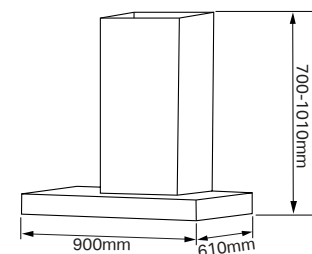

# Built-In Cooking | Hoods



## ICHC2390S 38cm Cylinder Island Hood

### Key Features:

- > 3 Speed Motor
- > LED Light Panels
- > 1 x Aluminium Filter Inc.
- > 1 x Carbon Filter Inc.
- > Electronic Controls
- > Stainless Steel



**Air Flow:** 550m<sup>3</sup>/h  
**Noise Level:** 58dB  
**Dimensions:** H970 W380 D380mm

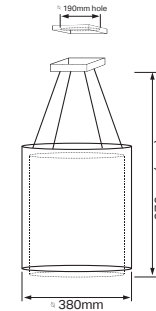

## ICHC2590L 47cm Cylinder Island Hood

### Key Features:

- > 3 Speed Motor
- > 2 x 1W LED Light Panels
- > 1 x Aluminium Filter Inc.
- > 1 x Carbon Filter Inc.
- > Electronic Controls
- > Stainless Steel



**Air Flow:** 550m<sup>3</sup>/h  
**Noise Level:** 58dB  
**Dimensions:** H960 W465 D465mm

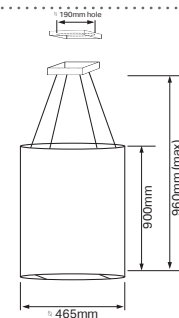

## ICHG0760 57cm Cylinder Island Hood

### Key Features:

- > 3 Speed Motor
- > 2 x 1.5W LED Lights
- > 1 x Aluminium Filter Inc.
- > 1 x Charcoal Filter Inc.
- > Electronic Controls
- > Stainless Steel & Glass



**Air Flow:** 400m<sup>3</sup>/h  
**Noise Level:** 58dB  
**Dimensions:** H1190 W573 D556mm

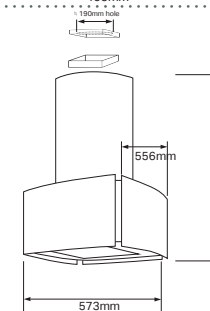

## CACH510 52cm Canopy Hood

### Key Features:

- > 3 Speed Motor
- > 2 x 3W LED
- > Slide Controls
- > Aluminium & Carbon Filters Inc.



**Air Flow:** 424.1m<sup>3</sup>/h  
**Noise Level:** 57dB  
**Dimensions:** H254 W520 D296mm

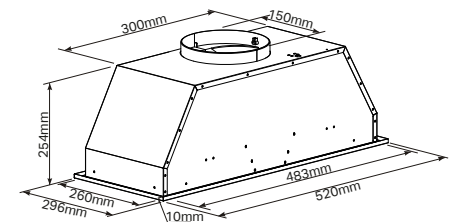

# Built-In Cooking | Hoods

## CHV611MW | CHV611SS 60cm Visor Hood



### Key Features:

- > 3 Speeds
- > 1 x 2W LED Lights
- > 2 x Aluminium Filters Inc.
- > 1 x Charcoal Filter Inc.
- > Button Controls
- > White or Stainless Steel



**Air Flow:** 200m<sup>3</sup>/h  
**Noise Level:** 60dB  
**Dimensions:** H820 W600 D480mm

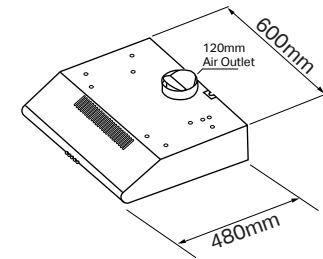

## SWCH501 60cm Swing Out Hood



### Key Features:

- > 3 Speed Motor
- > 1 x 40W Light
- > Acrylic & Charcoal Filters Inc.
- > Slide Controls
- > Grey



**Air Flow:** 352m<sup>3</sup>/h  
**Noise Level:** 60/68dB  
**Dimensions:** H395 W600 D282mm

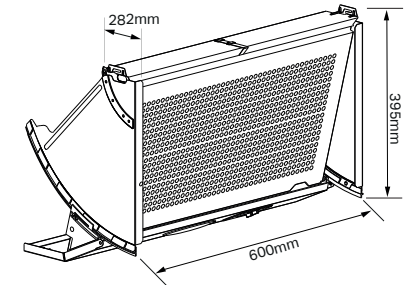

## TCH260 60cm Telescopic Hood



### Key Features:

- > 3 Speeds
- > 2 x 2W LED Lights
- > Electronic Touch Control
- > Stainless Steel



**Air Flow:** 350m<sup>3</sup>/h  
**Noise Level:** 64dB  
**Dimensions:** H194 W600 D248-480mm

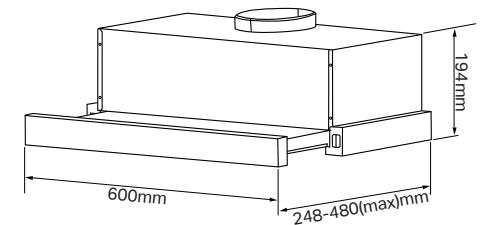

## TCH290 90cm Telescopic Hood



### Key Features:

- > 3 Speeds
- > 2 x 2W LED Lights
- > Electronic Touch Control
- > Stainless Steel



**Air Flow:** 350m<sup>3</sup>/h  
**Noise Level:** 64dB  
**Dimensions:** H194 W900 D248-480mm

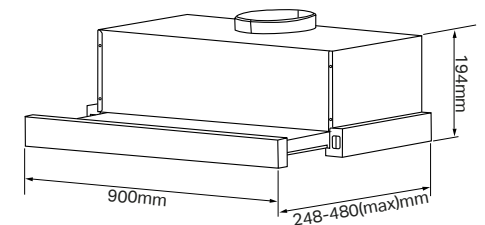

# Built-In Cooking | Hoods

Model Number	DDCH60	DDCH90	DCH7250BGT	DCH6760BGT	CHC612MSS CHC612MB	CHC612MSSREM CHC612BLKREM
Width (cm)	60	90	50	60	60	60
Finish	Stainless Steel	Stainless Steel	Black Glass	Black Glass	Stainless Steel or Black	Stainless Steel or Black
Category Type	Downdraft	Downdraft	Slanted	Slanted	Chimney	Chimney
Motor Power (W)	190	190	110	110	65	100
Noise Level (dB)	62/67	62/67	66	66	63	61
Airflow Rate (m³/h)	430	539	350	350	350	550
Speeds	4	4	3	3	3	3
Control Type	Touch	Touch	Touch	Touch	Push Button	Touch
Remote Control	-	-	-	-	-	Yes
Lamp Type	LED	LED	LED	LED	LED	LED
Filters Included	Aluminium & Charcoal	Aluminium & Charcoal	Aluminium & Charcoal	Aluminium & Charcoal	Aluminium & Charcoal	Aluminium & Charcoal
Duct Kit Included	-	-	Yes - 120 mm	Yes - 120 mm	-	Yes - 150 mm
Reducer Included (mm)	Yes - 150-120	Yes - 150-120	Yes - 150-120	Yes - 150-120	Yes - 150-120	Yes - 150-120
Fixing Kit Included	Yes	Yes	Yes	Yes	Yes	Yes
UK Fitted Plug	Yes - 3AMP	Yes - 3AMP	Yes - 3AMP	Yes - 3AMP	Yes - 3AMP	Yes - 3AMP
Guarantee	2 Years P & L	2 Years P & L	2 Years P & L	2 Years P & L	2 Years P & L	2 Years P & L
Net Weight Product (kg)	23.6	28	-	-	7	11.5
Gross Weight Packaged (kg)	28.5	35	-	-	8.5	13
Dimensions Product (mm)	H335/718 W580 D115	H335/718 W880 D115	H780-1080 W500 D313mm	H780-1080 W600 D313mm	H780 W600 D465	H780 W600 D500
Dimensions Packed (mm)	H805 W665 D490	H805 W965 D490	-	-	H250 W650 D520	H325 W655 D555
EAN Number	50602174413869	5060217413876	0 727542515112	0 727542515129	S/S- 5060217414606 Black-5060217414583	S/S-5060217414613 Black-5060217414378

# Built-In Cooking | Hoods

Model Number	CHC712MSS CHC712MB	CHC912MSS CHC912BLK	CHC1012MSS CHC1012BLK	CHC1012MSSREM	CHG613MSS-Edge CHG613MB-Edge	CHG613MSS
Width (cm)	70	90	100	100	60	60
Finish	Stainless Steel or Black	Stainless Steel or Black	Stainless Steel or Black	Stainless Steel	Stainless Steel or Black & Glass	Stainless Steel & Glass
Category Type	Chimney	Chimney	Chimney	Chimney	Curved Glass	Curved Glass
Motor Power (W)	65	65	100	100	25	65
Noise Level (dB)	63	63	61	61	67	61
Airflow Rate (m³/h)	350	350	550	550	400	350
Speeds	3	3	3	3	3	3
Control Type	Push Button	Push Button	Push Button	Touch Controls	Push Button	Push Button
Remote Control	-	-	-	Yes	-	-
Lamp Type	LED	LED	LED	LED	LED	LED
Filters Included	Aluminium & Charcoal	Aluminium & Charcoal	Aluminium & Charcoal	Aluminium & Charcoal	Aluminium & Charcoal	Aluminium & Charcoal
Duct Kit Included	Yes - 150 mm	Yes - 150 mm	Yes - 150 mm	Yes - 150 mm	Yes	Yes - 150 mm
Reducer Included	Yes - 150-120	Yes - 150-120	Yes - 150-120	Yes - 150-120	Yes - 150-120	Yes - 150-120
Fixing Kit Included	Yes	Yes	Yes	Yes	Yes	Yes
UK Fitted Plug	Yes - 3AMP	Yes - 3AMP	Yes - 3AMP	Yes - 3AMP	Yes - 3AMP	Yes - 3AMP
Guarantee	2 Years P & L	2 Years P & L	2 Years P & L	2 Years P & L	2 Years P & L	2 Years P & L
Net Weight Product (kg)	7.5	9	12.2	12.7	8	10.5
Gross Weight Packaged (kg)	9	10.5	14.7	15.5	10	12
Dimensions Product (mm)	H960 W700 D465	H960 W900 D465	H780 W1000 D500	H780 W1000 D500	H430-730 W600 D450	H780 W600 D500
Dimensions Packed (mm)	H250 W750 D520	H250 W950 D520	H325 W1055 D550	H325 W1055 D550	H250 W650 D490	H295 W655 D555
EAN Number	S/S-5060217414385 Black-5060217414552	S/S-5060217414576 Black-506021744415	S/S-5060217414408 Black-5060217414392	5060217414361	MSS-0 607353754989 MB-0 607353754972	5060217414347

# Built-In Cooking | Hoods

Model Number	CHG713MSS	CHG913MSS	CHT0660	CHT0670	CHT0690	CHT991PB CHT991CR
Width (cm)	70	90	60	70	90	60
Finish	Stainless Steel & Glass	Stainless Steel & Glass	Stainless Steel	Stainless Steel	Stainless Steel	Pastel Blue or Cream
Category Type	Curved Glass	Curved Glass	T-Shaped	T-Shaped	T-Shaped	T-Shaped
Motor Power (W)	65	25	120	100	165	-
Noise Level (dB)	63	66	69	62	71	71
Airflow Rate (m <sup>3</sup> /h)	338.4	400	550	550	550	580
Speeds	3	3	3	3	3	3
Control Type	Push Button	Push Button	Touch	Electronic Touch	Electronic Touch	Push Button
Remote Control	-	-	-	-	-	-
Lamp Type	2 x 1.5W LED Lights	2 x 1W LED Lights	LED	LED	LED	LED
Filters Included	Aluminium & Charcoal	Aluminium & Charcoal	Aluminium & Charcoal	Aluminium & Charcoal	Aluminium & Charcoal	Aluminium
Duct Kit Included	180mm	150mm	-	-	-	-
Reducer Included	Yes - 150-120	Yes - 150-120	Yes - 150-120	Yes - 150-120	Yes - 150-120	Yes - 150-120
Fixing Kit Included	Yes	Yes	Yes	Yes	Yes	Yes
UK Fitted Plug	Yes - 3AMP	Yes - 3AMP	Yes - 3AMP	Yes - 3AMP	Yes - 3AMP	Yes - 3AMP
Guarantee	2 Years P & L	2 Years P & L	2 Years P & L	2 Years P & L	2 Years P & L	2 Years P & L
Net Weight Product (kg)	10	11.5	14	15	16	-
Gross Weight Packaged (kg)	11	14	16	17	18	18.2
Dimensions Product (mm)	H840 W700 D470	H430-730 W950 D520	H840 W650 D450	H780 W700 D500	H780 W900 D500	H655-1035 W900 D500
Dimensions Packed (mm)	H505 W210 D305	-	H400 W655 D550	H400 W755 D550	H400 W955 D550	-
EAN Number	-	0 727542515136	5060217414521	5060217414514	5060217414507	PB-5604409146304 CR-5604409146311



# Built-In Cooking | Hoods

Model Number	CHT991X	ICHT02101	ICHC2390S	ICHC2590L	ICHG0760
Width (cm)	90	90	38	90	90
Finish	Stainless Steel	Stainless	Stainless Steel	Stainless Steel	Stainless Steel
Category Type	T-Shaped	Island	Cylinder Island	Cylinder Island	Cylinder Island
Motor Power (W)	120	110	165	165	165
Noise Level (dB)	69	69	58	58	58
Airflow Rate (m³/h)	334.9	600	550	550	400
Speeds	3	3	3	3	3
Control Type	Touch	Electronic Touch	Electronic	Electronic	Electronic
Remote Control	-	-	-	-	-
Lamp Type	LED	LED	LED	LED	LED
Filters Included	Carbon & Aluminium	Carbon & Aluminium	Carbon & Aluminium	Carbon & Aluminium	Carbon & Aluminium
Duct Kit Included	-	Yes	-	-	-
Reducer Included	Yes - 150-120	Yes - 150 - 120	Yes - 150-120	Yes - 150-120	Yes - 150 mm
Fixing Kit Included	Yes	Yes	Yes	Yes	Yes
UK Fitted Plug	Yes - 3AMP	Yes - 3AMP	Yes - 3AMP	Yes - 3AMP	Yes - 3AMP
Guarantee	2 Years P & L	2 Years P & L	2 Years P & L	2 Years P & L	2 Years P & L
Net Weight Product (kg)	-	12	15.5	23.7	30.5
Gross Weight Packaged (kg)	-	21.5	21.8	28	35.5
Dimensions Product (mm)	H450-820 W900 W450	H700-1010 W900 D610	H970(max) W380 D380	H960 (max) W900 D465	H1190 (max) W573 D556
Dimensions Packed (mm)	-	-	H440 W520 D440	H440 W660 D440	H1055 W660 D611
EAN Number	-	0 727542515167	5060217414477	5060217414460	-

# Built-In Cooking | Hoods

Model Number	CACH510	CHV611MW CHV611SS	SWCH501	TCH260	TCH290
Width (cm)	52	60	60	60	90
Finish	Stainless Steel	Stainless Steel or White	Grey	Stainless Steel	Stainless Steel
Category Type	Canopy	Visor	Swing-Out	Telescopic	Telescopic
Motor Power (W)	100	65	2 x 100	69	69
Noise Level (dB)	57	60	60/68	64	64
Airflow Rate (m <sup>3</sup> /h)	424.1	200	352	350	350
Speeds	3	3	3	3	3
Control Type	Manual - Slide	Push Button	Slide	Electronic Touch	Electronic Touch
Remote Control	-	-	-	-	-
Lamp Type	LED	LED	1 x 40	LED	LED
Filters Included	Carbon & Aluminium	Yes - Carbon & Aluminium	Acrylic & Charcoal	Yes - Carbon & Aluminium	Yes - Carbon & Aluminium
Duct Kit Included	Yes	-	-	-	-
Reducer Included	-	-	-	-	-
Fixing Kit Included	Yes	Yes	Yes	Yes	Yes
UK Fitted Plug	Yes - 3AMP	Yes - 3AMP	Yes - 3AMP	Yes - 3AMP	Yes - 3AMP
Guarantee	2 Years P & L	2 Years P & L	2 Years P & L	2 Years P & L	2 Years P & L
Net Weight Product (kg)	5.8	7	8.5	6	8.5
Gross Weight Packaged (kg)	7	8	10	7	10
Dimensions Product (mm)	H254 W520 D296	H820 W600 D480	H395 W600 D282	H194 W600 D248-480	H194 W900 D248-480
Dimensions Packed (mm)	-	H140 W645 D530	H515 W645 D255	H250 W635 D370	H250 W935 D370
EAN Number	-	S/S-5060217414453 Black-5060217413883	-	5060217414545	5060217414538

# Splash Backs

## 60cm Glass Splash Back

SP6075AL | SP6075BS | SP6075GM | SP6075MB | SP6075SM



Dimensions	H750 W600mm
Colour	Black Stars   Midnight Black   Gun Metal   Alloy Metal   Smoke Finish

## 90cm Glass Splash Back

SP9075AL | SP9075BS | SP9075GM | SP9075MB | SP9075SM

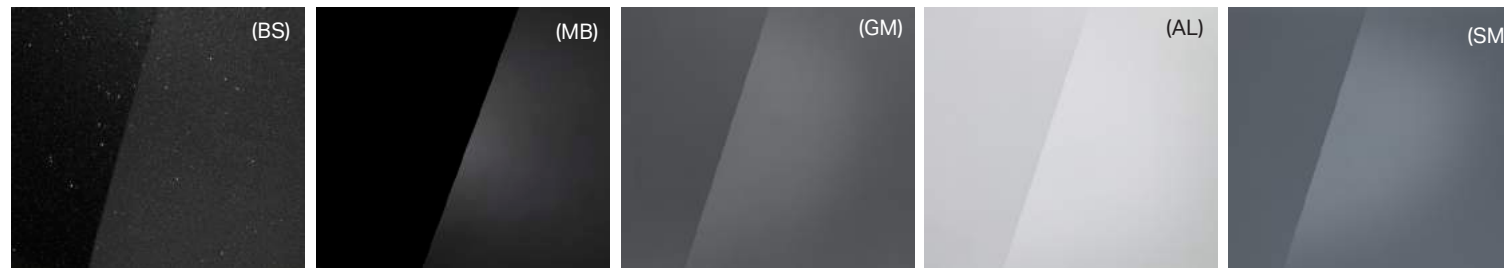

Dimensions	H750 W900mm
Colour	Black Stars   Midnight Black   Gun Metal   Alloy Metal   Smoke Finish

## Montpellier Adhesive



10 year guarantee given when a Montpellier Splash Back is fitted using the Montpellier approved adhesive.

**10  
YEAR  
GUARANTEE**  
— PARTS & LABOUR —

# Built-In Cooling I



## MIFF501 Built-In Fridge Freezer

### Key Features:

- > 50/50 Split
- > Adjustable Glass Shelves
- > 1 Salad Crisper Drawer
- > Tall Bottle Door Storage
- > Fridge Light
- > 4 Freezer Compartments
- > Reversible Door



**Annual Energy Consumption:** 291kWh

**Fixing Type:** Slider Fixing

**Dimensions:** H1781 W540 D545mm

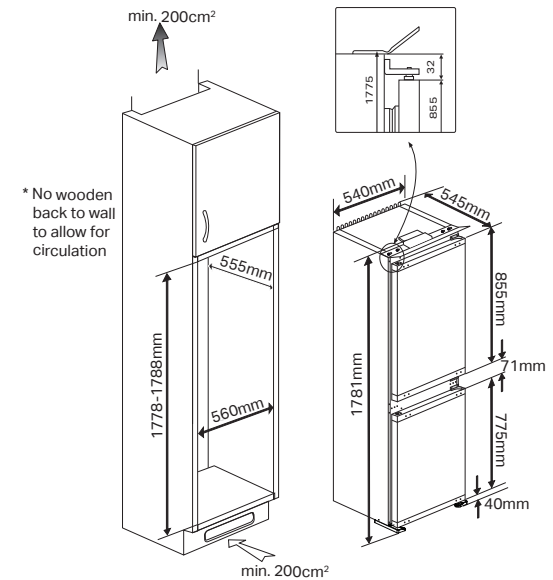

## MIFF501F Built-In Fridge Freezer

### Key Features:

- > 50/50 Split
- > Frost Free
- > Adjustable Glass Shelves
- > 1 Salad Crisper Drawer
- > Tall Bottle Door Storage
- > Fridge Light
- > 4 Freezer Compartments
- > Reversible Door



**Annual Energy Consumption:** 298kWh

**Fixing Type:** Slider Fixing

**Dimensions:** H1781 W540 D545mm

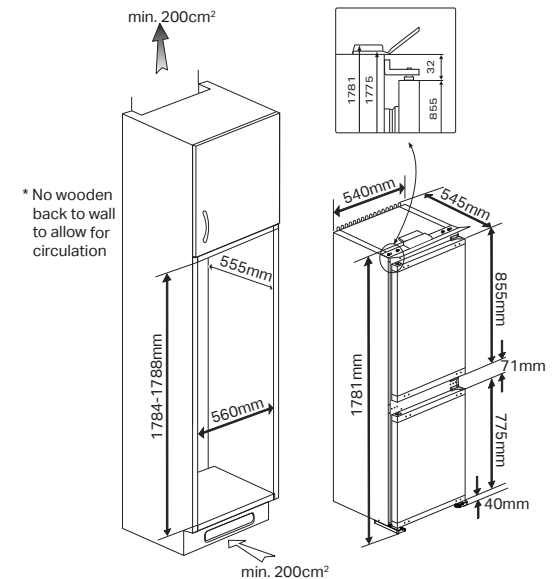

# Built-In Cooling |



## MIFF701 Built-In Fridge Freezer

### Key Features:

- > 70/30 Split
- > Adjustable Glass Shelves
- > 1 Salad Crisper Drawer
- > Tall Bottle Door Storage
- > Fridge Light
- > 3 Freezer Compartments
- > Reversible Door



**Annual Energy Consumption:** 282kWh  
**Fixing Type:** Slider Fixing  
**Dimensions:** H1781 W540 D545mm

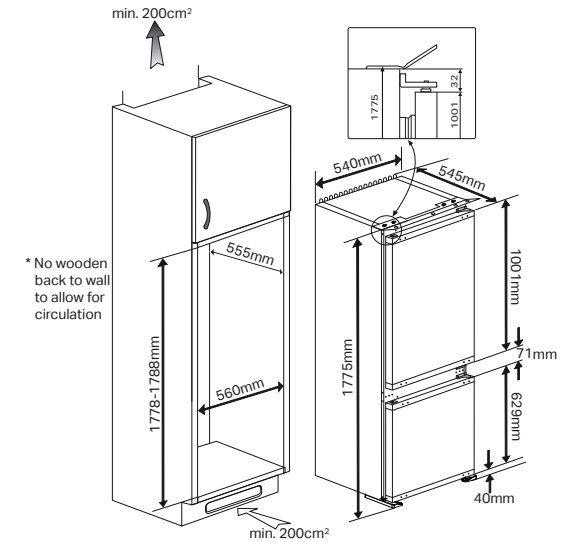

## MIFF7301F Built-In Fridge Freezer

### Key Features:

- > 70/30 Split
- > Frost Free
- > Adjustable Glass Shelves
- > 1 Salad Crisper Drawer
- > Tall Bottle Door Storage
- > Fridge Light
- > 3 Freezer Compartments
- > Reversible Door



**Annual Energy Consumption:** 286kWh  
**Fixing Type:** Slider Fixing  
**Dimensions:** H1781 W540 D545mm

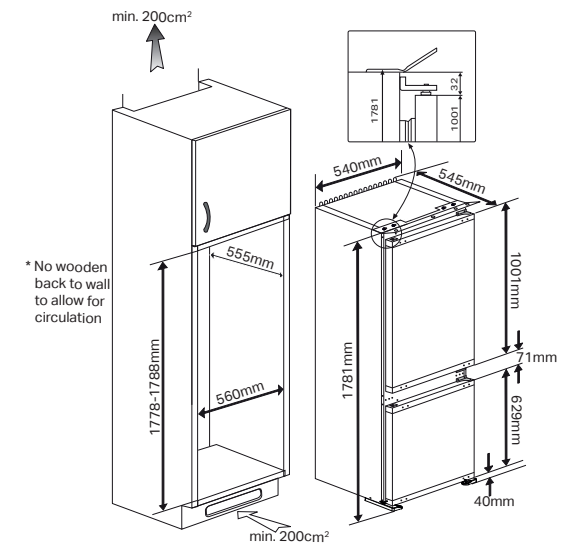

# Built-In Cooling |



## MICL88 In-Column Larder Fridge

### Key Features:

- > Glass Shelves
- > Chrome Wine Rack
- > 2 Salad Crisper Drawers
- > Door Storage
- > LED Light
- > Reversible Door



**Annual Energy Consumption:** 121kWh

**Fixing Type:** Slider Fixing

**Dimensions:** H875 W540 D545mm

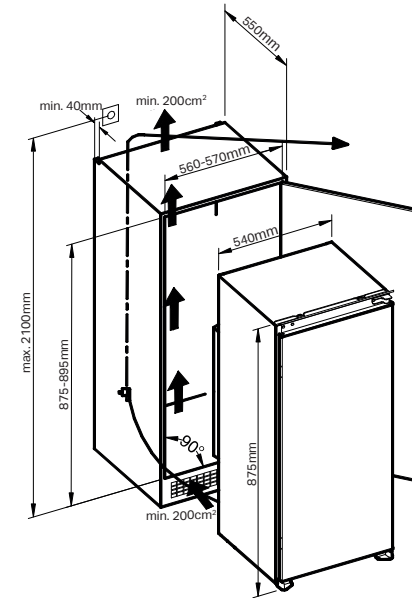

## MICF88 In-Column Freezer

### Key Features:

- > 4 Compartments
- > 4\* Freezer Rating
- > Reversible Door



**Annual Energy Consumption:** 195kWh

**Fixing Type:** Slider Fixing

**Dimensions:** H875 W540 D545mm

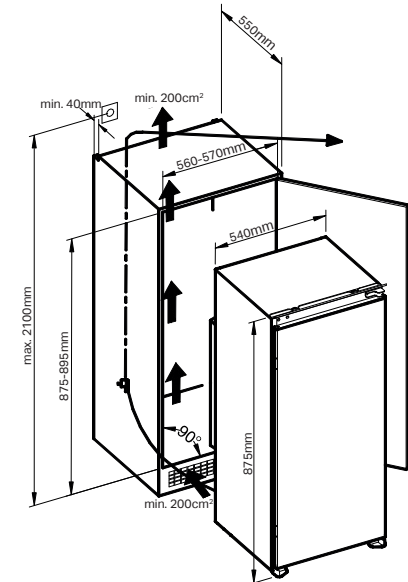

# Built-In Cooling |



## MICL122 Integrated Larder Fridge

### Key Features:

- > Glass Shelves
- > Chrome Wine Rack
- > 2 Salad Crisper Drawers
- > Door Storage
- > LED Light
- > Reversible Door



**Annual Energy Consumption:** 126kWh

**Fixing Type:** Slider Fixing

**Dimensions:** H1225 W540 D545mm

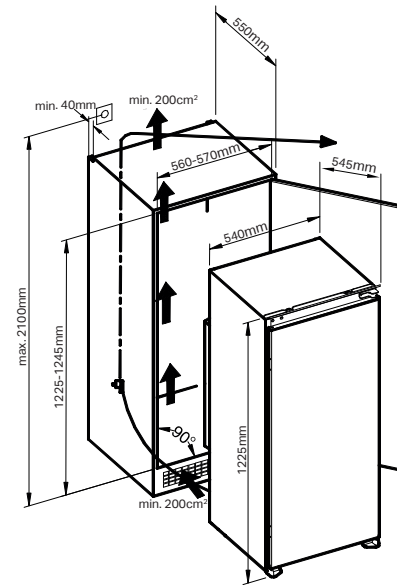

## MICR122 Integrated Icebox Fridge

### Key Features:

- > Glass Shelves
- > Chrome Wine Rack
- > 2 Salad Crisper Drawers
- > LED Light
- > 4\* Icebox
- > Reversible Door



**Annual Energy Consumption:** 209kWh

**Fixing Type:** Slider Fixing

**Dimensions:** H1225 W540 D545mm

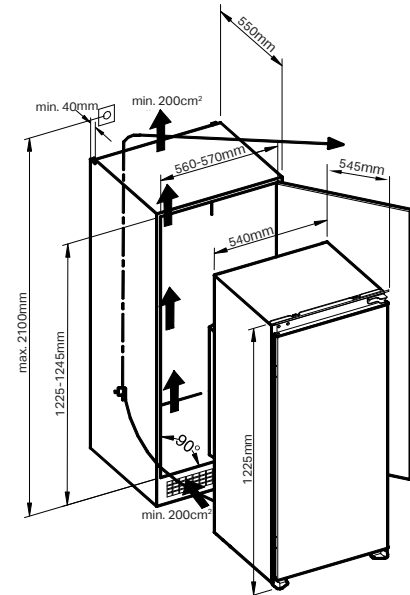

# Built-In Cooling |



## MITL100 Integrated Tall Larder Fridge

### Key Features:

- > Glass Shelves
- > Chrome Wine Rack
- > Humidity Controlled Crisper
- > +2 - +8°C Temp. Range
- > Humidity Control
- > LED Light
- > Reversible Door



**Annual Energy Consumption:** 141kWh  
**Fixing Type:** Door-On-Door Fixing  
**Dimensions:** H1770 W540 D545mm

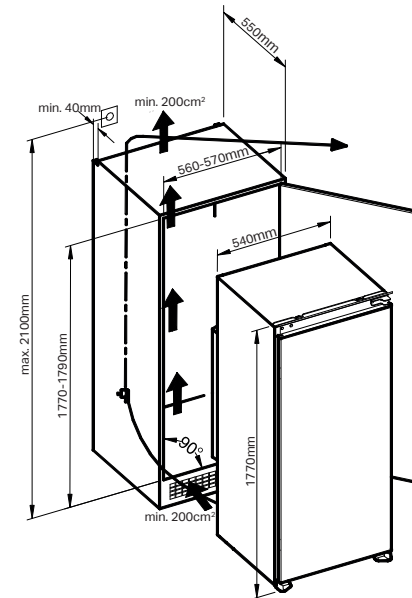

## MITF300 Integrated Tall Freezer

### Key Features:

- > Frost Free
- > 7 Compartments +1 Flap
- > 4\* Freezer Rating
- > Auto Defrost
- > -16-24°C Temp. Range
- > LED Lighting



**Annual Energy Consumption:** 283kWh  
**Fixing Type:** Door-On-Door Fixing  
**Dimensions:** H1770 W540 D545mm

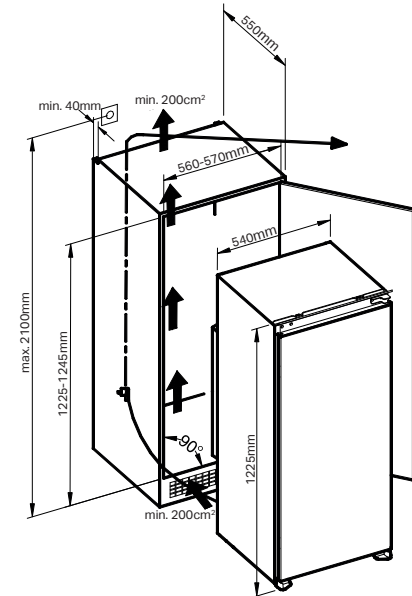



# Built-In Cooling |



## **MBUL100** Built-Under Larder Fridge

### Key Features:

- > Glass Shelves
- > Auto Defrost
- > Concealed Compartment
- > Fridge Light
- > Reversible Door



**Annual Energy Consumption:** 117kWh  
**Fixing Type:** Door-On-Door Fixing  
**Dimensions:** H820-870 W595 D545mm

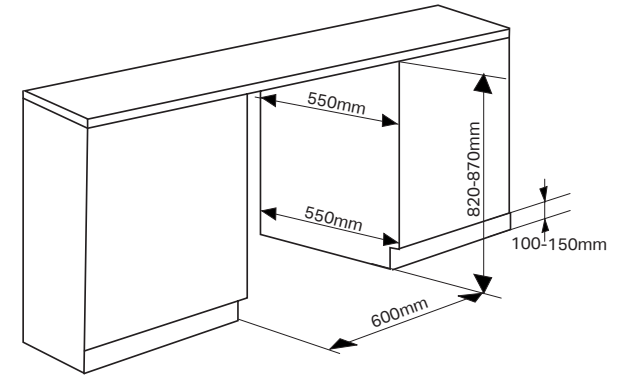

## **MBUR200** Built-Under Icebox Fridge

### Key Features:

- > Glass Shelves
- > Auto Defrost
- > Concealed Compartment
- > Fridge Light
- > 4\* Icebox
- > Reversible Door



**Annual Energy Consumption:** 183kWh  
**Fixing Type:** Door-On-Door Fixing  
**Dimensions:** H820-870 W595 D545mm

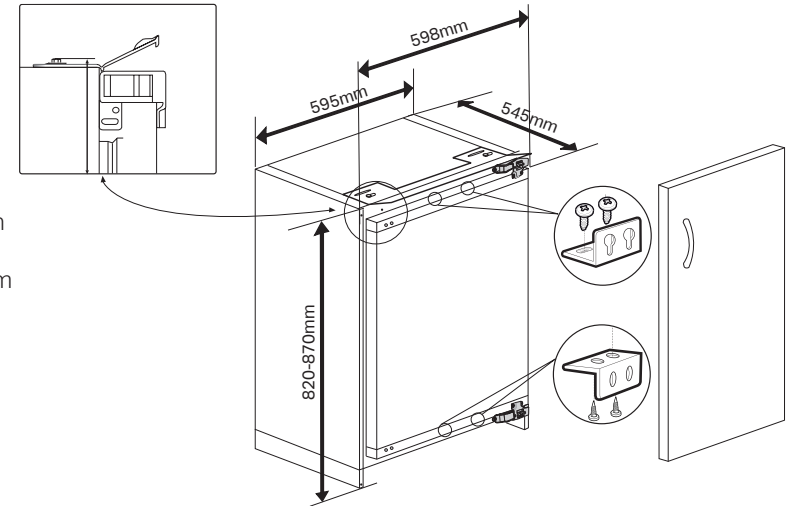

## **MBUF300** Built-Under Freezer

### Key Features:

- > 3 Compartments
- > Warning Lights
- > Reversible Door



**Annual Energy Consumption:** 183kWh  
**Fixing Type:** Door-On-Door Fixing  
**Dimensions:** H820-870 W595 D545mm

> Installation diagram for the MBUL 100, MBUR200 & MBUF300.

# Built-In Cooling I

Model Number	MIFF501	MIFF5051F	MIFF701	MIFF7301F	MICL88	MICF88
Built-In Type	Integrated	Integrated	Integrated	Integrated	In Column	In Column
Fixing Type	Slider Fixings	Slider Fixings	Slider Fixings	Slider Fixings	Slider Fixings	Slider Fixings
Capacity Fridge (Ltr - Net)	163	163	193	193	134	-
Capacity Freezer/Icebox (Ltr - Net)	102	78	9178	69	-	99
Energy Efficiency	A+	A+	A+	A+	A+	A+
Energy Consumption (Annual)	291	298	282	286	121	195
Noise Level (dB)	39	40	39	40	41	39
Climate Class	SN/ST (10°C - 38°C)	SN/T (10°C - 43°C)	SN/ST (10°C - 38°C)	SN/T (10°C - 43°C)	T/N (16°C - 43°C)	N (16°C - 32°C)
Cooling Type	Static	Frost Free	Static	Frost Free	Static	Static
Split	50/50	50/50	70/30	70/30	-	-
Lighting Type	LED	LED	LED	LED	15W Lamp (E14)	-
Reversible Doors	Yes	Yes	Yes	Yes	Yes	Yes
Fridge Shelves	4 Glass	4 Glass Shelves	4 Glass Shelves	4 Glass Shelves	3 1/2 Glass	-
Freezer Compartments	4 Compartments	4 Compartments	3 Compartments	3 Compartments	-	4
Wine Rack	-	-	-	-	Yes	-
Antibacterial Seal	Yes	Yes	Yes	Yes	-	-
Humidity Control	-	-	-	-	-	-
Chiller Zone (0°C)	-	-	-	-	-	-
LED Flashing Alarm	-	-	-	-	-	-
Guarantee	5 Years P&L	5 Years P&L	5 Years P&L	5 Years P&L	5 Years P&L	5 Years P&L
Net Weight (kg)	60	60	57	55	29.18	36.19
Gross Weight (kg)	65	65	61	60	31.88	38.78
Dimensions Product (mm)	H1781 W540 D545	H1781 W540 D545	H1781 W540 D545	H1781 W540 D545	H875 W540 D545	H875 W540 D545
Dimensions Packed (mm)	H1874 W576 D600	H1874 W576 D600	H1874 W576 D600	H1874 W576 D600	H939 W600 D584	H939 W600 D584
EAN Number	5023790043540	5023790043571	5023790043564	5023790043571	5055862311929	5055862311936

# Built-In Cooling |

Model Number	MICL122	MICR122	MITL100	MITF300	MBUL100	MBUR200	MBUF300
Built-In Type	Integrated	Integrated	Integrated	Integrated	Built-Under	Built-Under	Built-Under
Fixing Type	Slider Fixings	Slider Fixings	Door on Door Fixings	Door-on-Door Fixings	Door-on-Door Fixings	Door-on-Door Fixings	Door-on-Door Fixings
Capacity Fridge (Ltr - Net)	204	175	300	-	128	105	-
Capacity Freezer/Icebox (Ltr - Net)	-	17	-	197	-	18	87
Energy Efficiency	A+	A+	A+	A+	A+	A+	A+
Energy Consumption (Annual)	126	209	141	283	117	183	183
Noise Level (dB)	39	42	42	41	39	39	42
Climate Class	N (16°C - 32°C)	N (16°C - 32°C)	ST/SN (16°C - 38°C)	ST/SN (16°C - 38°C)	SN/T (10°C - 43°C)	SN/T (10°C - 43°C)	SN/T (10°C - 43°C)
Cooling Type	Static	Static	Static	Frost Free	Static	Static	Static
Split	-	-	-	-	-	-	-
Lighting Type	15W Lamp (E14)	15W Lamp (E14)	LED	LED	15W Lamp (E14)	15W Lamp (E14)	-
Reversible Doors	Yes	Yes	Yes	Yes	Yes	Yes	Yes
Fridge Shelves	4 1/2 Glass	3 1/2 Glass	5 Glass	-	2 1/2 Glass	2 Glass	-
Freezer Compartments	-	4* Icebox	-	8	-	4* Icebox	3
Wine Rack	Yes	-	Yes	-	-	-	-
Antibacterial Seal	-	-	-	-	-	-	-
Humidity Control	-	-	Yes	-	-	-	-
Chiller Zone (0°C)	-	-	Yes	-	-	-	-
LED Flashing Alarm	-	-	Yes	Yes	-	-	-
Guarantee	5 Years P&L	5 Years P&L	5 Years P&L	5 Years P&L	5 Years P&L	5 Years P&L	5 Years P&L
Net Weight (kg)	37.15	37.50	53.34	58.78	30	31.5	33
Gross Weight (kg)	40.64	40.82	57.34	62.78	33	34.5	36
Dimensions Product (mm)	H1225 W540 D545	H1225 W540 D545	H1770 W540 D545	H1770 W540 D545	H820-870 W595 D545	H820-870 W595 D545	H820-870 W595 D545
Dimensions Packed (mm)	H1289 W584 D600	H1289 W584 D600	H1834 W584 D600	H1834 W584 D600	H896 W636 D575	H896 W636 D575	H896 W636 D575
EAN Number	5055862311912	5055862311943	5055862311912	5055862311918	5023790037895	5023790037396	5023790037402

# Accessories | Hot Taps



## Multiplex 3in1QB | Multiplex 3in1QC 3-In-1 Hot Tap

### Key Features:

- > Quad Spout
- > 98°C Near Boiling Filtered Water
- > Hot and Cold Water
- > Handle Safety
- > Boiler (Boil3) Included
- > 360° Spout Rotation
- > Brushed Steel or Chrome

**5** YEAR + **2** YEAR  
GUARANTEE GUARANTEE  
— Taps — — Boil3 Tank —



**Multiplex**  
 Several functions | one stream ■■■■



## Multiplex 3in1SB | Multiplex 3in1SC 3-In-1 Hot Tap

### Key Features:

- > Swan Spout
- > 98°C Near Boiling Filtered Water
- > Hot and Cold Water
- > Handle Safety
- > Boiler (Boil3) Included
- > 360° Spout Rotation
- > Brushed Steel or Chrome

**5** YEAR + **2** YEAR  
GUARANTEE GUARANTEE  
— Taps — — Boil3 Tank —



**Multiplex**  
 Several functions | one stream ■■■■

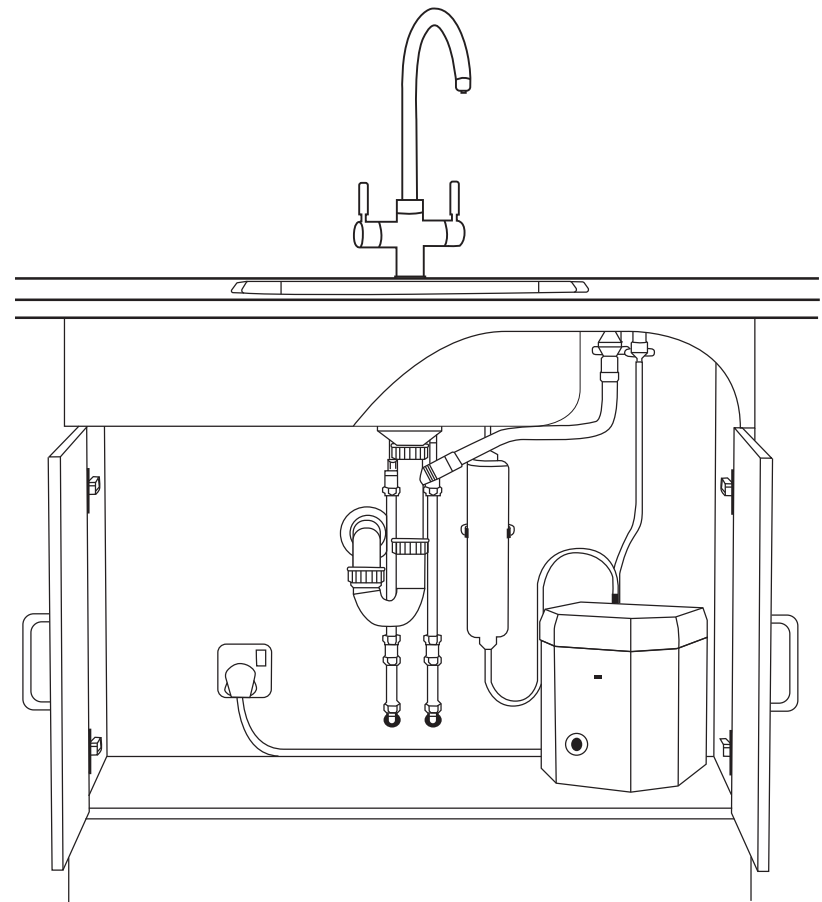

> Installation diagram for all Multiplex Taps.

# Accessories | Hot Taps



## One Stream (Chrome & Brushed) Hot Water Tap

### Key Features:

- > Swan Spout
- > 98°C Near Boiling Water
- > Innovative Twist Valve Control Feature
- > Modern Minimalism with Flair
- > Installation Kit and Filter Cartridge Inc.
- > Simple Twist Feature Delivers Filtered Water
- > Metal Construction Throughout
- > Chrome & Brushed Steel

**5**  
YEAR  
GUARANTEE  
— Tap —

**2**  
YEAR  
GUARANTEE  
— Boil3 Tank —



SWAN SPOUT



INSTANT  
HOT WATER



TANK DESCALE



2 COLOURS

## ONE STREAM HOT TAP

### Boil3

#### Boiler for Multiplex and One Stream Taps

### Key Features:

- > Descale Inlet & Removable Tank Lid
- > Filtered Water Inlet
- > 98°C Water Outlet
- > Safety Steam Vent to a Standard Dishwasher Connection
- > 2 Litre Tank
- > UK Manufactured Boiler
- > Compact Size

**2**  
YEAR  
GUARANTEE  
— Boil3 Tank —



TANK DESCALE

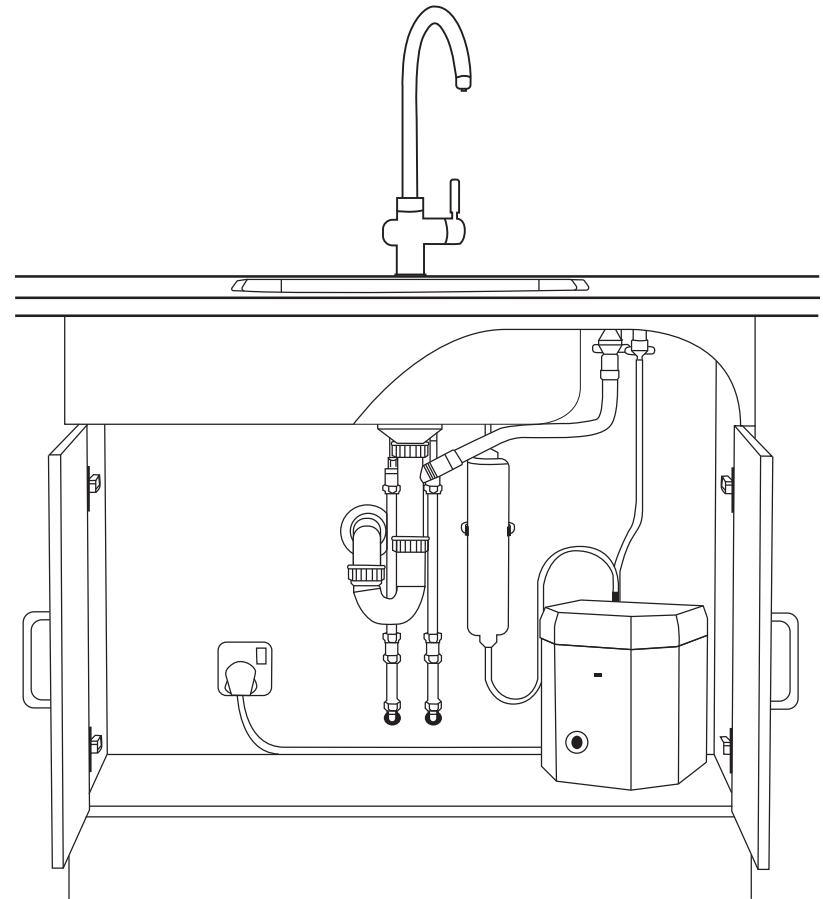

> Installation diagram for all One Stream Taps.

# Accessories | Hot Taps

Model Number	3in1QB	3in1QC	3in1SB	3in1SC
Product Type	3-In-1 Hot Tap	3-In-1 Hot Tap	3-In-1 Hot Tap	3-In-1 Hot Tap
Spout Type	Quad	Quad	Swan	Swan
Finish	Brushed	Chrome	Brushed	Chrome
Filters Included	Yes - F6M x 1	Yes - F6M x 1	Yes - F6M x 1	Yes - F6M x 1
Boiler Included	Yes - Boil3	Yes - Boil3	Yes - Boil3	Yes - Boil3
UK Fitted Plug	Yes	Yes	Yes	Yes
Waste Plumbing Attachments	Yes	Yes	Yes	Yes
Installation Kit Included (hoses & safety vent)	Yes	Yes	Yes	Yes
Guarantee - Tap	5 Year P & L	5 Year P & L	5 Year P & L	5 Year P & L
Overall Height/Projection (mm)	427	427	427	427
Exit Spout Reach (mm)	222	222	216	216
Exit Spout Height (mm)	287	287	298	298
Base Dimension (mm)	48	48	48	48
Recommended Hole Diameter (mm)	Ø 35	Ø 35	Ø 35	Ø 35
Max Surface Diameter (mm)	50	50	50	50
Spout Diameter (mm)	24	24	24	24
Spout Aerator Size	M22x1 Male	M22x1 Male	M22x1 Male	M22x1 Male
Min Cold Water Pressure (bar)	1.5	1.5	1.5	1.5
Min Hot Water Pressure (bar)	0.75	0.75	0.75	0.75
Max Domestic Hot Water Temp (°C)	46°C - 70°C	46°C - 70°C	46°C - 70°C	46°C - 70°C
Part G - Mixed Flow Rate at 3bar (ltrs/min)	12.02	12.02	12.02	12.02
Control Valve Type	1x1/2" Ceramic Disc QT,1 Single Lever 35mm	1x1/2" Ceramic Disc QT,1 Single Lever 35mm	1x1/2" Ceramic Disc QT,1 Single Lever 35mm	1x1/2" Ceramic Disc QT,1 Single Lever 35mm
Product Flow Characteristics	(H&C Boiling) Dual Flow	(H&C Boiling) Dual Flow	(H&C Boiling) Dual Flow	(H&C Boiling) Dual Flow
Aerator Type	Neoparl Aerator Honeycomb	Neoparl Aerator Honeycomb	Neoparl Aerator Honeycomb	Neoparl Aerator Honeycomb
Hot & Cold Inlet Connections	Flexi Hose	Flexi Hose	Flexi Hose	Flexi Hose
Tail Pipe Inlet/Outlet Size	-	-	-	-
Inlet Pipe Type/Length	-	-	-	-
Non Return Valves	Yes, Integral to cold inlet flexi hose only	Yes, Integral to cold inlet flexi hose only	Yes, Integral to cold inlet flexi hose only	Yes, Integral to cold inlet flexi hose only
Net Weight Tap (kg)	-	-	-	-
EAN Number	-	-	-	-

# Accessories | Hot Taps

Model Number	OneStream (Brushed)	OneStream (Chrome)	Boiler	Boil 3
Product Type	98°C Hot Tap	98°C Hot Tap	Product Type	Boiler
Spout Type	Swan	Swan	Tank Capacity (ltr)	2 Litre
Finish	Brushed	Chrome	Finish	Grey
Filters Included	Yes - F6M x 1	Yes - F6M x 1	Water Outlet Temperature	98°C
Boiler Included	Yes - Boil3	Yes - Boil3	Filtered Water Inlet	Yes
UK Fitted Plug	Yes	Yes	WRAS Approval	Pending
Waste Plumbing Attachments	Yes	Yes	Removable Tank Lid	Yes, for easy cleaning and descaling
Installation Kit Included (hoses & safety vent)	Yes	Yes	Wall Mountable	Yes
Guarantee - Tap	5 Year P & L	5 Year P & L	UK Fitted Plug	Yes
Overall Height/Projection (mm)	273	273	Country of Manufacture	United Kingdom
Exit Spout Reach (mm)	108	108	Dimensions (mm)	H257 W217 D175
Exit Spout Height (mm)	195	195	Guarantee - Boiler	2 Years P & L
Base Dimension (mm)	46	46		
Recommended Hole Diameter (mm)	Ø 35	Ø 35	<b>Filters</b>	<b>F6M - Filters</b>
Max Surface Diameter (mm)	55	55	Product Type	Filter
Spout Diameter (mm)	20	20	For Use With	Multiplex or OneStream Taps
Spout Aerator Size	M18 x 1 Mal	M18 x 1 Mal	Special Features	Chlorine Taste & Odour Reduction Inbuilt Corrosion Protection Mineral Adaption & Scale Reduction Reduces Scaling Potential of Water
Min Cold Water Pressure (bar)	-	-	Available In	Twin Packs Only
Min Hot Water Pressure (bar)	0.50/5.5	0.50/5.5	Replacement Period	6-12 Months
Max Domestic Hot Water Temp (°C)	46°C - 70°C	46°C - 70°C		
Part G - Mixed Flow Rate at 3bar (ltrs/min)	13.30	13.30		
Control Valve Type	Single lever Ceramic Cartridge, Ceramic Disk QT	Single lever Ceramic Cartridge, Ceramic Disk QT		
Product Flow Characteristics	(C&F / H) Dual Flow	(C&F / H) Dual Flow		
Aerator Type	Neoparl Aerator Honeycomb	Neoparl Aerator Honeycomb		
Hot & Cold Inlet Connections	-	-		
Tail Pipe Inlet/Outlet Size	M12 / 1/2" Male	M12 / 1/2" Male		
Inlet Pipe Type/Length	Flexi Stainless Braided Hose-260mm	Flexi Stainless Braided Hose-260mm		
Non Return Valves	Hot & Cold (Integral to Tails)	Hot & Cold (Integral to Tails)		
Net/Gross Weight Tap (kg)	3.78/6.56	3.78/6.56		
EAN Number	-	-		

# Icon Guide

---

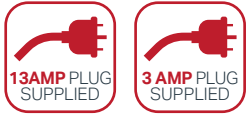

13 amp plug Included or  
3 amp Plug Included



Compatible with a 13 amp plug  
(plug not included)



Lead Supplied



Gas Cut Off



Gas Supply



Electric Supply



Trufan™ Technology



3D Hot Air System



Solid Plate Hob



Ceramic Hob



Induction Hob



Cast Iron Pan Supports



Enamel Pan Supports



2 Colour Options



3 or 4 Motor Speeds



LED Edge Lighting



Remote Controlled



Frost Free



Swan Tap Spout



Quad Tap Spout



Tank Descale



98°C Near Boiling Water



Energy Rating



# Contact Us

## Sales

T: 03333 234 473 - Option 1  
E: sales@montpellier-appliances.com

## New Accounts (apply online)

T: 03333 234 473 - Option 1  
W: apply.montpellier-appliances.com

## Customer Services

T: 03333 234 473 - Option 3  
E: customerservices@montpellier-appliances.com

## Service Enquires

T: 03333 234 473 - Option 3

## Marketing

T: 03333 234 473 - Option 6  
E: marketing@montpellier-appliances.com

Please visit [www.montpellier-appliances.com/support/](http://www.montpellier-appliances.com/support/) to download any specsheets, instruction manuals and high res images. The latest brochures can also be downloaded from our website.

## Montpellier Domestic Appliances Ltd

Unit 1  
Tewkesbury Retail Park  
Northway Lane  
Tewkesbury  
Gloucestershire  
GL20 8JU



## Get Social With Montpellier

If you would like to keep up to date with news of Montpellier please visit [www.montpellier-appliances.com](http://www.montpellier-appliances.com)

You can also keep updated by liking our Facebook page and following us on Twitter and Instagram.



Montpellier\_UK



Montpellier Domestic Appliances



montpellier\_appliances



Montpellier Domestic Appliances Ltd.

## Disclaimer

This brochure is current as from the publication date and supersedes all previous brochures for these products. Whilst Montpellier Domestic Appliances Ltd believes that all information contained within this brochure is correct at the time of going to print, no representation or warranty, express or implied, is or will be made and no responsibility or liability is or will be accepted by Montpellier Domestic Appliances Ltd in relation to accuracy or completeness of this information and any liability is expressly disclaimed. Montpellier Domestic Appliances Ltd reserves the right to modify technical data and all other information contained within this brochure without notice. All rights reserved. No part of this publication may be reproduced in any form without the prior written permission of Montpellier Domestic Appliances Ltd.

This brochure should not be regarded as an infallible guide nor as an offer of sale for a particular product. Due to variations in the reproduction process, colours of actual products may vary slightly from those depicted. We recommend you view the Montpellier Domestic Appliances in person to confirm specifications and colours are to your satisfaction.

Valid from 16th July 2018.

# Notes



Lined writing area consisting of multiple horizontal lines.

# Notes

---

---

---

---

---

---

---

---

---

---

---

---

---

---

---

---

---

---

---

---

---

---

---



**BUILT-IN  
BRILLIANCE.**  
AS STYLISH BEHIND  
THE DOOR AS IN FRONT.

**Montpellier**

T: 03333 234 473 | E: [sales@montpellier-appliances.com](mailto:sales@montpellier-appliances.com) | [www.montpellier-appliances.com](http://www.montpellier-appliances.com)

© Copyright of Montpellier Domestic Appliances Limited 2018. All rights reserved. E&OE.